

Erfahrung – Service – Qualität
Experience – Service – Quality



... seit über 40 Jahren stehen wir für Kontinuität
... for more than 40 years we have stood for continuity



Erfahrung – Service – Qualität
Experience – Service – Quality



WELCOME to FAS

... seit über 40 Jahren stehen wir für Kontinuität

... for more than 40 years we have stood for continuity

HEADQUARTER IN SALZGITTER

Peiner Str. 217



www.fas.de

HEADQUARTER IN SALZGITTER

Peiner Str. 217



- ▶ 5 manufacturing halls
- ▶ 1000 m² storage area
- ▶ 1,2 ha total area
- ▶ Approx. 200 employees



MISSION AND VISION



- “It is our mission to encourage the safe handling of LPG as an energy source by delivering the complete equipment.”
- “We set the ambitious goal to become the leading company for LPG equipment!”



MISSION AND VISION

▶ “According to the motto
“A new country every year!”,
we seek to further expand our
international business contacts and
to develop new markets worldwide.
Today, FAS is represented in
over 50 countries with their own
offices and partners.”



Lutz Jeremias (Managing Director)

WORKSHOP

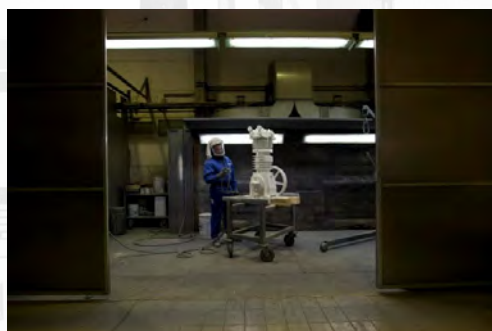

▶ Insight into the various FAS workshop areas

THE FAS PRODUCT PORTFOLIO



Our complete range of
LPG-EQUIPMENT

for

- Storage
- Transportation
- Measuring
- and supply of LPG

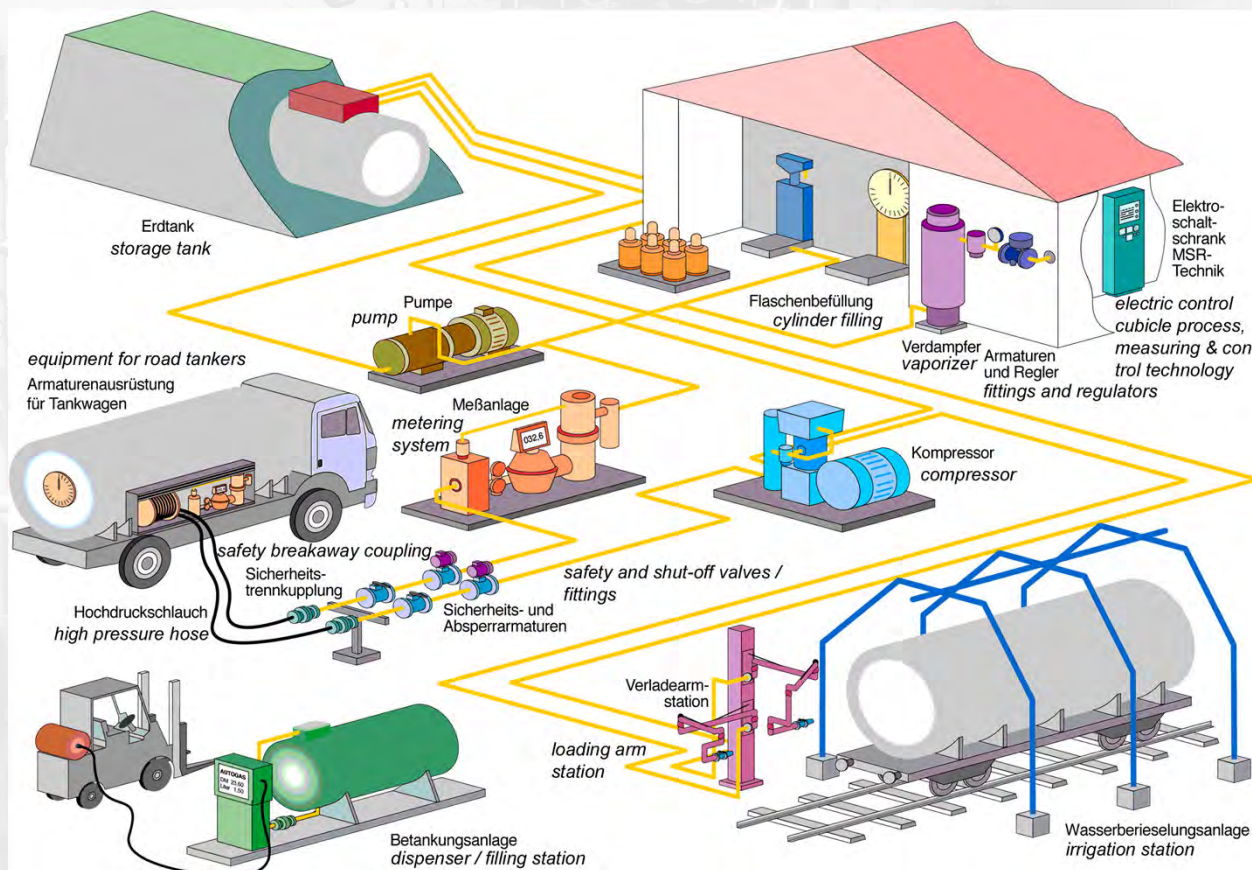

WORKSHOP



➤ Production of Vaporizers

FAS Product Portfolio: Vaporizers
Dry-type Vaporizer, Type FAS 2000



PLUG-IN VERSION READY FOR CONNECTION !

➤ **Capacity 15 kg/h - 40 kg/h, Voltage 230 V, 50-60 Hz**

www.fas.de

FAS Product Portfolio: Vaporizers
Dry-type Vaporizer, Type FAS 2000

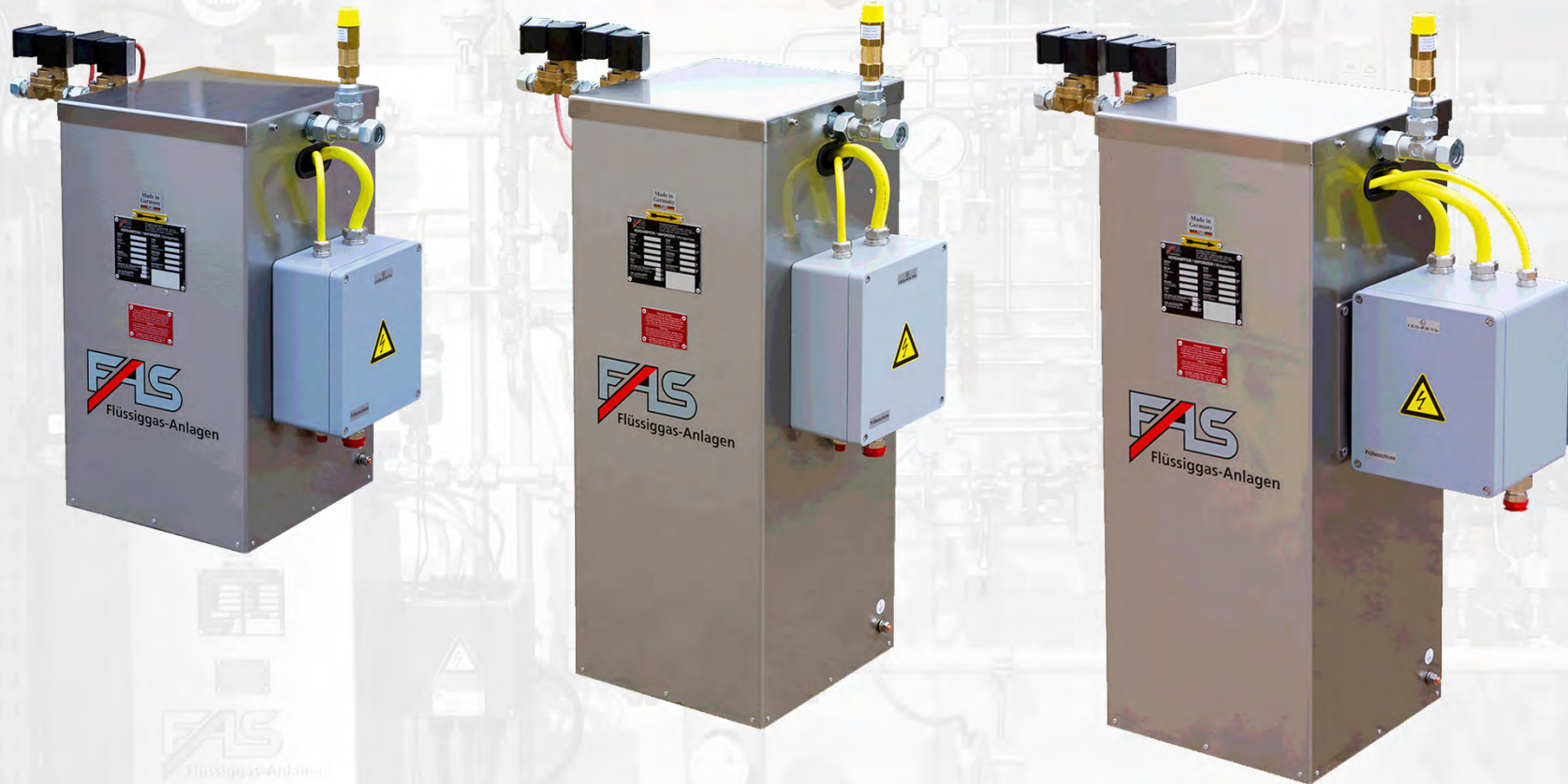

Capacity 60 kg/h to 170 kg/h, Voltage 400 V, 50 Hz

www.fas.de

FAS Product Portfolio: Vaporizers
Cabinet Construction with Single Vaporizer, Type FAS 2000



▶ **Capacity 15 kg/h to 170 kg/h**

www.fas.de

FAS Product Portfolio: Vaporizers
Cabinet Construction with Multiple Vaporizer, Type FAS 2000

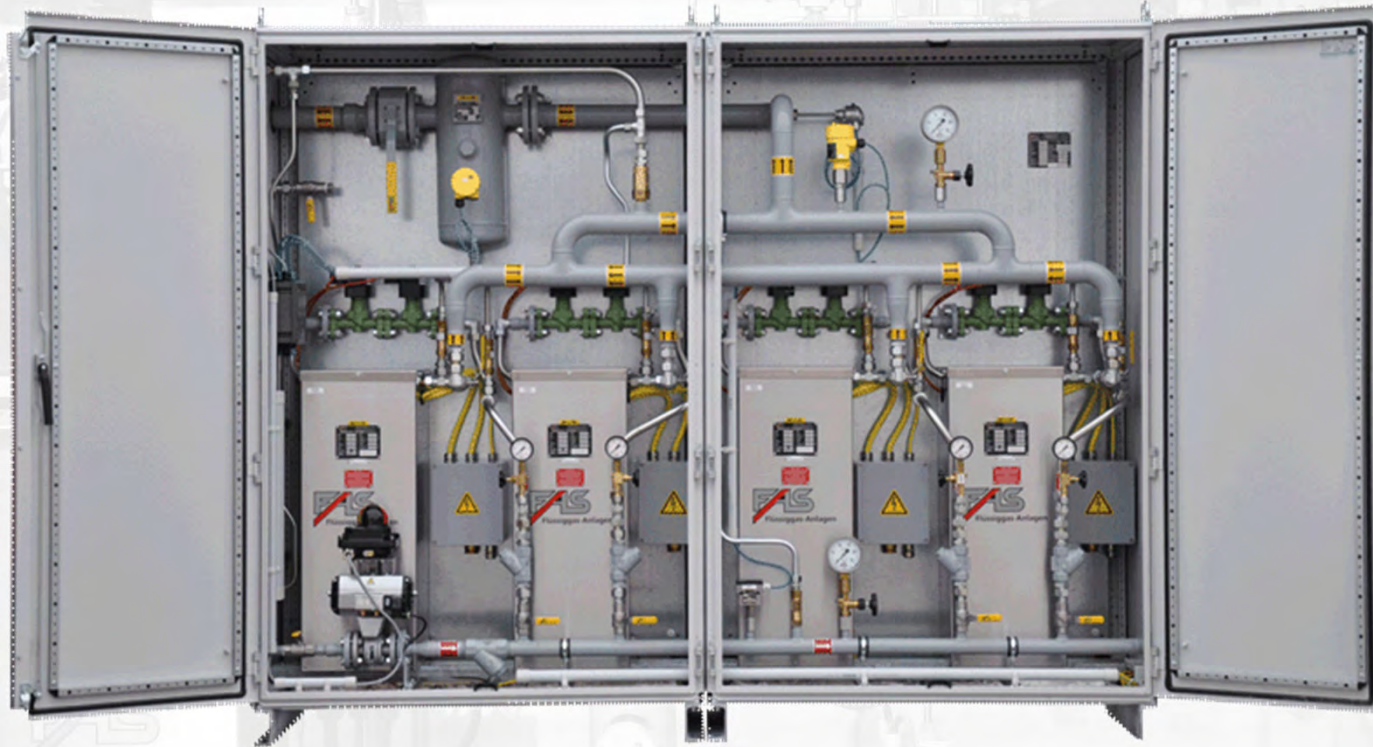

▶ **Capacity up to 620 kg/h (4 x 170 kg/h)**

www.fas.de

FAS Product Portfolio: Vaporizers
Vaporizer Unit, Type FAS 2000, Cabinet Construction with Storage Tank



➤ **Also available as FAS skid unit**

www.fas.de

FAS Product Portfolio: Vaporizers
Industrial Vaporizer, Type FAS 2000i with vaporizer control



➤ **Capacity 32 kg/h, 60 kg/h, 100 kg/h, up to 170 kg/h**

www.fas.de

FAS Product Portfolio: Vaporizer
Vaporizer Unit in Container, Capacity 7000 kg/h



FAS Product Portfolio: Vaporizers
Hot Water Vaporizer Unit in Cabinet, Type FAS 3000



▶ **Capacity up to 20.000 kg/h**

www.fas.de

**FAS Product Portfolio: SNG-Systems
Propane-Air-Mixing Units**

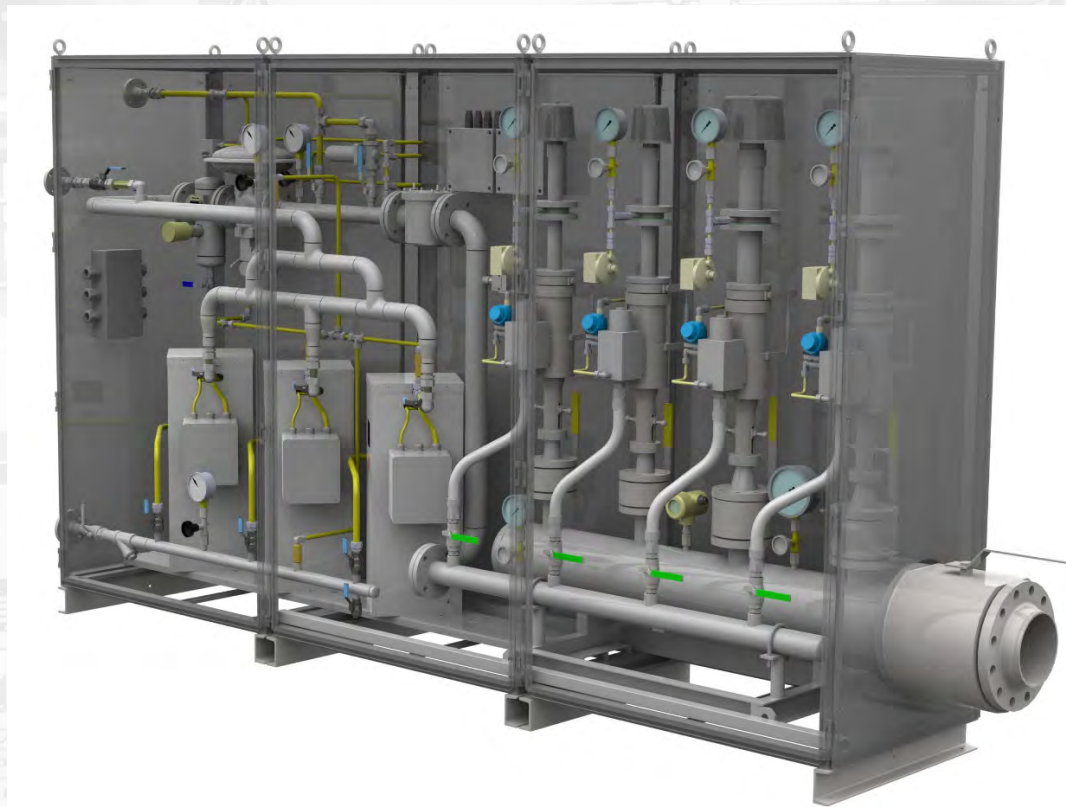

FAS Product Portfolio: SNG-Systems
Propane-Air-Mixing Unit, Type FAS 4000 LP (Low Pressure)

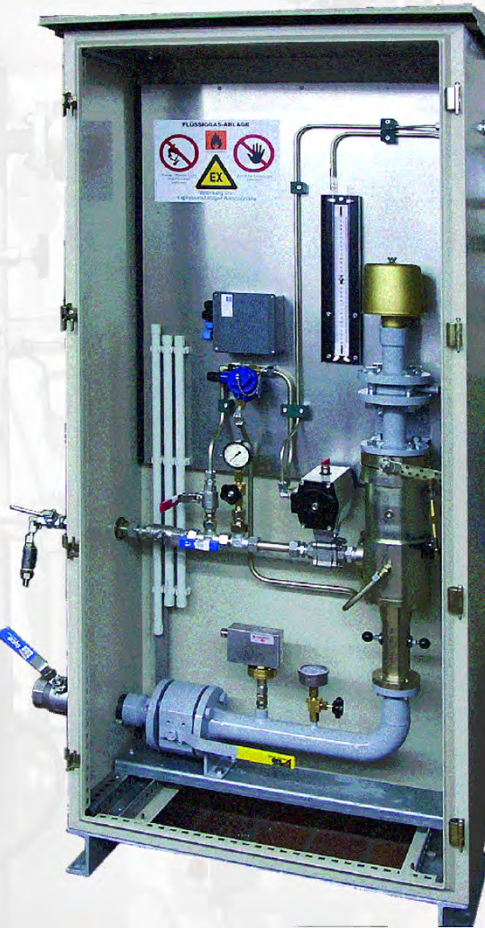

www.fas.de

FAS Product Portfolio: SNG-Systems
Propane-Air-Mixing Unit, Type FAS 4000 LP (Low Pressure)



FAS Product Portfolio: SNG-Systems
Vaporizer Unit with Mixing System in Cabinet Construction



FAS Product Portfolio: SNG-Systems
Propane-Air-Mixing Unit – Type FAS 4000 HP (High Pressure)





FAS Product Portfolio: SNG-Systems
Propane-Air-Mixing Unit – Type FAS 4000 HP (High Pressure)



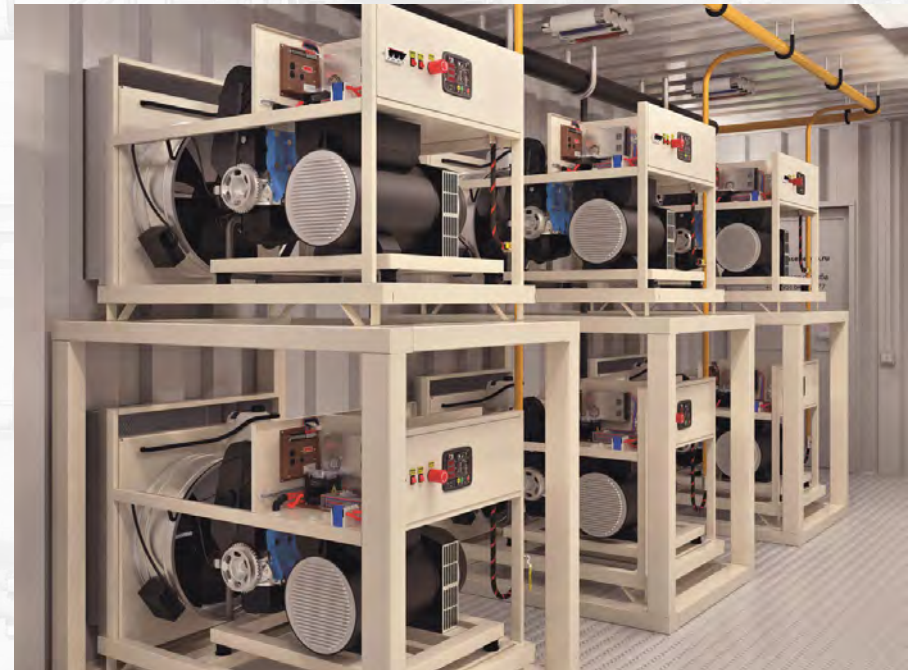
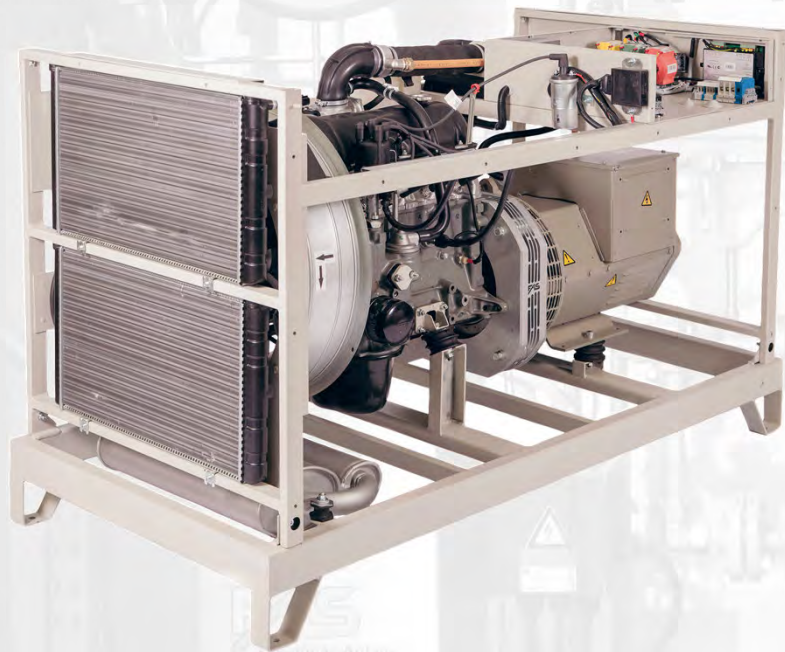

FAS Product Portfolio: Generators
Water-Cooled NG and LPG Generator





FAS Product Portfolio: Generators
Water-Cooled NG and LPG Generator

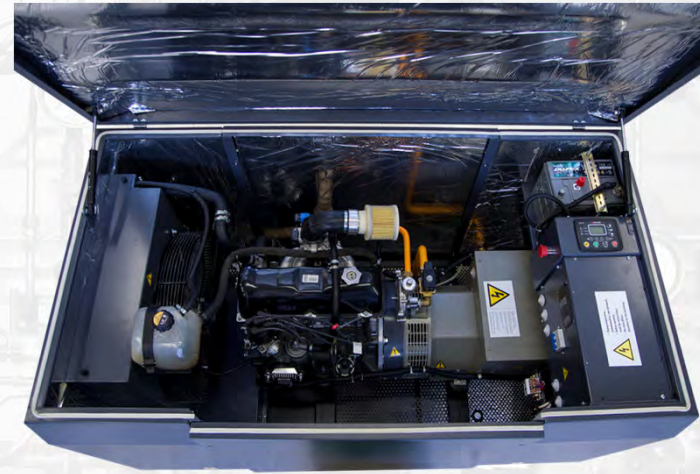

**New Version
with CE-approval**

www.fas.de

FAS Product Portfolio: Terminal Equipment
LPG Terminal



FAS Product Portfolio: Terminal Equipment "Turn-Key" Projects

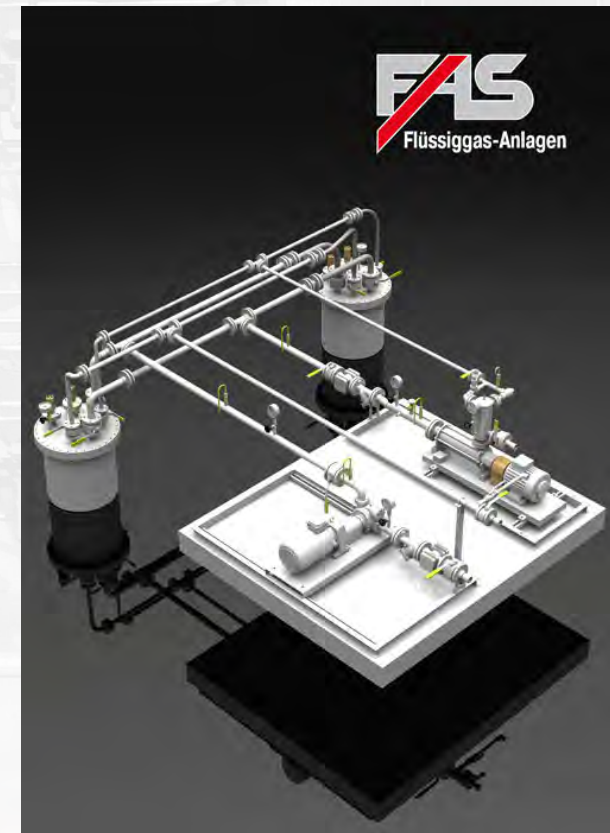
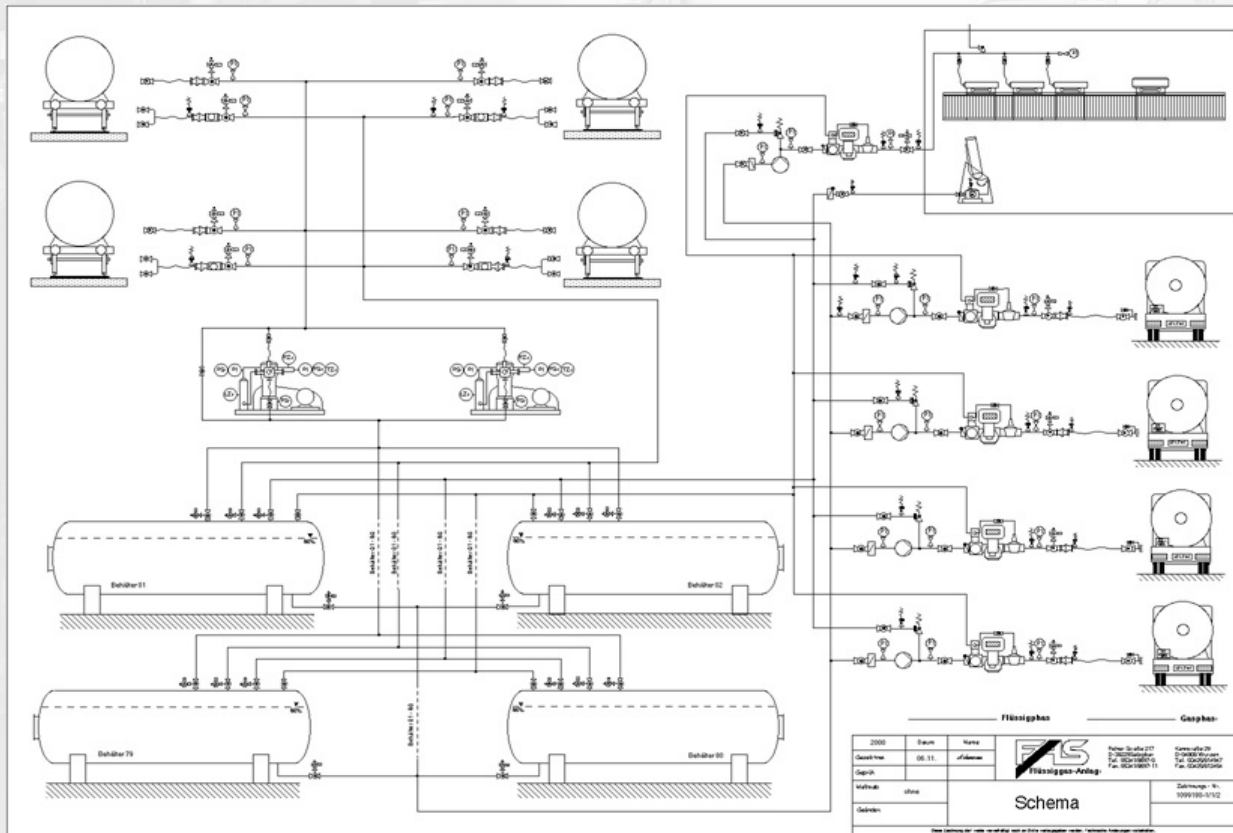

FAS Product Portfolio: Pump Units
Side Channel Pump Unit

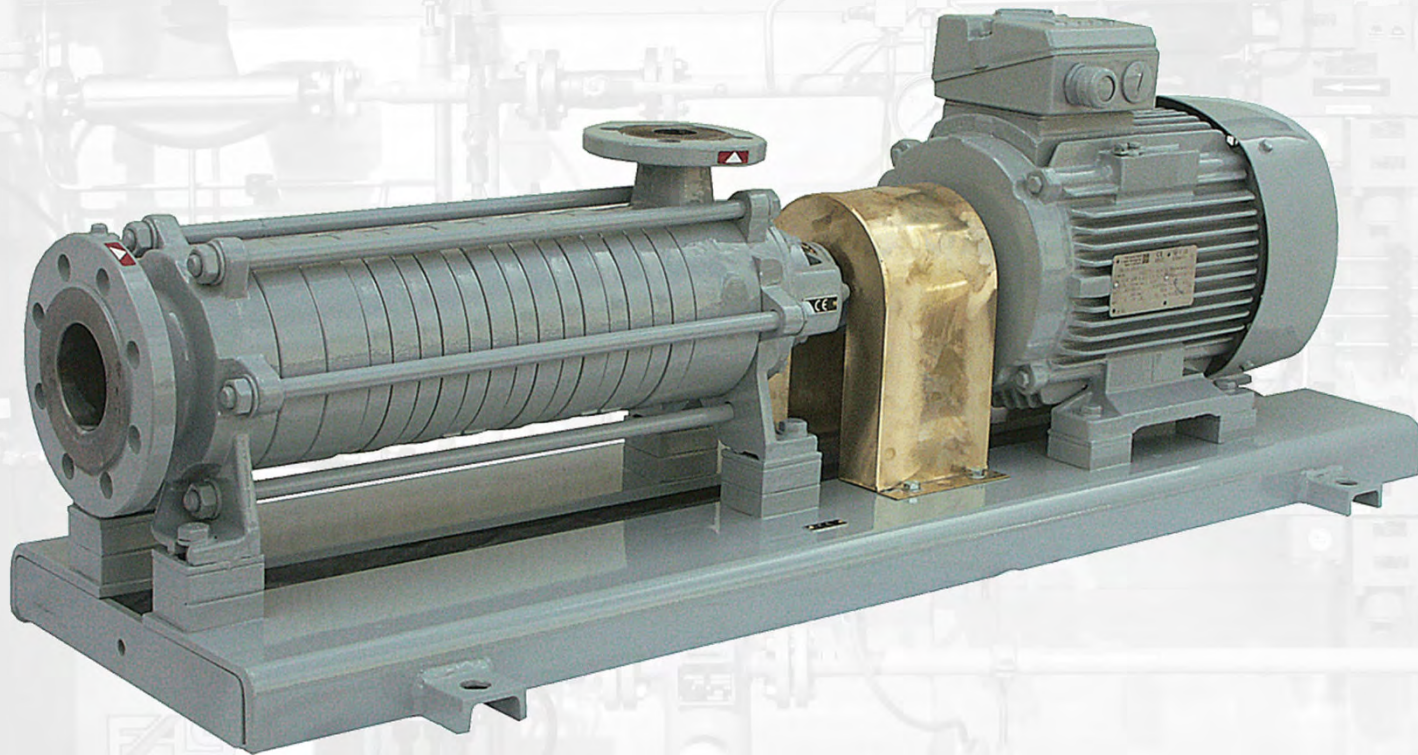



FAS Product Portfolio: Pump Units
High Performance Pump Unit, Type FAS NZ (up to 170 m³/h)

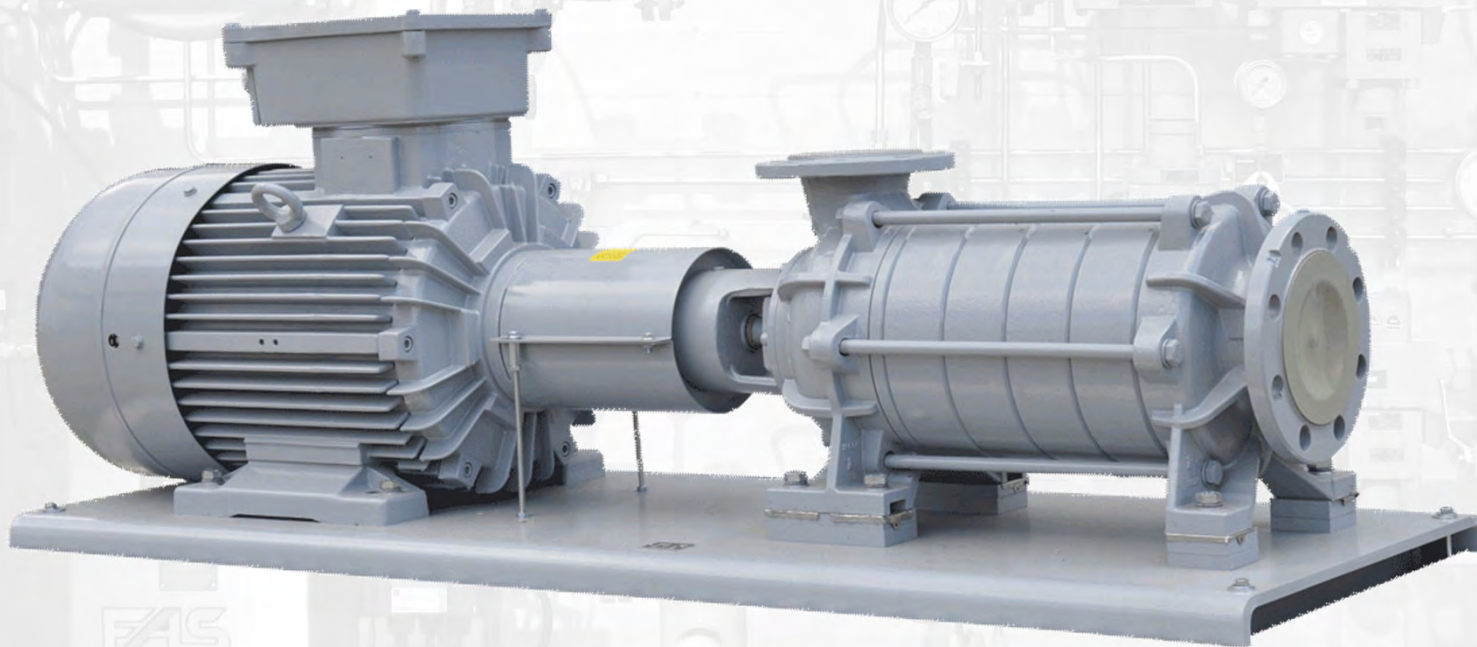

FAS Product Portfolio: Pump Units
Pumping Systems with pump type FAS NZ

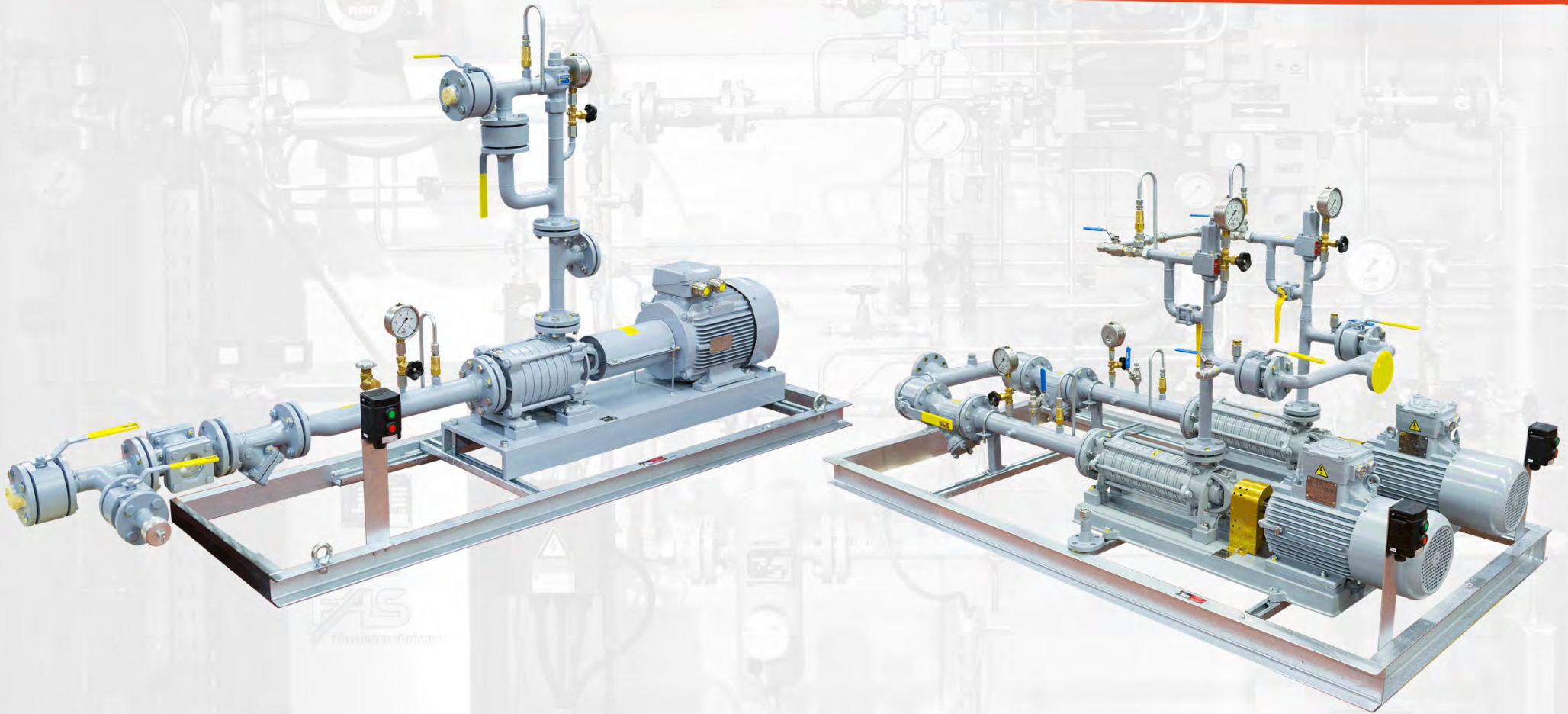

FAS Product Portfolio: Pump Units
Fully Equipped Centrifugal Pump Units





FAS Product Portfolio: Terminal Equipment
Pump Installation





FAS Product Portfolio: Pump Units
Positive Displacement Sliding Vane Pumps

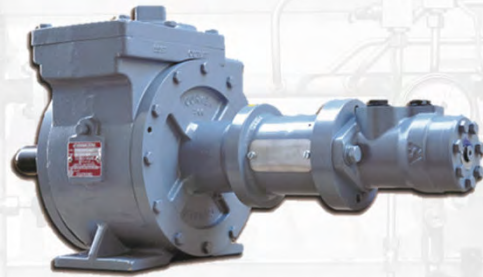

▶ **Pump unit Z3500 with hydraulic drive**

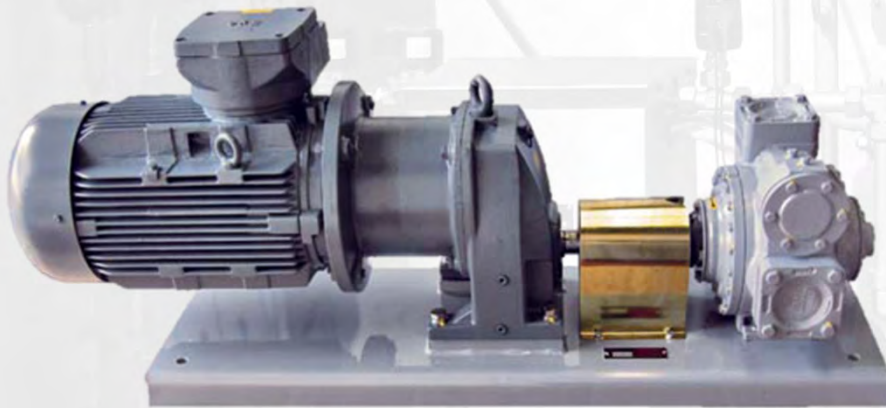

▶ **Pump unit Z2000 with gear motor**

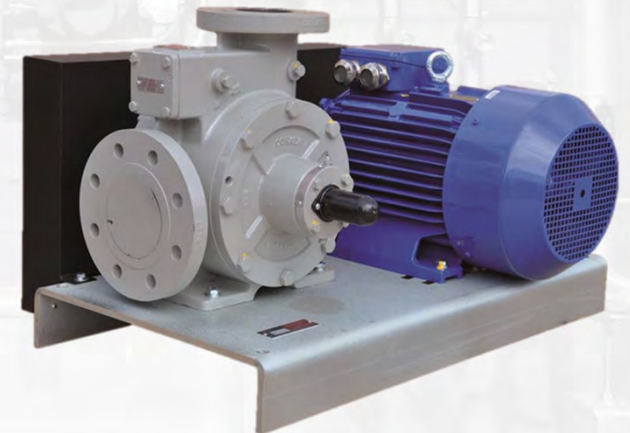

▶ **Pump unit Z4500 with V-belt drive**



**FAS Product Portfolio:
Pump and Compressor Installation**



FAS Product Portfolio: Compressor Units
Special execution on customer request



FAS Product Portfolio: Compressor Units
Special execution on customer request

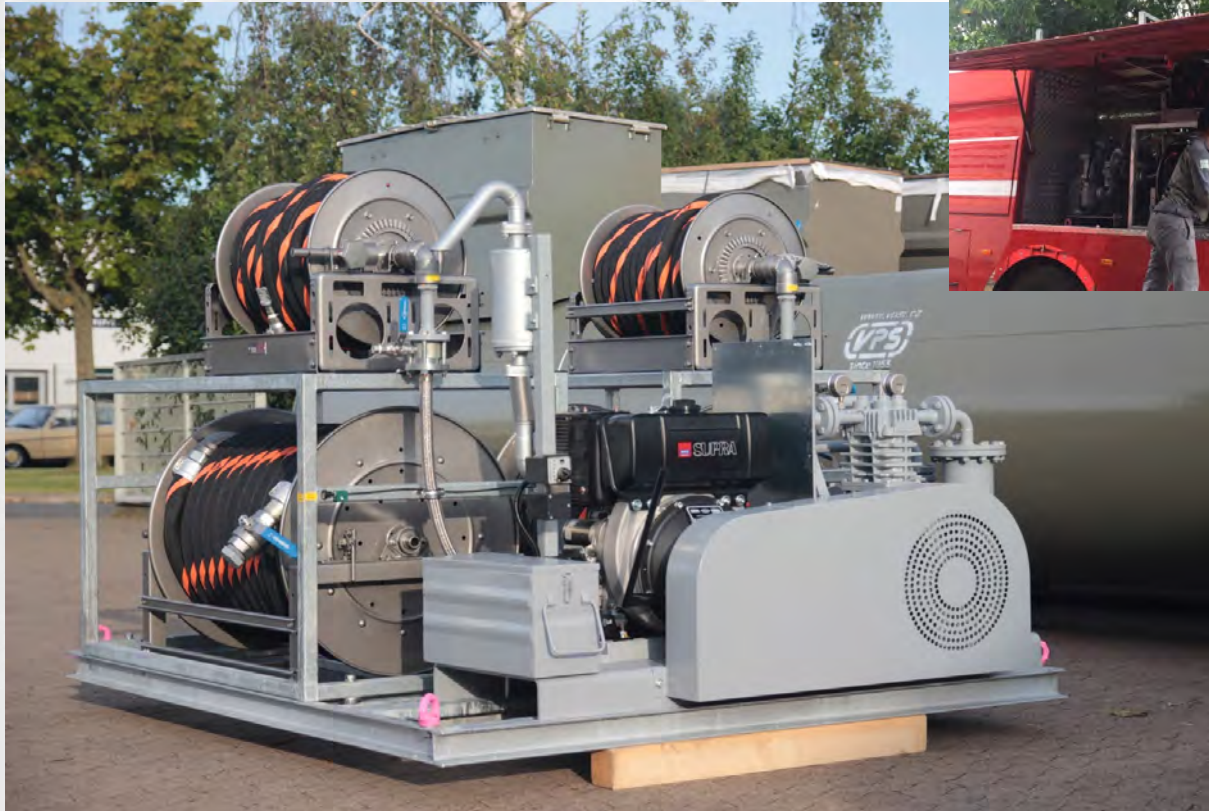

FAS Product Portfolio: Pump and Compressor System
Container version on customer request



FAS Product Portfolio: Compressor Units
Horizontal Compressors up to a Capacity of 400 m³/h



FAS Product Portfolio: Compressor Units
Mobile Compressor Unit

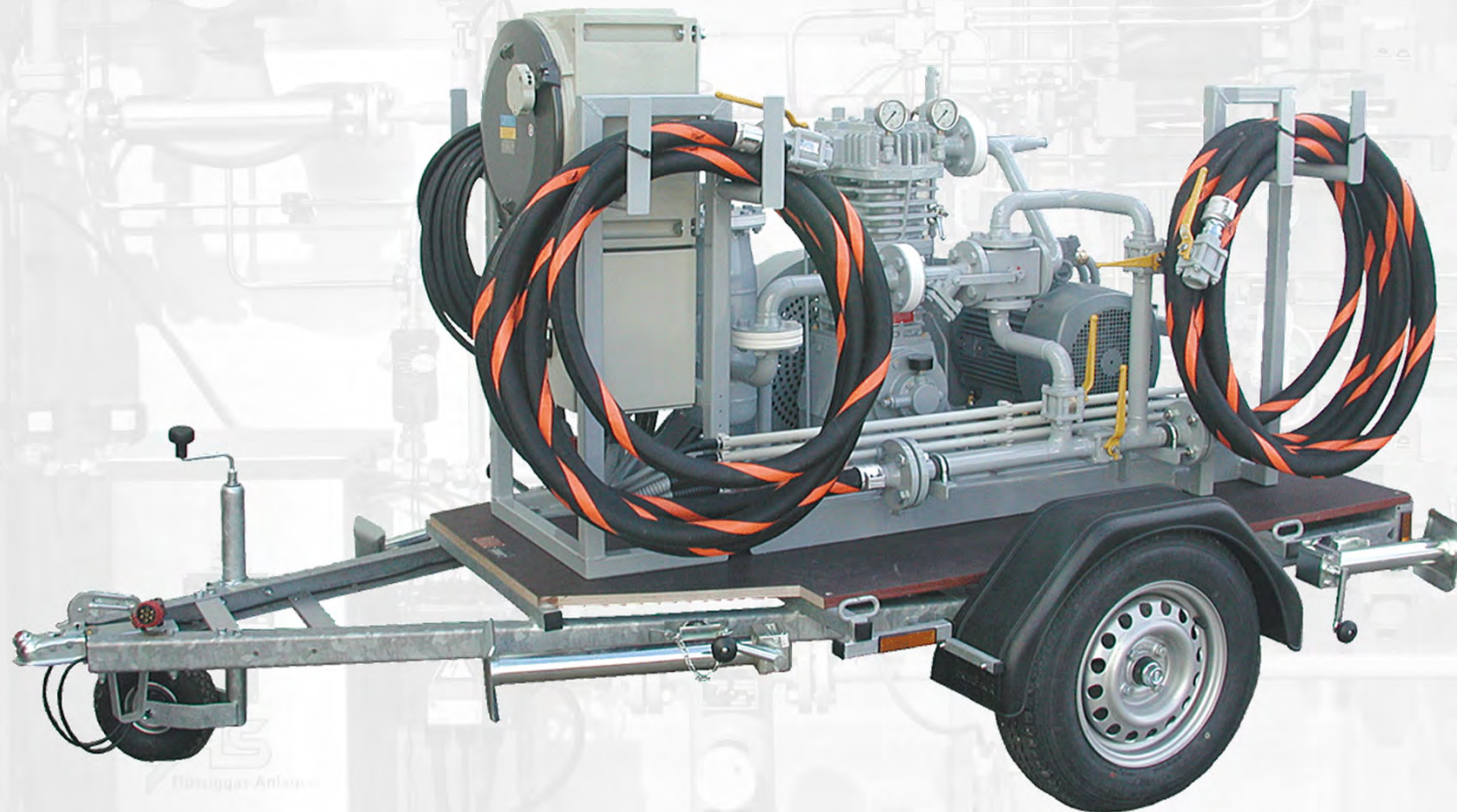

www.fas.de

FAS Product Portfolio: Compressor Units
Mobile Compressor Unit



www.fas.de

FAS Product Portfolio: Loading Arm Station

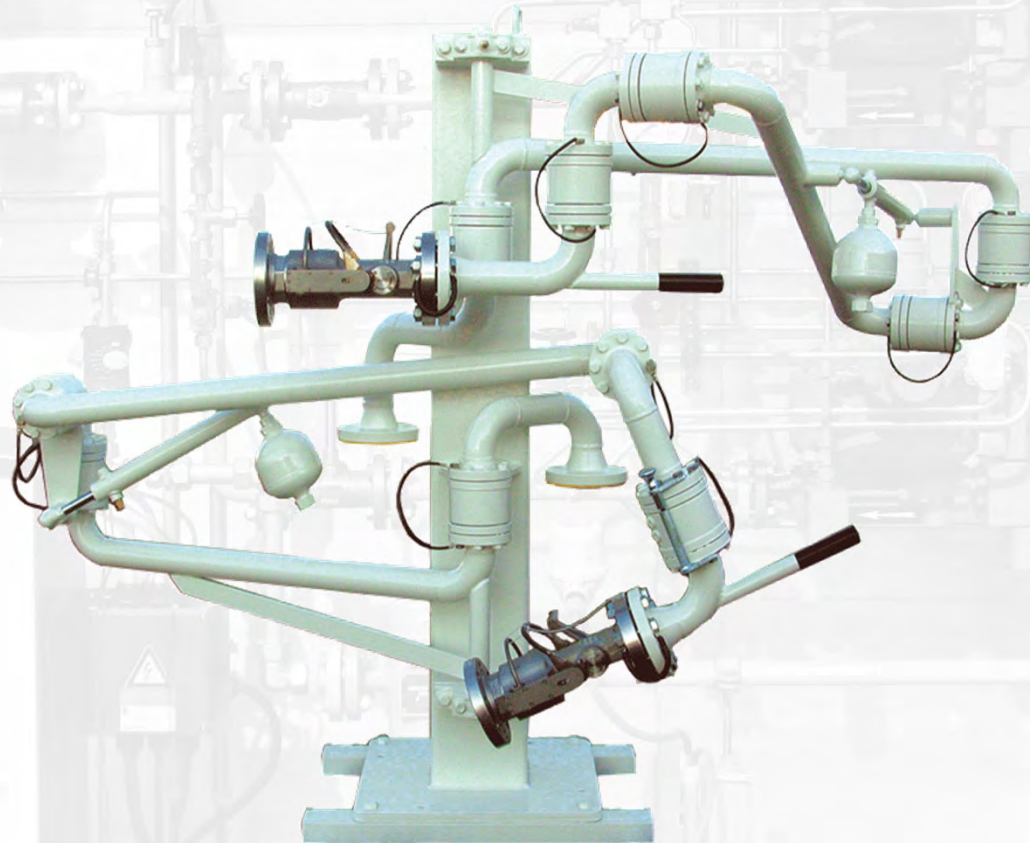

www.fas.de

FAS Product Portfolio: Loading Arm Stations



FAS Product Portfolio: Loading Arms
Loading and Unloading Plant



FAS Product Portfolio: Road Tanker Equipment
Complete Equipment Kit for Road Tankers



www.fas.de
www.fas-engineering.de



FAS Product Portfolio: Road Tanker Equipment
Complete Equipment Kit for Road Tankers



www.fas.de
www.fas-engineering.de





FAS Product Portfolio: Road Tanker Equipment
Pump Type NZ-STW

FAS
Flüssiggas-Anlagen

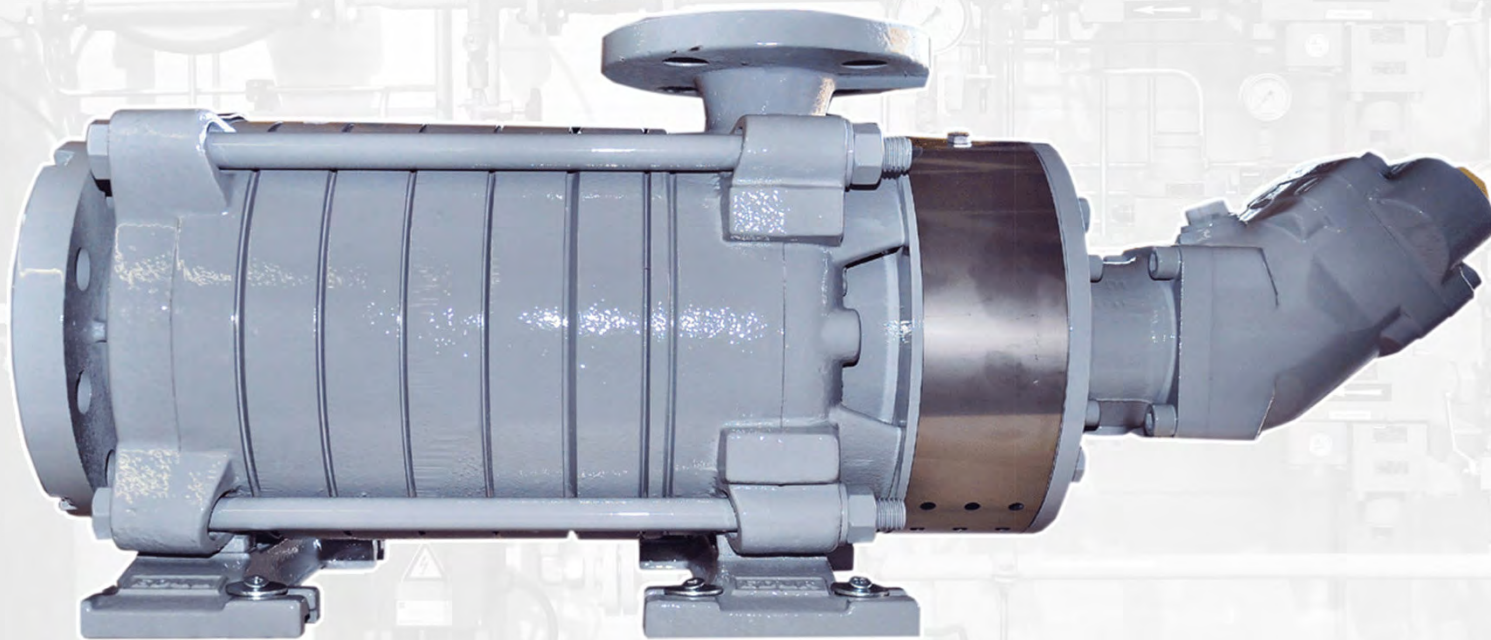

www.fas.de
www.fas-engineering.de

FAS
modern industrial solutions

FAS Product Portfolio: Road Tanker Equipment
Measuring Unit Type FAS-LPG-Control MID 400

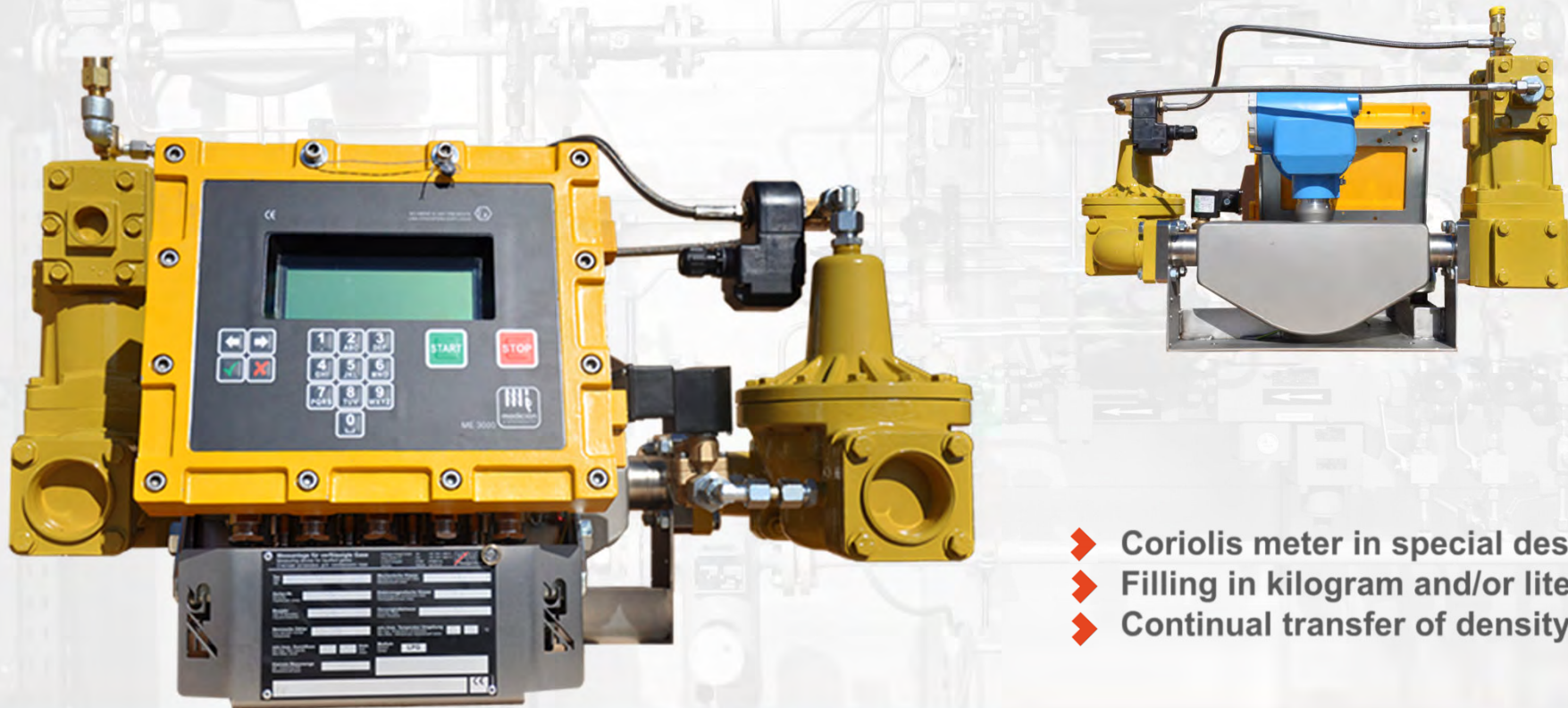

- ◆ Coriolis meter in special design
- ◆ Filling in kilogram and/or liter
- ◆ Continual transfer of density data

www.fas.de
www.fas-engineering.de

FAS
modern industrial solutions

FAS Product Portfolio: Road Tanker Equipment
Measuring Unit Type FAS-LPG-Control MID 400-Tex



NEW !!!

- ◆ For LPG, petroleum and other stationary applications
- ◆ Capacity from 20 l/min to 3000 l/min
- ◆ Full range of data transfer options
- ◆ Option: economy version as PD meter with mechanical register

www.fas.de
www.fas-engineering.de

FAS
modern industrial solutions

FAS Product Portfolio: Road Tanker Equipment
Hose Reel Type VIP40

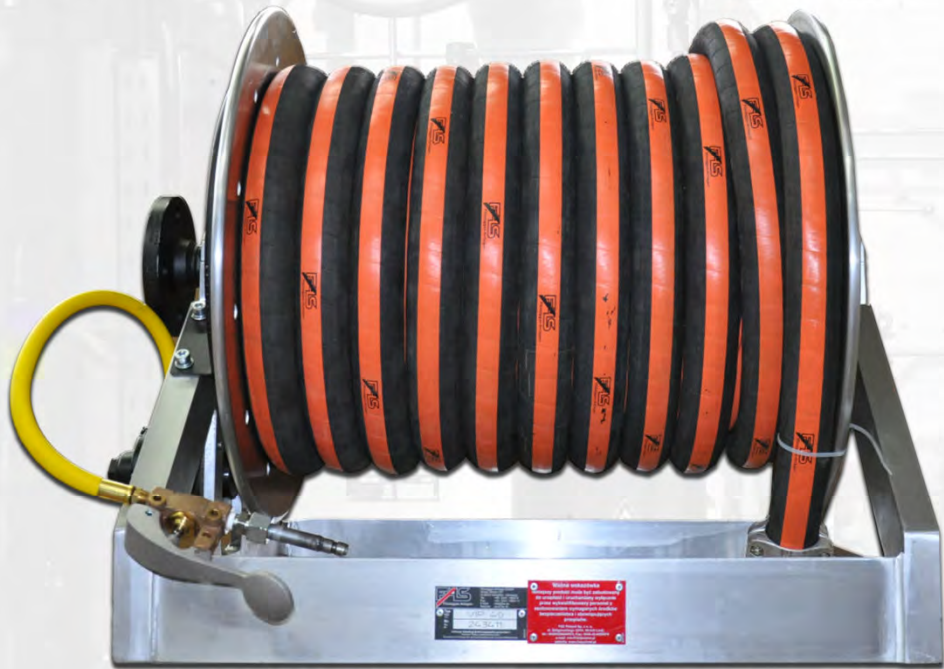

- ◆ Aluminium lightweight construction
- ◆ Corrosion-free
- ◆ Robust and compact design by internally installed swivel joint

www.fas.de
www.fas-engineering.de

FAS
modern industrial solutions

FAS Product Portfolio: Road Tanker Equipment
Measuring Station MID400 and Hose Reel Type VIP40 installed

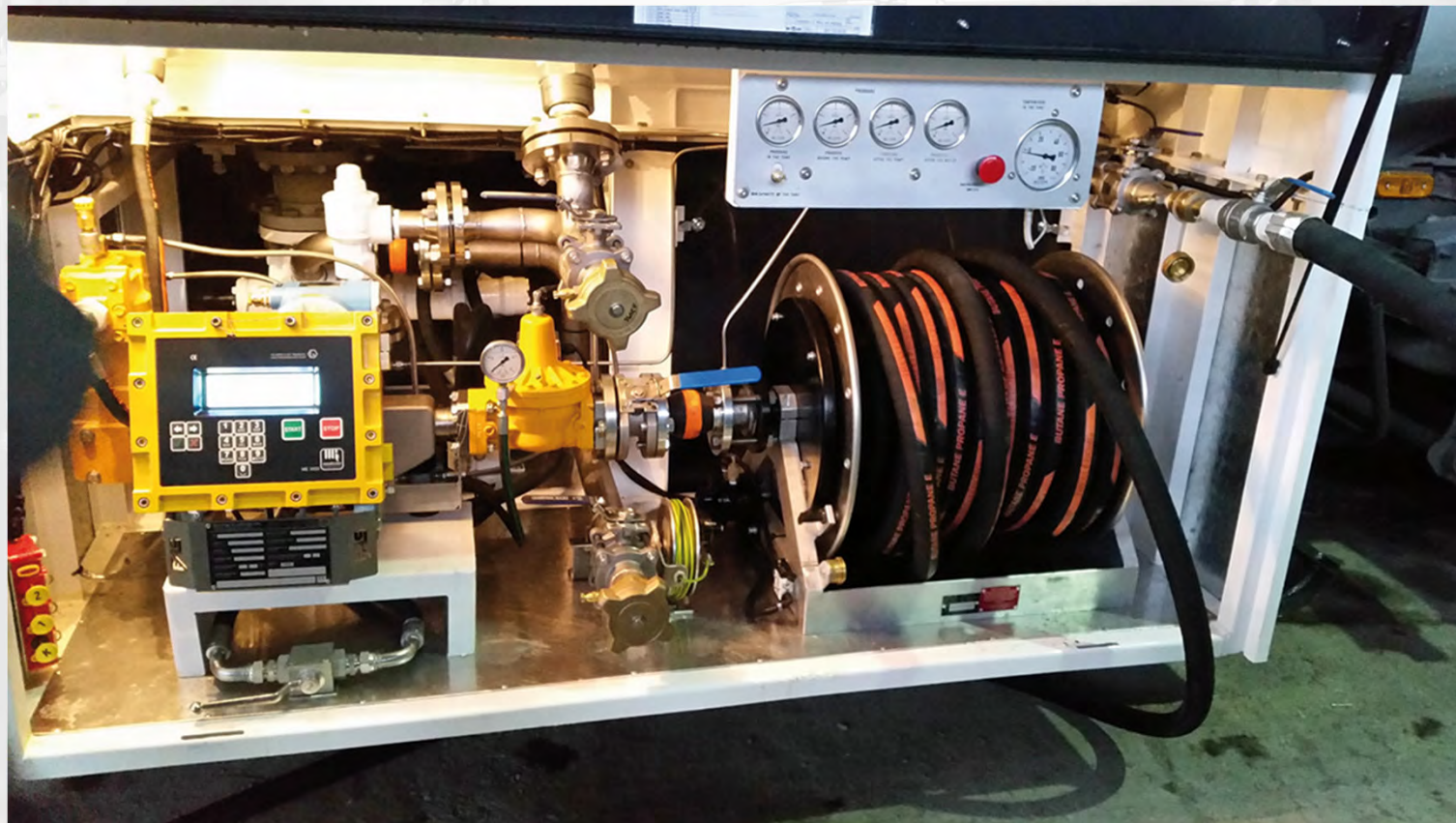

www.fas.de
www.fas-engineering.de



FAS Product Portfolio: Road Tanker Equipment
Measuring Station Type MA7-TE550 Truck III



➤ **Electronic Data Collection LCR-TE550**

FAS Product Portfolio: Measuring Station
Type MA7-TE550 Truck III – Execution on Customer Request



FAS Product Portfolio: Measuring Systems
Calibration Station



WORKSHOP



▶ Production of Dispensers

FAS Product Portfolio: Autogas Dispensers
Autogas Dispensers, type FAS-120



www.fas.de

FAS Product Portfolio: Autogas Dispensers
Autogas Dispensers, Type FAS-130, not suitable for calibration



FAS Product Portfolio: Autogas Dispensers
Autogas Dispenser, Type FAS-430, not suitable for calibration





FAS Product Portfolio: Autogas Dispensers
Autogas Dispensers, Type FAS-220 / FAS-230 / FAS-240



www.fas.de

FAS Product Portfolio: Autogas Dispensers
Autogas Dispenser Type FAS-230 „High Mast“



www.fas.de

FAS Product Portfolio: Autogas Dispensers Autogas Management System



Receipt Printer

Datatransfer



Evaluation

FAS Product Portfolio: Autogas Dispensers
Electronic Autogas Dispensers, Type FAS-420 (for Credit Cards)



FAS Product Portfolio: Autogas Dispensers
Electronic LPG Dispenser, Type FAS-120 (for Road Tankers and Busses)



**Flow rate
up to 130 l/min**



FAS Product Portfolio: Autogas Dispensers
Different Versions of LPG Dispensers in FAS Workshop



FAS Product Portfolio: LPG Filling Stations for Internal Use
Compact Filling Station with Dispenser Type FAS-130



www.fas.de

FAS Product Portfolio: LPG Filling Stations for Internal Use
Compact Filling Station with Dispenser FAS-130 with Mechanical Counter



www.fas.de

FAS Product Portfolio: LPG Filling Stations for Internal Use
Compact Filling Station with Dispensing Device



www.fas.de

FAS Product Portfolio: LPG Filling Stations for Internal Use
Fork Lift Truck Filling



FAS Product Portfolio: LPG Filling Stations
- For Car and Road Tankers with High Capacity Dispenser Type FAS-120



**Flow rate up to
130 l/min**

FAS Product Portfolio: LPG Filling Stations
Road Tanker Filling Station with High Capacity Dispenser type FAS-230



FAS Product Portfolio: LPG Filling Stations
Road Tanker Filling Station: Embedding of Tank



**FAS Product Portfolio: LPG Filling Stations
Autogas Filling Station: Embedding of Tank**



FAS Product Portfolio: LPG Filling Stations
Autogas Filling Station: Embedding of Tank



FAS Product Portfolio: LPG Filling Stations
Thermoflex Flexible Pipework for LPG Filling Stations and Industrial Application



FAS Product Portfolio: LPG Filling Stations
Compact Filling Station with Dispenser Type FAS-420 & Protection Roof



www.fas.de

FAS Product Portfolio: LPG Filling Stations
Compact Filling Station with Dispenser Type FAS-120 & Protection Roof



FAS Product Portfolio: Autogas Filling Stations
Domepit of Underground Tank

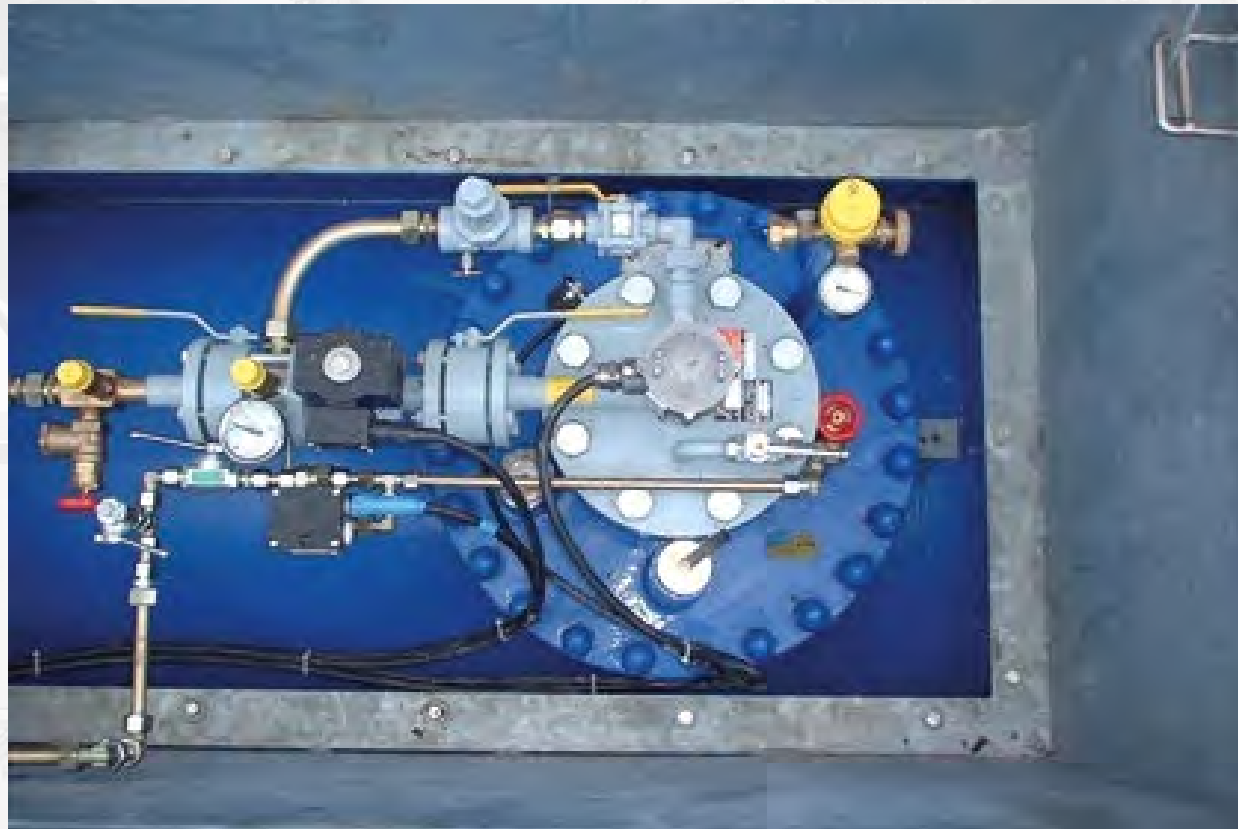

FAS Product Portfolio: Autogas Dispensers
Autogas Filling Station with Dispenser Type FAS-230



FAS Product Portfolio: Autogas Dispensers
Autogas Filling Station with Dispenser Type FAS-230



www.fas.de

FAS Product Portfolio: Autogas Dispensers
Autogas Filling Station with Dispenser Type FAS-230



FAS Product Portfolio: Autogas Dispensers
Autogas Filling Station with Dispenser Type FAS-230 „High-Mast“



FAS Product Portfolio: Autogas Dispensers
Autogas Filling Station with Dispenser Type FAS-230 „High-Mast“



FAS Product Portfolio: Autogas Dispensers
Autogas Filling Station with Dispenser Type FAS-230 „High-Mast“



FAS Product Portfolio: Autogas Dispensers
Autogas Filling Station with Dispenser Type FAS-230 „High-Mast“



FAS Product Portfolio: Autogas Dispensers
*Autogas Filling Station with Dispenser Type 230 „High Mast“ and Additional
Dispensing Point for Industrial Distribution*



▶ Pumping System

▶ Measuring System

LPG, LNG, CNG Industrial Management



Your partner for reliable LNG / CNG solutions

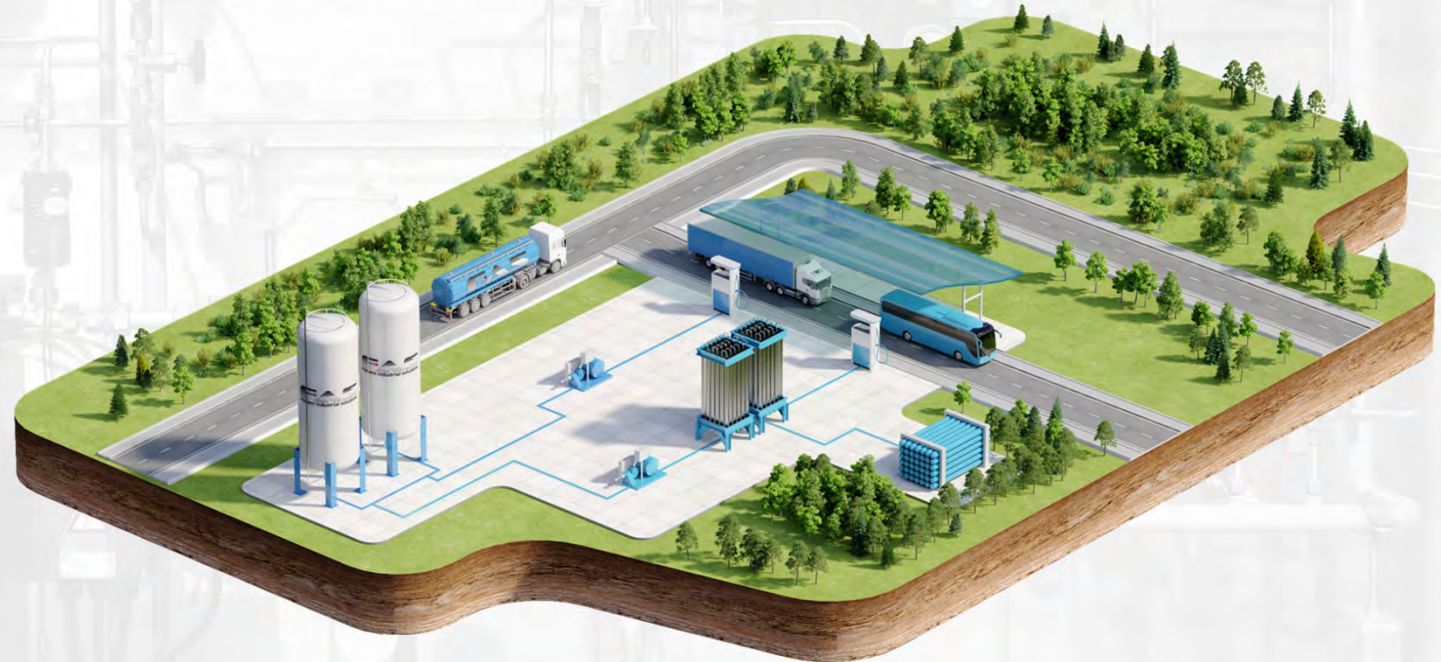

www.fas.de
www.fas-engineering.de



LPG, LNG, CNG Industrial Management



Overview of our services

- Suitability test of land plot
- Planning – engineering - documentation
- Introduction and monitoring of construction phase
- Supply, installation and commissioning of the complete plant
- Service and maintenance as an option



www.fas.de
www.fas-engineering.de



Suitability test of land plot:

- Determination of safety relevant distances
- Preparation of required 3D-drawings
- Result report of local circumstances
- Final assessment of suitability of land plot



LPG, LNG, CNG Industrial Management



Planning – Engineering - Documentation of your LNG / CNG plant respectively filling station:

- Planning of plant according to customer request
- Preparation of all required technical documents
- Preparation of documentation for the application for approval



www.fas.de
www.fas-engineering.de



LPG, LNG, CNG Industrial Management

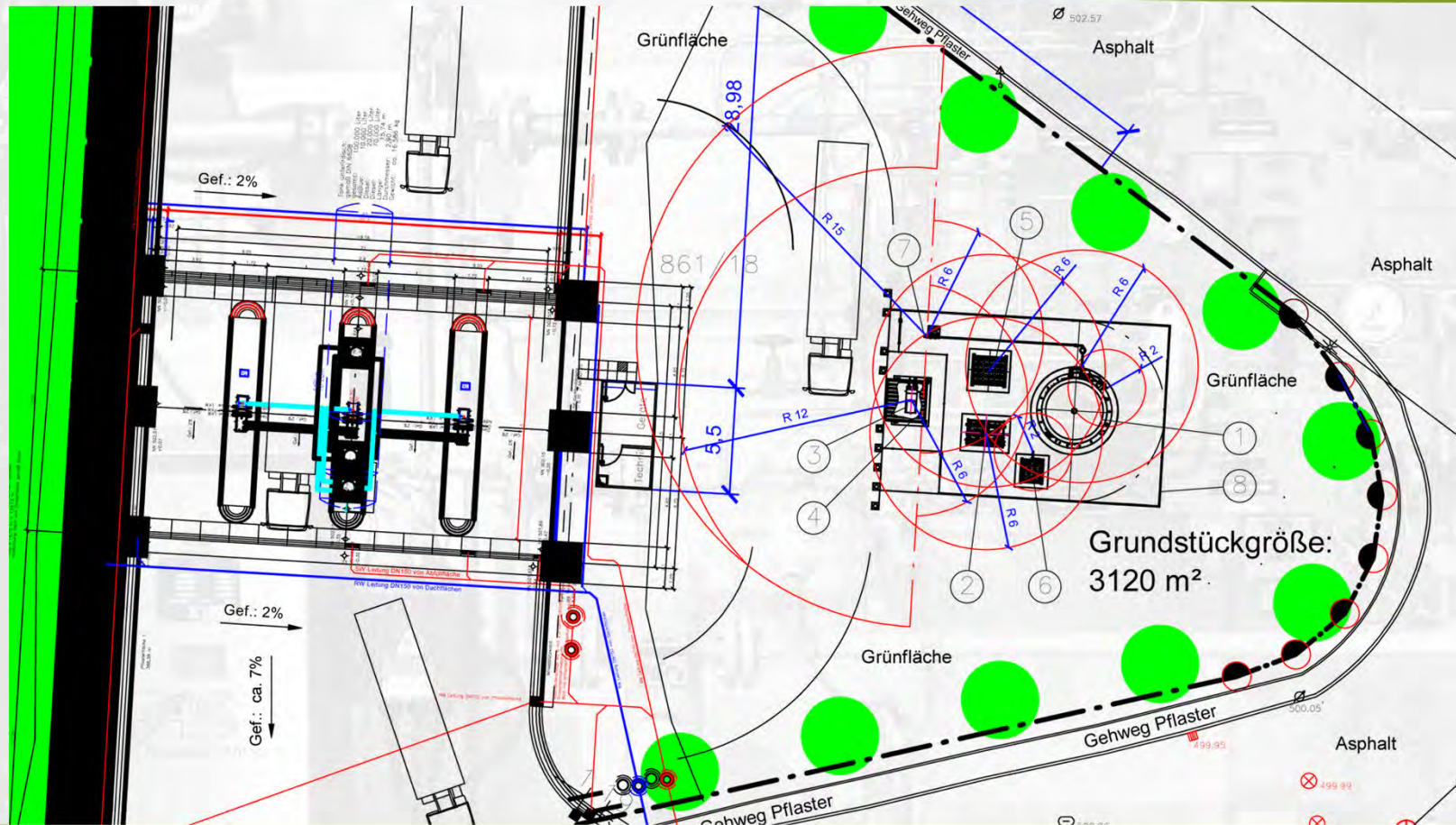

Standard LNG Plants – Example Systems

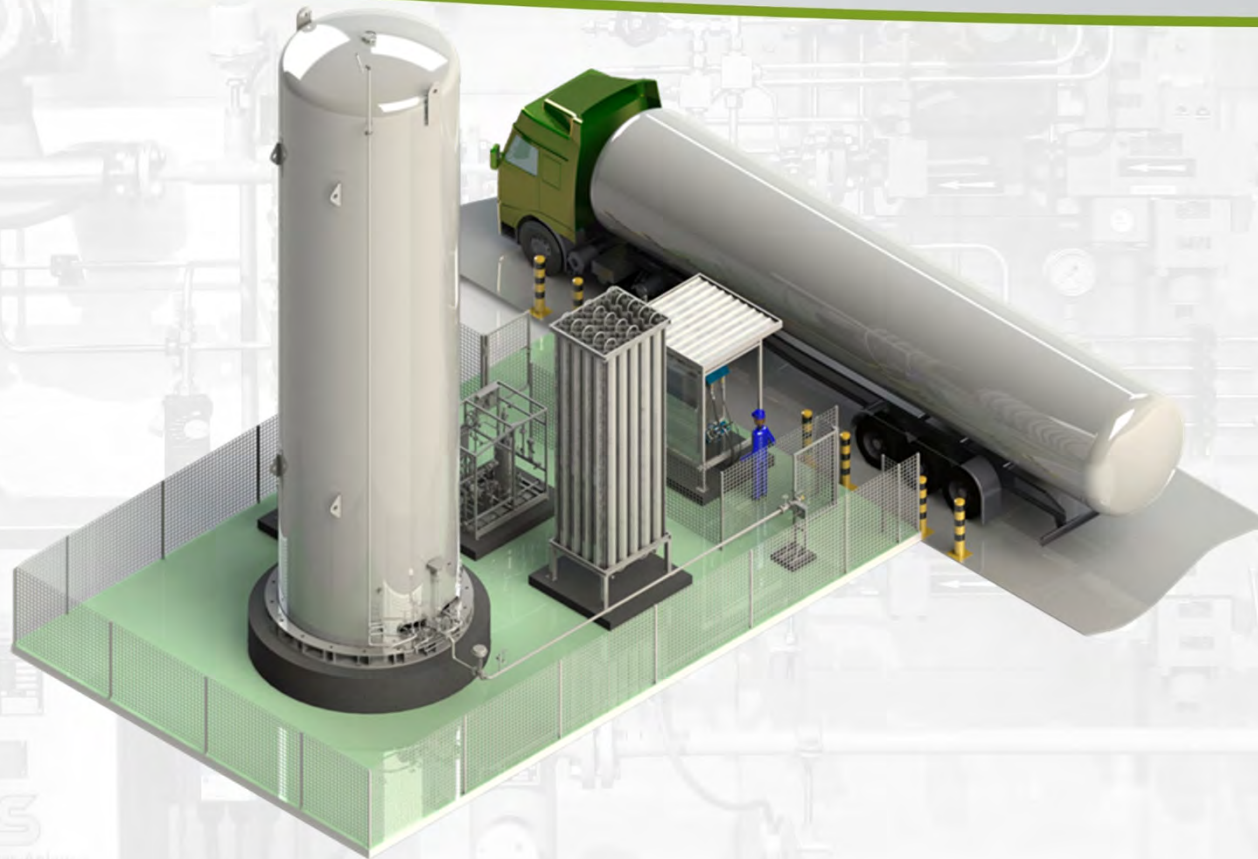

► LNG filling plant on smallest possible space (15x10m)

Standard LNG Plants – Example Systems

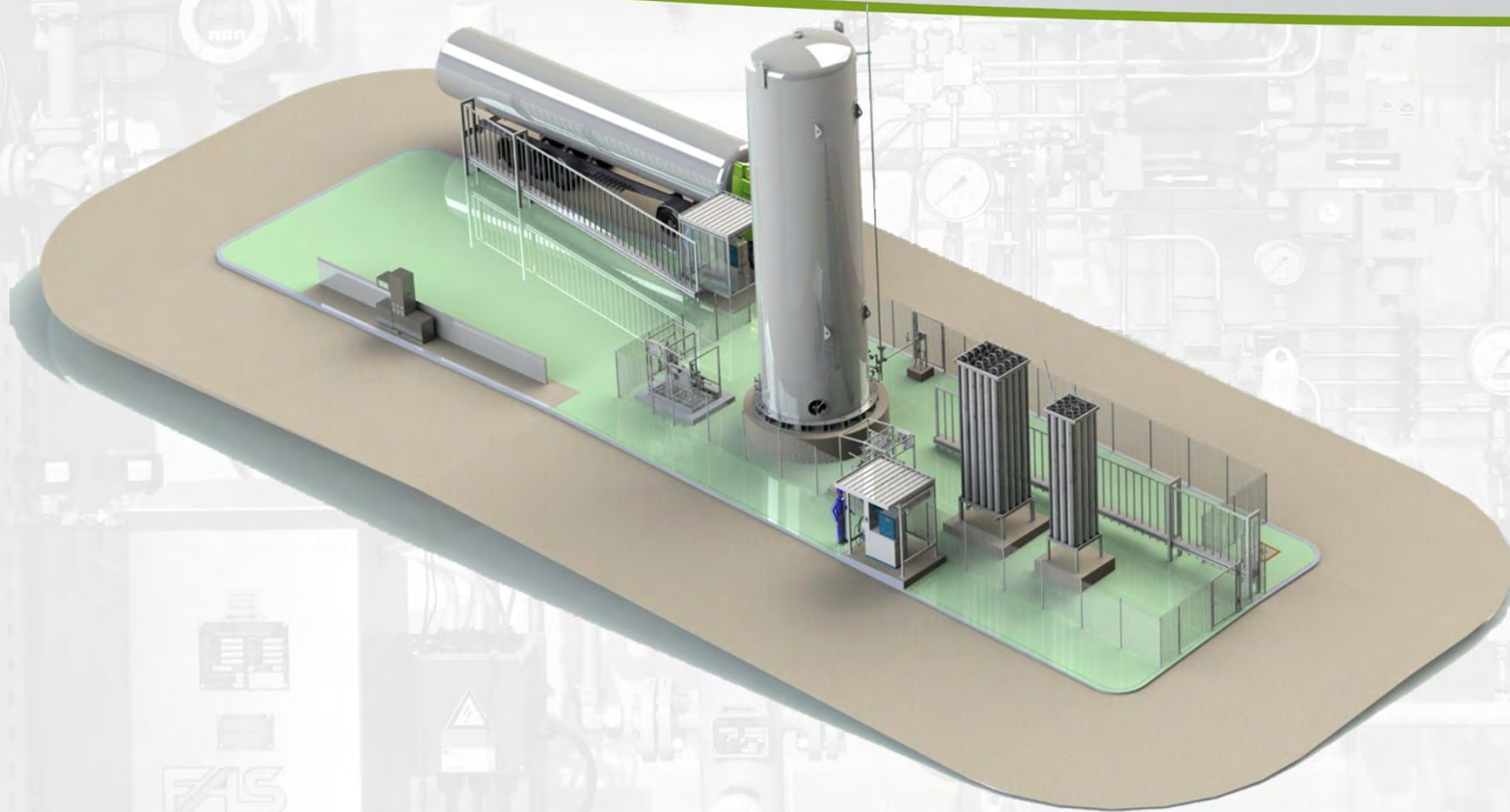

► Medium sized LNG filling plant (23x10m)



www.fas.de
www.fas-engineering.de

Standard LNG Plants – Example Systems



► Example: LNG filling station – container construction (40')



www.fas.de
www.fas-engineering.de

FAS Product Portfolio: Compact LPG Filling Station
Cylinder and Vehicle Filling with "Combi-Fill"



FAS Product Portfolio: Compact LPG Filling Stations
Cylinder and Vehicle Filling



FAS Product Portfolio: Compact LPG Filling Stations
Cylinder and Vehicle Filling – Execution on Customer Request



FAS Product Portfolio: Compact LPG Filling Stations
Cylinder and Vehicle Filling – Executions on Customer Request



FAS Product Portfolio: Compact Cylinder Filling Stations
- Cabinet Construction -



FAS Product Portfolio: Compact Cylinder Filling Stations
- Container-Version -



FAS Product Portfolio: Compact Cylinder Filling Stations - Container Version -

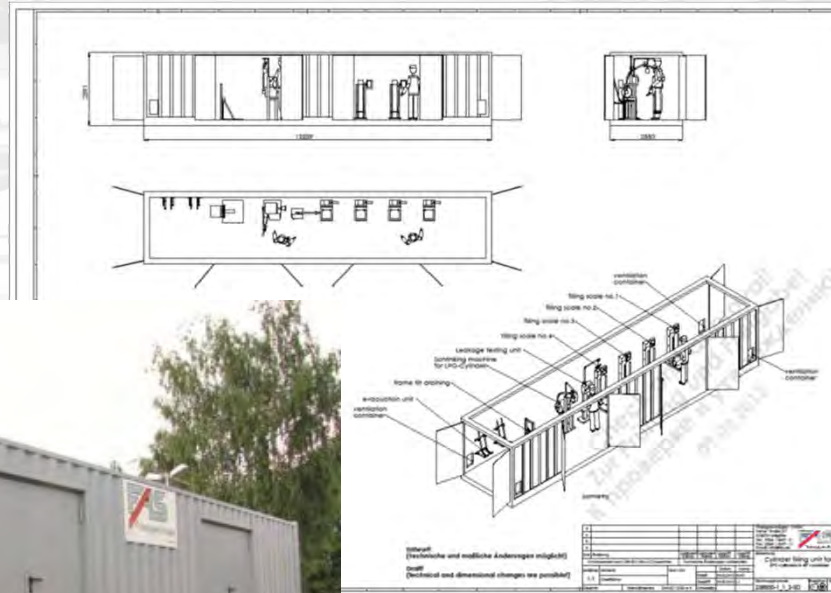

FAS Product Portfolio: Compact Cylinder Filling Stations
- Container Version -



FAS Product Portfolio: Compact Cylinder Filling Stations
- Container Version -



FAS Product Portfolio: Evacuation Unit for Gas Cylinders



FAS Product Portfolio: Evacuation Unit for Gas Cylinders

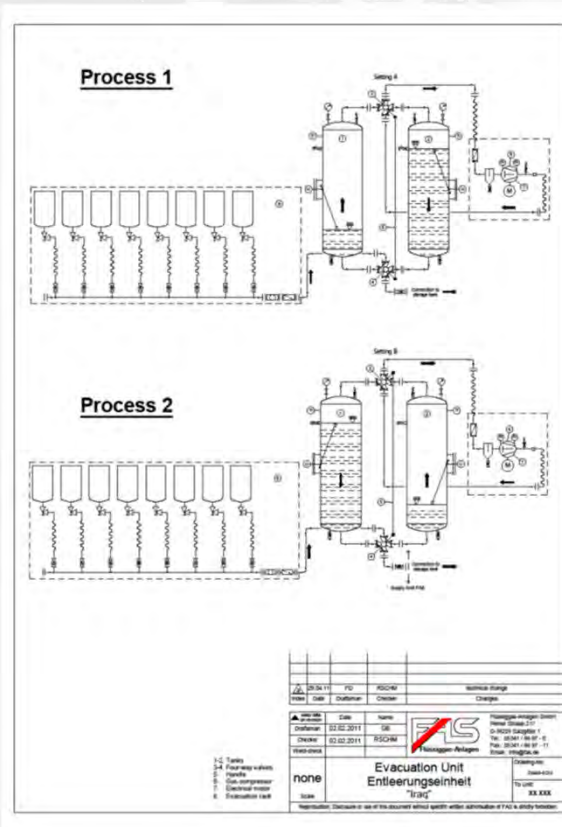

FAS Product Portfolio: Evacuation Unit for Gas Cylinders



MAINTENANCE, SERVICE, CALIBRATION



- Repair, maintenance, service and calibration of LPG dispensers and Autogas filling stations, vaporizers, compressors etc.

SERVICE DEPARTMENT



FAS-Service-Team:

- ▶ 18 experts
- ▶ 15 Service vehicles
- ▶ 3 calibration vehicles
- ▶ 7 support points in Germany

Service-Hotline:
05341 8697 88



SERVICE DEPARTMENT



FAS-Services in Germany at one glance:

- ▶ Repair, maintenance, service
- ▶ Service agreement
- ▶ 24h-phone support and hotline
- ▶ Technical help desk
- ▶ Online request
- ▶ Administration / supervision of inspection periods
- ▶ Mobile inspection technology for your Autogas dispenser



**Service-Hotline:
05341 8697 88**

FAS-TRAINING



Knowledge sharing is part of our philosophy:

- ▶ In-House Training
- ▶ Onsite Support
- ▶ Short Communication Channels
- ▶ Regular Updates



Our services at one glance:

- ▶ Consultation & requirement analysis
- ▶ Profitability assessment
- ▶ Feasibility Studies
- ▶ Customer-specific, innovative product or application development
- ▶ Project management incl. Installation, pipeline and electrical planning
- ▶ CAD design, R&I Diagrams
- ▶ Authorization and approval procedures
- ▶ Construction and progress scheduling



CERTIFICATIONS



Certified according to

- DIN EN ISO 9001:2015
- PED 97/23/EC
- SCC** (Service)

DEKRA

CERTIFICATE

ISO 9001:2015

DEKRA Certification GmbH hereby certifies that the company

Flüssiggas-Anlagen GmbH

Scope of certification:
Manufacturing, sales and service for LPG-Equipment

Certified location:
D-38229 Salzgitter, Peiner Straße 217

has established and maintains a quality management system according to the above mentioned standard. The conformity was attested with audit report no. A17011025. This certificate is only valid in connection with the main certificate no. 50613352/3.

This certificate is valid from 2018-04-11 to 2020-04-10
Certificate registration no.: 50613352/3-1

Lothar Wulfsen
 DEKRA Certification GmbH Stuttgart, 2018-04-11
 DEKRA Certification GmbH · Handwerkerstraße 15 · D-70565 Stuttgart · www.dekra-certification.de

page 1 of 1

Notifizierte Stelle für Druckgeräte
(Notified body for Pressure Equipment)

CERTIFICATE

According to directive 2014/68/EU
The notified body for pressure equipment of DEKRA
Automobil GmbH certifies, that the organization mentioned below

FAS Flüssiggas-Anlagen GmbH
Peiner Straße 217
D-38229 Salzgitter

at the manufacturing site

FAS Flüssiggas-Anlagen GmbH
Peiner Straße 217
D-38229 Salzgitter

operates an approved quality management system within the scope of

full quality assurance with design examination and special surveillance of the final assessment (Modul H1)

of

LPG-gas filling stations as assembly or their components

per module H1 design, manufacturing and final inspection
in accordance with annex III of the directive mentioned above and is entitled to affix the mark as shown below to the respective products.

CE 2266

Evidence of compliance was delivered in a quality system audit. This certificate is valid only in connection with the audit report no.: 20181120-32050-1893131423-100-421420-Bericht-ZA.

This certificate is valid until: 2021-10-14

Certificate no.: Z-D-012-12391/18

The validity of this certificate requires the successful annual review of the quality system by the notified body.

Hamburg, 15.10.2018

Zertifizierungsstelle für Druckgeräte

DEKRA Automobil GmbH, Postfach 10 10 2000 Hamburg
 Tel. 0711 78 62 20 Fax 0711 78 62 17
 www.dekra.de

Seite 1 von 1

ZERTIFIKAT CERTIFICATE CERTIFICADO CERTIFICOMKAT CERTIFICADO CERTIFICATE CERTIFICATE

CERTIFICATE

The Certification Body
of TÜV SÜD Management Service GmbH
certifies that

Flüssiggas-Anlagen GmbH
Service
Peiner Str. 217
38229 Salzgitter
Germany

has established and applies an
Occupational Safety, Health and Environmental Management System for

**Service, installation and commissioning
of LPG equipment.**

An audit was performed, Order No. 70025248.
Proof has been furnished that the normative requirements
according to

**Sicherheits Zertifikat Contractoren
(SCC** Version 2011)**

are fulfilled.
The certificate is valid from 2019-04-26 until 2022-04-27.
Certificate Registration No.: 12 106 16484 TMS.

Product Compliance Management
 Munich, 2019-04-02

TÜV SÜD Management Service GmbH · Postfach 10 10 2000 Hamburg
 www.tuev-sued.com

TUV

CERTIFICATIONS

UNI-FÖRDERTECHNIK
GmbH

NINNELT
INTERNATIONAL GmbH

FAS
Flüssiggas-Anlagen

Certified according to

- DIN EN ISO 9001:2015
- PED 97/23/EC



*Small Selection of the Product Portfolio
of our Sister Company*

NINNELT
INTERNATIONAL GmbH



FAS
Flüssiggas-Anlagen



*Type WAER 100 ex/e
with two filling
connections*



*Type WAER 100 ex/e
with one filling
connection*



*Type WAER 100ex/e
with weighing bridge*

*Small Selection of the Product Portfolio
of our Sister Company*

NINNELT
INTERNATIONAL GmbH



FAS
Flüssiggas-Anlagen



*Shrinking machine
Type MS & type AS*



*Leakage Testing Unit
Type MED1 & type AED*



*Small Selection of the Product Portfolio
of our Sister Company*

NINNELT
INTERNATIONAL GmbH



FAS
Flüssiggas-Anlagen

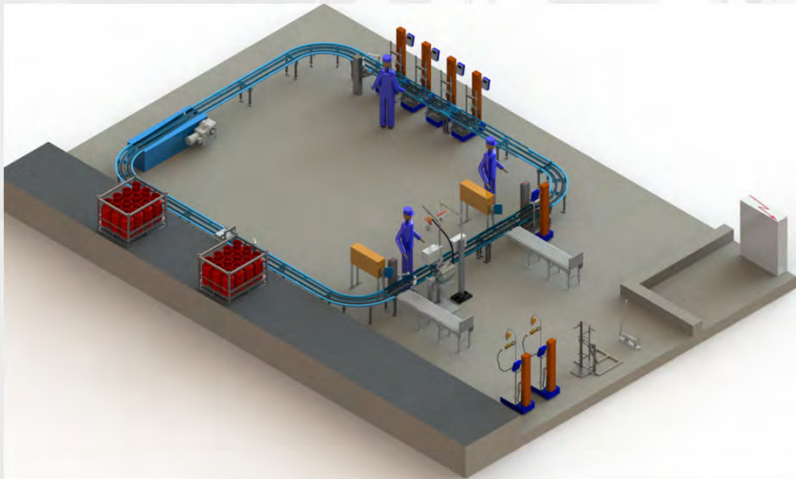

Inline Filling Station

www.fas.de

*Small Selection of the Product Portfolio
of our Sister Company*

NINNELT
INTERNATIONAL GmbH



FAS
Flüssiggas-Anlagen



Carousel Filling Plant K7E with electronic filling scale type WAER

www.fas.de

*Small Selection of the Product Portfolio
of our Sister Company*

NINNELT
INTERNATIONAL GmbH



FAS
Flüssiggas-Anlagen



Carousel Filling Plant K18E with electronic filling scale type WAER

www.fas.de



*Small Selection of the Product Portfolio
of our Sister Company*

NINNELT
INTERNATIONAL GmbH



FAS
Flüssiggas-Anlagen



FAS
Flüssiggas-Anlagen

Palletizing Unit

www.fas.de

*Small Selection of the Product Portfolio
of our Sister Company*

NINNELT
INTERNATIONAL GmbH



FAS
Flüssiggas-Anlagen

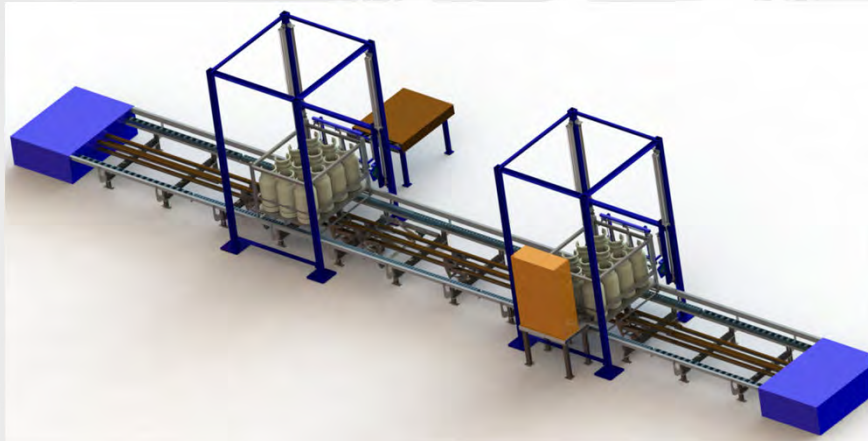

Palletizing Unit

www.fas.de

Small Selection of the Product Portfolio
of our Sister Company **UNI-FÖRDERTECHNIK**
GmbH



Hose reels for fire protection, automatic filter for colour, rotary vane pumps for CO2

Small Selection of the Product Portfolio
of our Sister Company **UNI-FÖRDERTECHNIK**
GmbH



*Solutions for handling and
processing of liquid media*

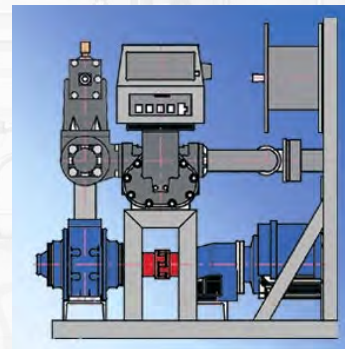

Automatic filter systems, fittings, hose reels

Small Selection of the Product Portfolio
of our Sister Company **UNI-FÖRDERTECHNIK**
GmbH

FAS
Flüssiggas-Anlagen



Pumps, compressors, filters



CUSTOMER SERVICE

CUSTOMER
FEEDBACK
SUPPORT
INNOVATION
QUALITY
EXCELLENCE
FRIENDSHIP



CORNER STONES FOR A JOINT SUCCESS



- **3 COMPANIES** IN THE FAS-GROUP
- **18 SERVICE CARS**
- **200 EMPLOYEES** AT YOUR SERVICE
- **1000 m²** STORAGE AREA FOR YOUR PRODUCTS
- **30.000** STORED ITEMS FOR OPTIMAL DELIVERY CAPABILITY
- **97,4 %** CUSTOMER SATISFACTION (QM 2015)



FAS WORLDWIDE



- ▶ FAS is represented worldwide with own offices or partners.

Would you like to join our team?



LPG, LNG, CNG Industrial Management



➤ ONE TEAM ➤ ONE WORLD ➤ ALL GASES



**“Quality remains long
after the price has been forgotten.”**

(Gottlieb Daimler)



www.fas.de
www.fas-engineering.de

