

**Section E**  
**Globe and Angle Valves**

**E**

# Limited 10 Year Warranty and Limitation Of Liability

## LIMITED 10 YEAR WARRANTY

RegO warrants to the original purchasers the products and repair kits manufactured by it to be free from defects in materials and workmanship under normal use and service for a period of 10 years from the date of manufacture. If within thirty days after buyer's discovery of what buyer believes is a defect, buyer notifies in writing and ships the product to RegO at 100 RegO Drive, Elon, NC 27244, RegO, at its option, and within forty-five days of receipt, will repair, replace F.O.B. point of manufacture, or refund the purchase price of that part or product found by RegO to be defective. Failure of buyer to give such written notice and ship the product within thirty days shall be deemed an absolute and unconditional waiver of any and all claims of buyer arising out of such defect.

This warranty does not extend to any product or part that is not installed and used after installation in accordance with RegO's printed instructions, all applicable state and local regulations, and all applicable national standards, such as those promulgated by NFPA, DOT and ANSI. This warranty does not extend to any product or part that has been damaged by accident, misuse, abuse, failure to maintain, or neglect, nor does it extend to any product or part which has been modified, altered, disassembled, or repaired in the field. This warranty does not cover any cosmetic issues, such as scratches, dents, marring, fading of colors or discoloration.

Except as expressly set forth above, and subject to the limitation of liability below, RegO MAKES NO OTHER WARRANTY, EXPRESS OR IMPLIED, INCLUDING, BUT NOT LIMITED TO, THE IMPLIED WARRANTIES OF MERCHANTABILITY AND FITNESS FOR A PARTICULAR PURPOSE, with respect to its products and parts, whether used alone or in combination with others. RegO disclaims all warranties not stated herein.

## LIMITATION OF LIABILITY

RegO's total liability for any and all losses and damages arising out of any cause whatsoever shall in no event exceed the purchase price of the products or parts in respect of which such cause arises, whether such cause be based on theories of contract, negligence, strict liability, tort or otherwise.

RegO shall not be liable for incidental, consequential or punitive damages or other losses. RegO shall not be liable for, and buyer assumes any liability for, all personal injury and property damage connected with the handling, transportation, possession, further manufacture, other use or resale of products, whether used alone or in combination with any other products or materials.

From time to time buyers might call to ask RegO for technical advice based upon limited facts disclosed to RegO. If RegO furnishes technical advice to buyer, whether or not at buyer's request, with respect to application, further manufacture or other use of the products and parts, RegO shall not be liable for such technical advice or any such advice provided to buyer by any third party and buyer assumes all risks of such advice and the results thereof.

**NOTE: Some states do not allow the exclusion or limitation of incidental, consequential or punitive damages, so the above limitation or exclusion may not apply to you. The warranty gives you specific legal rights, and you may have other rights that vary from State to State. The portions of this limited warranty and limitation of liability shall be considered severable and all portions which are not disallowed by applicable law shall remain in full force and effect.**

## WARNING

All RegO products are mechanical devices that will eventually become inoperative due to wear, corrosion and aging of components made of material such as rubber, etc. The environment and conditions of use will determine the safe service life of these products. Periodic inspection and maintenance are essential to avoid serious injury and property damage.

Many RegO products are manufactured components which are incorporated by others on or in other products or systems used for storage, transport, transfer and otherwise for use of toxic, flammable and dangerous liquids and gases. Such substances must be handled by experienced and trained personnel only, using accepted governmental and industrial safety procedures.

## NOTICE TO USERS OF PRODUCTS

The Limited Warranty stated above is a factory warranty to the first purchasers of RegO products. Since most users have purchased these products from RegO distributors, the user must within thirty (30) days after the user's discovery of what user believes is a defect, notify in writing and return the product to the distributor from whom he purchased the product/part. The distributor may or may not at the distributor's option choose to submit the product/parts to RegO, pursuant to this Limited Warranty. Failure by buyer to give such written notice within thirty (30) days shall be deemed an absolute and unconditional waiver of buyer's claim for such defects. Acceptance of any alleged defective product/parts by RegO's distributor for replacement or repairs under the terms of RegO's Limited Warranty in no way determines RegO's obligations under this Limited Warranty.

Because of a policy of continuous product improvement, RegO reserves the right to change designs, materials or specifications without notice.

# Foreword

This catalog describes a complete line of equipment available from RegO® for use with Liquid Propane (LP)-Gas and anhydrous ammonia (NH<sub>3</sub>). The following points are important to know for proper use of the catalog:

1. Illustrations and drawings of individual products are representative of “product groups” and all products within a product group are similar in construction.
2. Materials used for construction of products in this catalog are suitable for rated service pressure at temperatures of -40°F to +165°F, unless otherwise specified.
3. Products in this catalog are only intended for use in LP-Gas and/or anhydrous ammonia service as follows.
  - a. “A” or “AA” prefix — Products with this prefix are suitable for NH<sub>3</sub> service (i.e., contain no brass parts).
  - b. “AA” prefix on relief valves — These valves are NOT suitable for use with LP-Gas service. These are of partial aluminum materials and are listed by Underwriters Laboratories (UL) for NH<sub>3</sub> service only.
  - c. All other products including “A” prefix are suitable for use with LP-Gas & NH<sub>3</sub> service.
  - d. “SS” prefix—Hydrostatic relief valve with this prefix are suitable for NH<sub>3</sub> and LP-Gas service (i.e., they have stainless steel materials).
4. We manufacture valves and adapters designed to be used on LP-Gas and Anhydrous Ammonia systems, we do not design systems or consult in system design. For this type of information consult a professional Engineer.

## Caution

Do not use any product contained in this catalog with any service commodity other than LP-Gas or NH<sub>3</sub>. If you have a need for use of another application, contact RegO, 100 RegO Drive, Elon, NC 27244, (336) 449-7707 [ecii@regoproducts.com](mailto:ecii@regoproducts.com) before proceeding.

Proper application, installation and maintenance of products in this catalog are essential. Users of these products should obtain further information if there are any doubts or questions.

## Warning

All RegO products are mechanical devices that will eventually become inoperative due to wear, corrosion and aging of components made of materials such as rubber. The environment and conditions of use will determine the safe service life of these products. Periodic inspection and maintenance are essential to avoid serious injury and property damage.

Many RegO products are manufactured for storage, transport, transfer and use of toxic flammable and dangerous liquids and gases. Such substances should be handled by experienced and trained personnel only, using accepted governmental and industrial safety procedures. Never vent LP-Gas near any possible source of ignition.

## Notice

Installation, usage, and maintenance of all RegO products must be in compliance with all RegO instructions as well as requirements and provisions of NFPA #54, NFPA#58, DOT, ANSI, and all applicable federal, state, provincial and local standards, codes, regulations, and laws.

Inspection and maintenance on a periodic basis is essential. Installation and maintenance should be performed only by qualified personnel.

Be sure all instructions are read and understood before installation, operation and service.

## Filters

RegO LP-Gas equipment is designed to operate in a system free from contamination. A variety of in-line filters are commercially available to the LP-Gas industry for installation in domestic systems.

The use of an in-line filter should be considered when other system components may be unclean and the system contaminated by rust, scale, dirt, debris or other foreign material.

# LP-Gas Hose-End Filling Valves (With ACME Connectors)

## Safety Warnings



### Purpose

In its continuing quest for safety, RegO publishes a series of bulletins explaining the hazards associated with the use, misuse, and aging of LP-Gas valves and regulators. It is hoped that these factual bulletins will make clear to LP-Gas dealer managers and service personnel, that the utmost care and attention must be used in the installation, inspection, and maintenance of these products, or problems could occur which would result in injuries and property damage.

The National Fire Protection Association NFPA 58 Liquefied Petroleum Gas Code - 2017 Edition states in Section 4.4 Qualification of Personnel; "Persons whose duties fall within the scope of this code shall be provided with training that is consistent with the scope of their job activities and that includes proper handling and emergency response procedures. Refresher training shall be provided at least every 3 years, initial and subsequent training shall be documented". These "RegO Safety Warnings" may be useful in training new employees and reminding older employees of hazards that can occur. It is recommended that all employees complete the Propane Education Research Council's Certified Employee Training Program.

## Nature of Warnings

It is recognized that warnings should be as brief as possible, but factors involved in filler valve and filling valves failure are not simple. They need to be fully understood so that proper procedures and maintenance can be used to prevent accidents. If there is a simple warning, it would be:

**Loosen filling valve from filler valve very slowly. If there is a leak, know procedure to follow.**

This bulletin is not intended to be an exhaustive treatment of the subject of filler valves and certainly does not cover all safety practices that should be followed in the installation, operation and maintenance of LP-Gas systems, which include filler and filling valves.

### Hose-End Filling Valves With ACME Connectors

Hose-end valves must never be dragged over the ground or dropped or banged into the truck when the hose is reeled in.

They could open accidentally or they could be damaged. Dragging will cause abnormal wear and eventual valve failure. Foreign material will lodge in the connector which can cause failure of the filler valve.

To prevent hazardous conditions, operators should follow this procedure on every filling application:

Always wear gloves and eye protection.

Check for foreign material in hose-end valve and the filler valve, and if present, remove with extreme care. If material cannot be safely removed, do not proceed with filling and replace valve.

Make sure the ACME connector spins on easily by hand.

If leak is noticed when filling is started, stop the operation and correct the leaking condition.

After filling, bleed the gas trapped between the filler valve and hose-end valve by using the vent on the hose-end valve or by slightly loosening coupling nut to vent the gas before disconnecting.

**If gas does not stop venting, then filler valve or hose-end valve is leaking. Do not disconnect filling connector. This is a hazardous situation and your company procedure for handling this problem must be carefully followed.**

### Make sure your company has such a procedure. Inspection of Filling Valves with Handwheel

Valves should be inspected at least once a month to be sure that the valve handle is tight and not damaged, that the stem is not bent and that there is no "play" in the threads in the bonnet. "Play" will normally not be noticed if the valve is under pressure.

The ACME threads should be examined for wear, dents or nicks and the seating area should be clean and smooth.



Loosen slowly. If gas continues to vent, retighten ACME connector and follow company emergency procedures.

### Inspection of Quick Acting Filling Valves

Valves should be inspected daily to make sure locking mechanism functions properly.

The ACME threads should be examined for wear, dents or nicks and the seating area should be clean and smooth.

The retaining ring on the filler connection should be examined to make sure it is properly holding the female ACME rotating nut or handle so as to keep the surface that seats on the filler valve gasket protected.

If any problems are evident, valves should be immediately replaced or repaired.

### Larger Filler and Filling Valves

For 2¼" and 3¼" valves with ACME connections, use only the special wrenches designed for the purpose.

Do not use pipe wrenches or hammers to tighten the connections. All of the previous warnings about the smaller valves also apply here.

### General Warning

All RegO products are mechanical devices that will eventually become inoperative due to wear, contaminants, corrosion and aging components made of materials such as rubber and metal. The environment and conditions of use will determine the safe service life of these products. Periodic inspection and maintenance are essential. Because RegO products have a long and proven record of quality and service, LP-Gas dealers may forget the hazards that can occur because a filler valve or a filling valve is used beyond its safe service life. Life of these valves is determined by the environment in which they "live." The LP-Gas dealer knows better than anyone what this environment is. Note: There is a developing trend in state legislation and in proposed national legislation to make the owner of products responsible for replacing products before they reach the end of their safe useful life. LP-Gas dealers should be aware of the legislation which could affect them.

# Quick-Acting Minimum Loss Hose-End Valves for Bobtail Delivery Trucks and Dispensing Stations A7793A and A7797A

## Application

Designed to vastly reduce the amount of product vented when disconnecting bobtail delivery trucks, dispensing systems and anhydrous ammonia nurse tanks. These valves provide instant, full-on flow at the flip of a handle. Shut-off is instant and the handle locks for added protection. This "top of the line" hose-end valve is a fully contained unit that does not require additional filling adapters or connectors.

## Features

- Minimizes product venting loss, when disconnecting, instantly by housing the seat disc at the bottom of the built-in ACME filling connector.
- Vents less than 2cc of liquid when disconnected.
- "V"-ring spring-loaded pressure seal design provides for dependable, leak-free operation. No packing to retighten or replace.
- Operator friendly. Contoured handle rotates a full 360° and large, easy to grip filling connector make the valve easy to handle.
- Self locking handle is operator opened and closed to prevent against accidental opening of the valve.

## Materials

Body .....	Ductile Iron
"V"-Ring .....	Teflon
Stem .....	Stainless Steel
Seat Disc .....	Synthetic Elastomer
ACME Connector.....	Aluminum w/Steel Insert
Seal Housing .....	Stainless Steel
Lever.....	Stainless Steel
Bonnet .....	Cadmium Plated Steel



**A7793**

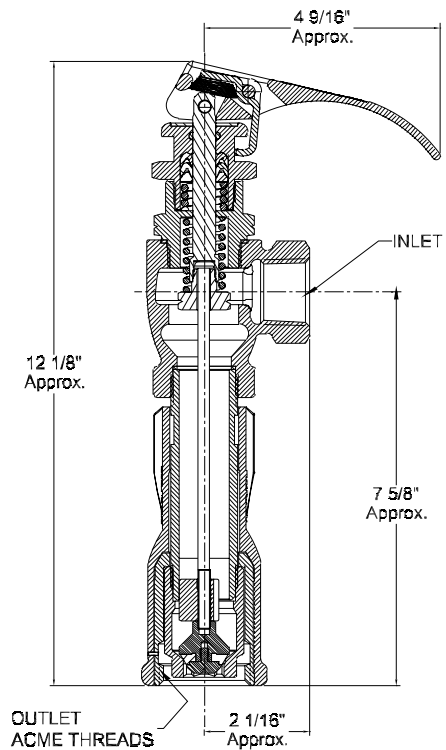

## Ordering Information

Part Number	Inlet Connection (F. NPT)	Outlet Connection (F. ACME)	Locking Handle	Flow at 1 PSIG (Cv) Pressure Drop* (GPM/Propane)
<b>A7793A</b>	3/4"	1 3/4"	Yes	16.0
<b>A7797A</b>	1"	1 3/4"	Yes	16.0

\* To obtain approximate flow at other than 1 PSIG pressure drop, multiply flow in table by square root of pressure drop. Example: A7797 @ 9 PSIG = 16.0 x√9 = 48.0 GPM/propane. For NH<sub>3</sub> flow, multiply propane flow by .90.

# Quick-Acting Hose-End Valves for Bobtail Delivery Trucks and Dispensing Stations A7707L and A7708L

## Application

Designed especially for safe operator handling of LP-Gas in bobtail delivery truck, dispensing systems and anhydrous ammonia nurse tank service.

These valves provide instant, full-on flow at the flip of the handle and provide instant positive shut-off with a handle lock for added protection.

## Features

- "V"-ring spring-loaded pressure stem seal provides for leak-proof operation. No packing to retighten or replace.
- Self locking handle is operator opened and closed to prevent against accidental opening of the valve.
- Large, contoured handle provides firm, comfortable grip.
- Full swivel handle rotates 360° so the valve can be operated from any angle.
- Built-in vent valve on the downstream side of the valve permits bleeding of trapped product to ensure safe uncoupling.
- Can be used with a variety of RegO filling adapter connectors.
- Swivel seat disc minimizes grinding on the body seat and ensures longer service life.

## Materials

Body .....	Ductile Iron
"V"-Ring .....	Teflon
Stem .....	Stainless Steel
Seat Disc .....	Synthetic Elastomer
Valve Lever .....	Stainless Steel
Seal Housing .....	Stainless Steel
Bonnet .....	Cadmium Plated Steel

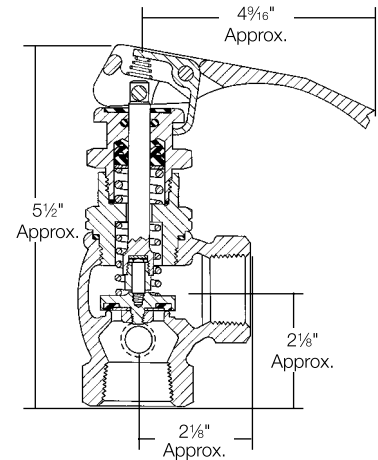
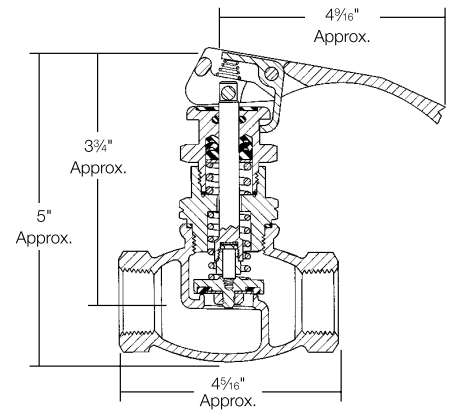

E

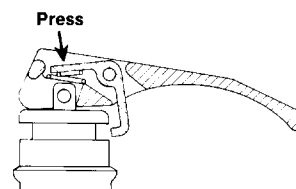

Spring-Loaded Thumb-Button Opens Latch

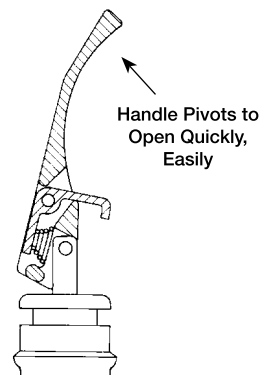

## Ordering Information

Part Number	Body Design	Inlet & Outlet Connection (F. NPT)	Locking Handle	Flow at 1 PSIG Pressure Drop (Cv) (GPM/Propane)**	Accessories		
					Filling Connectors**		
					Extended Steel	Compact Brass Steel	
A7707L	Straight	1"	Yes	18.0	A7575L4	3175A	A3175A
A7708L	Angle			22.0			

\* To obtain approximate flow at other than 1 PSIG pressure drop, multiply flow in table by square root of pressure drop. Example: A7708L @ 9 PSIG = 22.0 x √9 = 66.0 GPM/propane. For NH<sub>3</sub> flow, multiply propane flow by .90.

\*\* See appropriate catalog section for additional information.

# New 2" ACME Low Emission Hose End Valve for Loading Bobtails and Transports A7914A

## Application

The A7914A Low Emission valve is designed to reduce the amount of product vented when disconnecting bobtail and transport loading hoses. This valve provides a full-on flow when pressing the release trigger and the lifting of an easy grip handle. Lowering the handle will immediately stop flow and lock the lever in the closed position. This valve can be used with any standard 3/4" Male ACME connector, or our 6588LE and 6589LE minimum loss filler valves.

## Features

- Minimizes product discharge at disconnect.
- Vents **less than 2 cc of liquid when disconnected.**
- **California CARB Compliant for fugitive emissions.**
- Contoured handle rotates 360° and has a large easy to turn ACME swivel connector.
- Self-locking handle is operator opened and closed, designed to prevent accidental opening of the valve.
- Bypass mechanism in the seat area allows the upstream pressure to quickly equalize when the handle is partially moved to the open position.
- Protective screen on inlet side prevents debris from entering.
- Spring-loaded Teflon "V" packing for bonnet/stem assembly provides long service life.

## Materials

Body ..... Ductile Iron  
 "V" -Rings..... Teflon  
 Stem ..... Stainless Steel  
 Acme Connector..... Plated Ductile Iron  
 Seal Housing ..... Stainless Steel  
 Bonnet ..... Plated Steel  
 Lever..... Stainless Steel  
 Seat Disc ..... Synthetic Rubber



**A7914A**

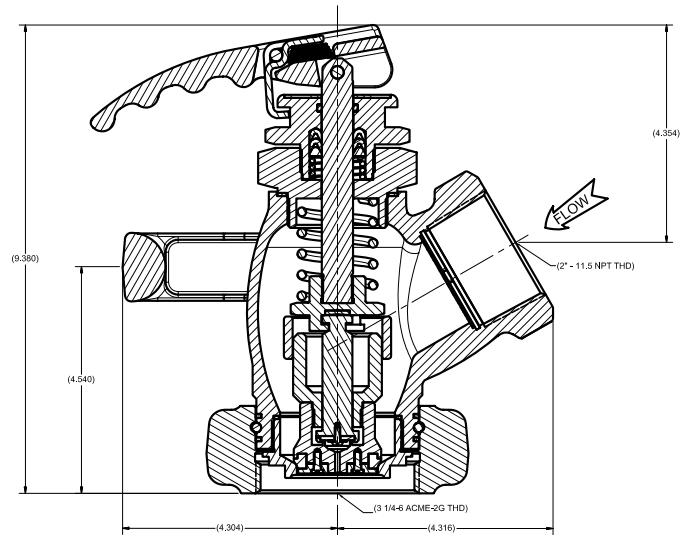

## Ordering Information

Part Number	Inlet Connection	Outlet Connection	Locking Handle	Flow at (Cv) Pressure Drop GPM Propane	
				1 PSIG	10 PSIG
<b>A7914A</b>	2" F.NPT	3/4" F.Acme	Yes	55	174

\*To obtain approximate flow at other than 1 PSIG drop, multiply flow in table by square root of pressure drop. Example A7914 @ 9PSIG drop = 55 X  $\sqrt{9}$  = 165 GPM /propane

# Quick-Acting Valves for Crop Driers and Charging Manifold Hoses

## 7554 Series

### Application

7554S Series valves provide instant shut-off and fast opening control on LP-Gas crop driers. They are also ideal for charging manifold hoses, stationary fuel transfer hoses and other applications requiring quick, positive shut-off. They are not for use with delivery truck hoses because the handle could snag on the ground and open the valve as the hose is reeled back to the truck.

7554L Series valves feature a locking handle device to help prevent accidental opening of the valve. It is ideal for all the same applications as the 7554S Series and may be used on delivery trucks as it incorporates the locking handle design.

Both valve series must be installed so that flow through the valve is opposite to that of a conventional globe valve. This allows the inlet flow to assist in closing the valve and prevents the valve from being opened by high pump pressures.

### Features

- Quick-acting design speeds transfer operations, permitting rapid, one-handed opening and closing.
- Resilient seat disc provides positive shut-off.
- Flange seal stem design provides for leak-proof operation. No packing to retighten or replace.
- 7554L Series incorporates locking handle to prevent accidental opening of the valve.
- Vent valve installed on the downstream side of the valve permits bleeding of trapped product to ensure safe uncoupling.
- Swivel seat disc minimizes grinding on the body seat and ensures longer service life.

### Materials

Body .....	Ductile Iron
Bonnet .....	Brass
Stem Seal .....	Teflon
Stem .....	Stainless Steel
Seat Disc .....	Nitrile Elastomer
Seal Housing .....	Brass
Lever .....	Brass



7554S

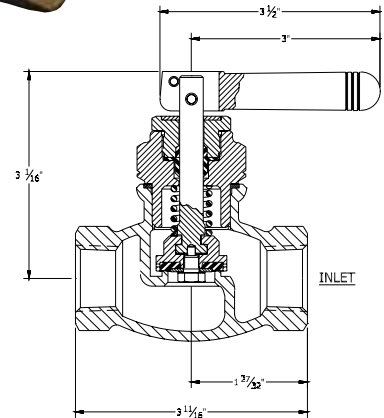

7554LV

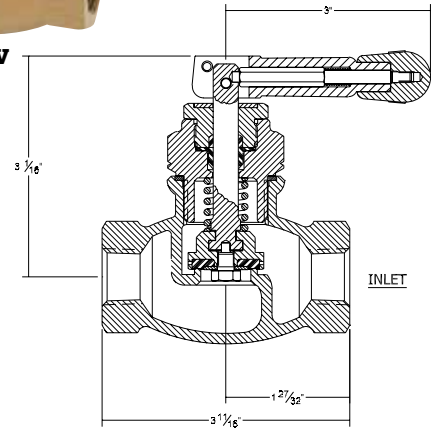

### Ordering Information

Part Number	Inlet & Outlet Connection (F. NPT)	Locking Handle	Flow At 1 PSIG (Cv) Pressure Drop* (GPM/Propane)
7554SAV	1/2"	No	7.3
7554LAV		Yes	
7554SV	3/4"	No	11.3
7554LV		Yes	

\* To obtain approximate flow at other than 1 PSIG pressure drop, multiply flow in table by square root of pressure drop. Example: 7554LV @ 9 PSIG = 11.5 X  $\sqrt{9}$  = 34.5 GPM/propane.



# Quick-Acting Valves for Cylinder Charging Hoses 7053T and 7901T Series

## Application

Designed primarily for use on cylinder charging hoses to provide fast, convenient shut-off and fast opening.

These valves must be installed so that flow through the valve is in the opposite direction to that of a conventional globe valve. This allows the inlet flow to assist in closing the valve, and even more important, helps prevent the valve from being forced open by high pump pressure.

## Features

- Quick-acting design speeds transfer operations.
- Permits easy, one-handed opening and closing of the valve.
- O-ring stem seal design.
- Provides quick, positive shut-off.

## Materials

Body (7053T, 7901) ..... Forged Brass  
 O-Ring ..... Resilient Synthetic Rubber  
 Bonnet Assembly (7053T, 7901)..... Brass  
 Seat Disc ..... Resilient Synthetic Rubber  
 Handle (7053T, 7901)..... Brass  
 Springs ..... Stainless Steel



**7901T**

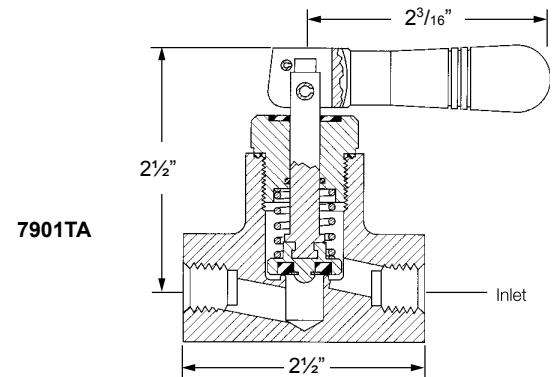

**7901TA**

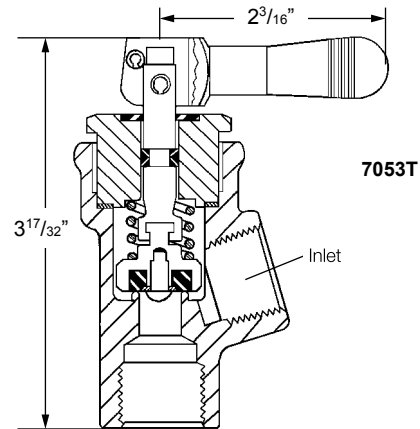

**7053T**



## Ordering Information

Part Number	Inlet Connection (F. NPT)	Outlet Connection (F. NPT)	Body Material	Flow At 1 PSIG (CV) Pressure Drop* (GPM/Propane)
<b>7901T</b>	1/4"	1/4"	Brass	1.95
<b>7901TA</b>	3/8"	3/8"		
<b>7901TB</b>	1/2"	1/4"		
<b>7901TC</b>		1/2"		
<b>7053T</b>				

\* To obtain approximate flow at other than 1 PSIG pressure drop, multiply flow in table by square root of pressure drop. Example: 7901T @ 9 PSIG =  $\sqrt{9} \times 1.95 = 5.85$  GPM/propane. For NH3 flow, multiply propane flow by .90.

# Quick-Acting Valves for Dispensing Hoses 7901TL Series

## Application

Designed primarily for use on dispensing hoses to provide safe, convenient shut-off and fast opening. These valves feature a locking handle device to help prevent accidental opening of the valve.



## Features

- Quick-acting design speeds transfer operations.
- Permits easy, one-handed opening and closing of the valve.
- O-ring stem seal design.
- Provides quick, positive shut-off.
- Locking handle device is operator opened and closed to prevent against accidental opening of the valve.

## Materials

Body .....	Forged Brass
O-Ring .....	Resilient Synthetic Rubber
Bonnet Assembly .....	Brass
Seat Disc .....	Resilient Synthetic Rubber
Handle .....	Brass
Springs .....	Stainless Steel



**7901TL Series**



## Ordering Information

Part Number	Inlet Connection (F. NPT)	Outlet Connection (F. NPT)	Body Material	Flow At 1 PSIG (CV) Pressure Drop* (GPM/Propane)
7901TLA	3/8"	3/8"	Brass	1.95
7901TLB	1/2"	1/4"		
7901TLC		1/2"		

\* To obtain approximate flow at other than 1 PSIG pressure drop, multiply flow in table by square root of pressure drop. Example: 7901T @ 9 PSIG =  $1.95 \times \sqrt{9} = 5.85$  GPM/propane. For NH3 flow, multiply propane flow by .90.

# Quick-Acting Valves for Dispensing Hoses with Low Emission Hose End Safety Adapter 7993 Series

## Application

Designed primarily for use on dispensing hoses to provide fast, convenient shut-off and fast opening with minimal release of product on disconnect.



## Ordering Information

Part Number	Inlet Connection (F. NPT)	Outlet Connection (F. NPT)	Body Material
7993AD-10L	3/8"	M. POL (CGA 510)	Brass
7993AU-10L		Type 1 Connection (1 <sup>5</sup> / <sub>16</sub> ) F. ACME	
7993BD-10L		M. POL (CGA 510)	
7993BU-10L	1/2"	Type 1 Connection (1 <sup>5</sup> / <sub>16</sub> ) F. ACME	
7993CD-10L		M. POL (CGA 510)	
7993CU-10L		Type 1 Connection (1 <sup>5</sup> / <sub>16</sub> ) F. ACME	

# “V”-Ring Seal Globe and Angle Valve Information

## General Information

RegO Globe and Angle Valves are designed and manufactured especially to meet the rigid requirements of the LP-Gas industry. The high quality construction and wide variety of sizes and styles also make them highly suited to many other industries such as anhydrous ammonia, chemical and petrochemical.

These ductile iron valves are available in both threaded and flanged connections. Threaded connections are available in ½” F. NPT to 3” F. NPT sizes. Flanged connections are available in 1½”, 2” and 3” pipe sizes.

The ductile iron used in these valves has a 60,000 PSIG tensile strength which closely approaches that of steel castings. Its yield strength of 45,000 PSIG and elongation of 15% is also comparable to that of steel castings. These material features ensure the ability of the valve body to withstand impact, wrenching stresses and thermal shock. This ductile iron conforms to ASTM specification A395.

RegO globe and angle valves are designed for working pressures up to 400 PSIG WOG and for operating temperatures from -40° F. to +160° F.

## “V”-Ring Stem Seal

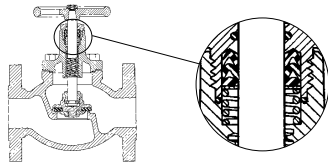

The “V”-ring spring-loaded pressure seal used in these RegO globe and angle valves is the most effective stem seal yet developed. It should not be confused with conventional valve stem packing where the seal is obtained by compressing the packing around the stem by means of a packing gland with resultant hard operation and frequent packing replacement.

The wax like surface of the teflon “V”-ring seal and consequent low friction ensures leak-tight performance for an indefinite period where periodic retightening of the packing is not required and the seal provides extra long service life.

In the RegO “V”-ring design, the seal is effected by the pressure expanding the “V”-shape of the seal, forcing it against the stem and bonnet surfaces to prevent leakage. The higher the pressure within the valve, the more effective the seal becomes. A spring loaded washer under the “V”-rings keeps them in an expanded position to ensure an effective seal under low pressure conditions. A wiper ring, located above the seal, keeps the seal free from grit, and/or other foreign material that may hamper operation.

## Installation and Operation Note

Containers and pipe lines should be thoroughly cleaned before globe and angle valves are installed. Large particles of solid foreign matter can permanently damage the seating surface in the valve body, causing the valve to leak. Use a minimum amount of a suitable pipe dope on the male connecting threads as excess amounts may fall off and be carried into the valve, causing damage to the seat or other operating parts.

It is totally unnecessary to use excess force in opening or closing RegO valves. The type of seat disc material used and the general design of these valves permits them to be opened and closed easily. Proper valve operation insures unusually long life.

Wrenches must never be used to operate valves equipped with handwheels and designed for hand operation.

## Downstream Accessory Boss

These RegO valves incorporate a plugged ¼” F. NPT boss on the downstream side of the body for attaching either a hydrostatic relief valve or vent valve. Boss size on the 2” and 3” valves has been increased to allow a ¾” drilling for accommodation of a standard by-pass valve or jumper lines.

**Hydrostatic Relief**—When the design of the piping installation is such that liquid may be locked between two shut-off valves, a hydrostatic relief valve should be installed in the lines between the valves. The pressures which can develop due to temperature increase in a liquid fill line are tremendous and can easily damage the valves or piping unless a hydrostatic relief valve is installed.

**Vent Valve**—If the globe or angle valve is used as a shut-off valve on a loading hose, a vent valve should be installed in the downstream boss to allow liquid trapped beyond the shut-off valve to be vented before disconnecting the hose coupling.

## Replace Gate Valves with Flanged Valves

Except for standard flange sizes, RegO Flanged Globe and Angle Valves are smaller and lighter than contemporary valves, thus reducing price and shipping costs and making them far easier to install. RegO face-to-face flange dimensions conform to gate valve dimensions, making replacement of most gate or plug valves with RegO valves simple and easy.

## General Features

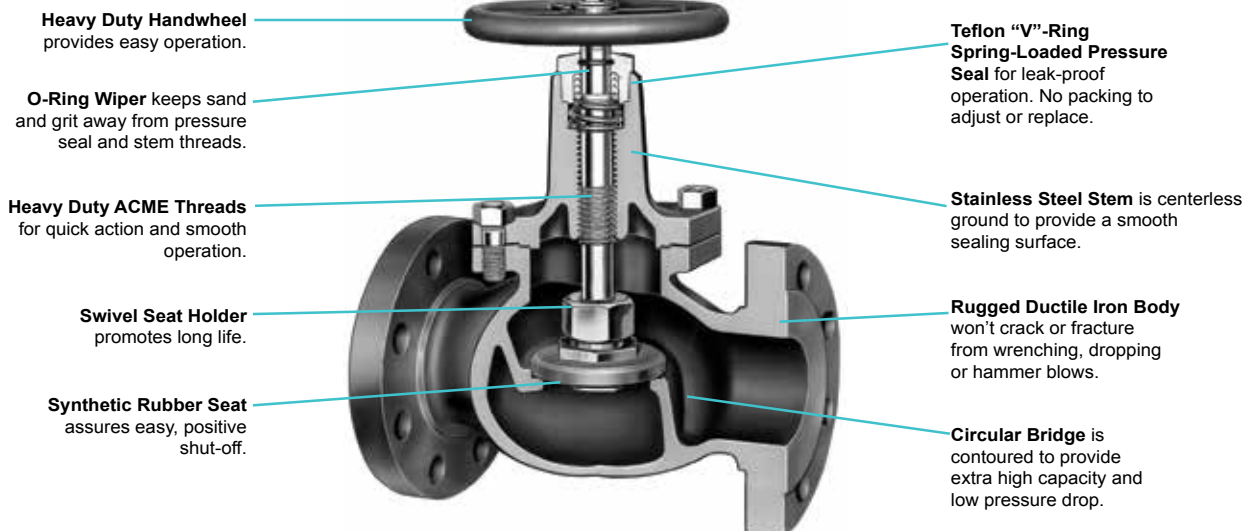

# "V"-Ring Seal Globe and Angle Valves for Bulk Storage Containers, Transports, Bobtails and Plant Piping A7500 Series and TA7500 Series

## Application

Specifically designed to ensure positive shut-off and long, maintenance free service life in liquid or vapor service on bulk storage containers, transports, bobtails, cylinder filling plants and plant piping.

The high quality construction and wide variety of sizes make them highly suited for use with LP-Gas, anhydrous ammonia and in the chemical and petrochemical industries.

## Features

- "V"-ring spring-loaded pressure stem seal provides for leak-proof operation. No packing to retighten or replace.
- Circular bridge in the globe design and a dropped seat in the angle design achieve greater flow with less pressure drop.
- Swivel seat disc assembly minimizes the seat disc from grinding on the body seat. The seat disc stops rotating as soon as it touches the body seat. This feature provides for good seat alignment and ensures long seat life.
- ¼" F. NPT plugged boss on the downstream side of the valve body allows attachment of a hydrostatic relief valve or vent valve.
- "V"-ring stem seal virtually eliminates hard to turn handles frequently encountered with packed type seals.
- Heavy duty rolled ACME stem threads provide quick action and long service life.

## Materials

Body ..... Ductile Iron  
 Bonnet (7034, 7505-7508)..... Steel  
 Bonnet (7509-7518)..... Ductile Iron  
 Valve Stem ..... Stainless Steel  
 Wiper Ring..... Synthetic Rubber  
 Seat Disc..... See Ordering Chart  
 "V"-Rings ..... Teflon  
 Handwheel..... Ductile Iron  
 Spring ..... Stainless Steel



**A7518FP**



**TA7034**



**A7505AP**



**A7514AP**



**A7513AP**



**A7517AP**



**A7517FP**

## Ordering Information

Part Number				Inlet and Outlet Connection	Port Diameter	Flow at 1 PSIG Pressure Drop (Cv) (GPM/Propane)***		Accessories	
Buna N Seat Discs		Teflon Seat Discs*				Globe	Angle	Hydrostatic Relief Valve	Vent Valve
Globe	Angle	Globe	Angle						
-	-	TA7034P	TA7034LP	½" F. NPT	¾"	10.0	14.8	SS8001U	TSS3169
A7505AP	A7506AP	TA7505AP	TA7506AP	¾" F. NPT	1"	12.0	17.7		
A7507AP	A7508AP	TA7507AP	-	1" F. NPT	1¼"	17.8	22.0		
A7509BP	A7510BP	TA7509BP	TA7510BP	1¼" F. NPT	1½"	36.5	54.0		
A7511AP	A7512AP	TA7511AP	TA7512AP	1½" F. NPT	2"	43.0	55.5		
A7511FP	-	TA7511FP	-	1½" Flange**		46.0	-		
A7513AP	A7514AP	TA7513AP	-	2" F. NPT	75.0	88.5			
A7513FP	A7514FP	TA7513FP	TA7514FP	2" Flange**	78.0	133.0			
A7517AP	A7518AP	TA7517AP	-	3" F. NPT	3½"	197.0	303.0		
A7517FP	A7518FP	TA7517FP	-	3" Flange**					

\* Teflon seat discs on valves built to order.

\*\* 300# ANSI R.F. Flange.

\*\*\* To obtain approximate flow at other than 1 PSIG pressure drop, multiply flow in chart by square root of pressure drop. Example: 7514FP @ 9 PSIG = 133 x 9 = 399 GPM/propane. For NH<sub>3</sub> flow, multiple propane flow by .90.

# Globe and Angle Valve Dimensions

Drawing	Valve Number (A or TA Prefix)	Inlet & Outlet	Port Diameter	Dimensions						
				A	B	C	Flanges			G
							D	E	F	
	7034P	1/2" F. NPT	3/4"	4 3/4"	-	3 1/16"	-	-	-	-
	7505AP	3/4" F. NPT				4 5/16"				
	7507AP	1" F. NPT	1"							
	7034LP	1/2" F. NPT	3/4"	4 3/4"	1 3/4"	-	-	-	-	-
	7506AP	3/4" F. NPT			2"					
	7508AP	1" F. NPT	1"							
	7509BP	1 1/4" F. NPT	1 1/4"	7 41/64"	-	4 7/8"	-	-	-	-
	7511AP	1 1/2" F. NPT	1 1/2"	6 3/4"		5 3/16"				
	7513AP	2" F. NPT	2"	7 7/16"		5 7/8"				
	7517AP	3" F. NPT	3 3/8"	13 1/4"		9"				
	7510BP	1 1/4" F. NPT	1 1/4"	6 3/4"	2 1/4"	-	-	-	-	5 1/4"
	7512AP	1 1/2" F. NPT	1 1/2"	6 13/16"	2 7/16"					
	7514AP	2" F. NPT	2"	7 7/16"	2 11/16"					
	7518AP	3" F. NPT	3 3/8"	11 3/4"	4"					
	7511FP	1 1/2" Flange	1 1/2"	7 9/16"	-	7 1/2"	6 1/8"	3/4"	2 7/8"	5 1/4"
	7513FP	2" Flange	2"	8 7/16"		8 1/2"	6 1/2"	1 3/16"	3 5/8"	
	7517FP	3" Flange	3 3/8"	13 1/4"		11 1/8"	8 1/4"	1 1/8"	5"	
	7514FP	2" Flange	2"	7 1/2"	5 1/4"	-	6 1/2"	1 3/16"	3 5/8"	5 1/4"
	7518FP	3" Flange	3 3/8"	11 1/4"	6 1/4"		8 1/4"	1 1/8"	5"	9"

NOTE: Regarding 7505AP through 7510BP — the thread used for assembling the bonnet to the body of the valve is a left hand thread. We advise our customers to be cognizant of this assembly design in attempting to remove the bonnets of these valves in order to avoid serious damage to the valves.

## Flange Dimensions

Valve Number (A or TA Prefix)	Size	Flange Drilling	D	E	F	H
7511FP	1 1/2"	7/8" Bolt Holes on a 4 1/2" Bolt Circle Diameter	6 1/8"	1 3/16"	2 7/8"	3/4"
7513FP	2"	3/4" Bolt Holes on a 5" Bolt Circle Diameter	6 1/2"	7/8"	3 5/8"	1 3/16"
7514FP						
7517FP	3"*	7/8" Bolt Holes on a 6 5/8" Bolt Circle Diameter	8 1/4"	1 1/8"	5"	1 1/8"
7518FP						

\* Reducing screwed flanges are available for reducing 1 1/2" flange to 1 or 1 1/4" pipe thread and 3" flange to 2 1/2" pipe thread. Order from your local piping supplier.

# 2" & 3" Globe/Angle valves with Built-in Automatic Back Check HA7513AP/HA7514AP and HA7517AP/HA7518AP

## Application

Designed for use in conjunction with our 6588LE and 6589LE low emission filler valves installed on bobtails and transports. The valves are designed to stop flow out of the container when the hand-wheel is closed. They incorporate an automatic integral back check that is designed to allow flow back into the container to prevent liquid from becoming trapped between the 6588/89LE and the closed globe/angle valve.

## Features

- V-ring spring loaded pressure stem seal provides for leak-proof operation. No packing to retighten or replace.
- Circular bridge in globe design and a dropped seat in the angle design achieve greater flow with less pressure drop.
- Swivel seat disc assembly minimizes wear which provides for good alignment and long seat life.
- ¼" F.NPT plugged holes on upstream and downstream sides of the valve.
- Heavy duty rolled ACME stem threads provide quick action and long service life.
- Seat Disc assembly incorporates an automatic back check valve, eliminating the need for a separate hydrostatic relief valve.

## Materials

Body ..... Ductile Iron  
 Stem ..... Stainless Steel  
 Seat ..... Stainless Steel  
 Seat Disc ..... Synthetic Rubber  
 Return Spring ..... Stainless Steel



**HA7513AP**



**HA7514AP**

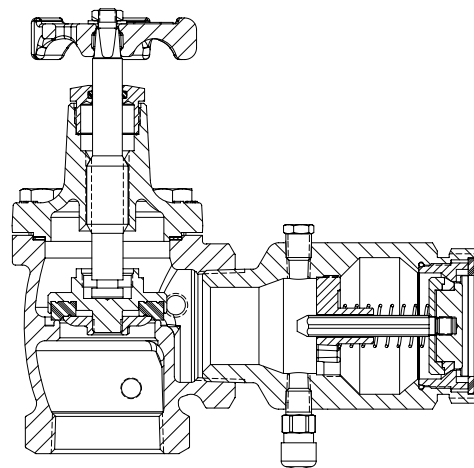

## Ordering Information

Part Number		Inlet/Outlet Connection	Port Diameter	Flow at 1 PSIG Pressure drop GPM Propane	
Globe	Angle			Globe	Angle
HA7513AP	HA7514AP	2" -FNPT	2"	75.0	88.5
HA7517AP	HA7518AP	3"-FNPT	3½"	197.0	303.0

# Flange Seal Globe and Angle Valve Information

## General Information

Globe and Angle Valves, incorporating the synthetic rubber flange seal design, operate on the same principle as the "V"-ring valves. Gas pressure in the valve is exerted against the synthetic rubber flange, forcing it tightly against the stem.

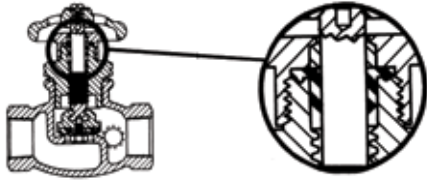

Leak-tight performance is assured and periodic adjustment is not required. The synthetic rubber construction provides smooth operating performance with long service life.

These valves all incorporate a plugged 1/4" NPT side boss on the downstream side of the valve that can be equipped with a hydrostatic relief valve or vent valve.

Please be familiar with the "Installation and Operation Note" and "Downstream Accessory Boss" section of the "V"-ring valve design general information before ordering these valves.

## General Features

Rugged quick-acting ACME threads on stem. Threads are under flange ring . . . dust, sand and grit can't reach them.

Swivel seat cannot grind during valve opening or closing.

Synthetic Rubber Seat Disc

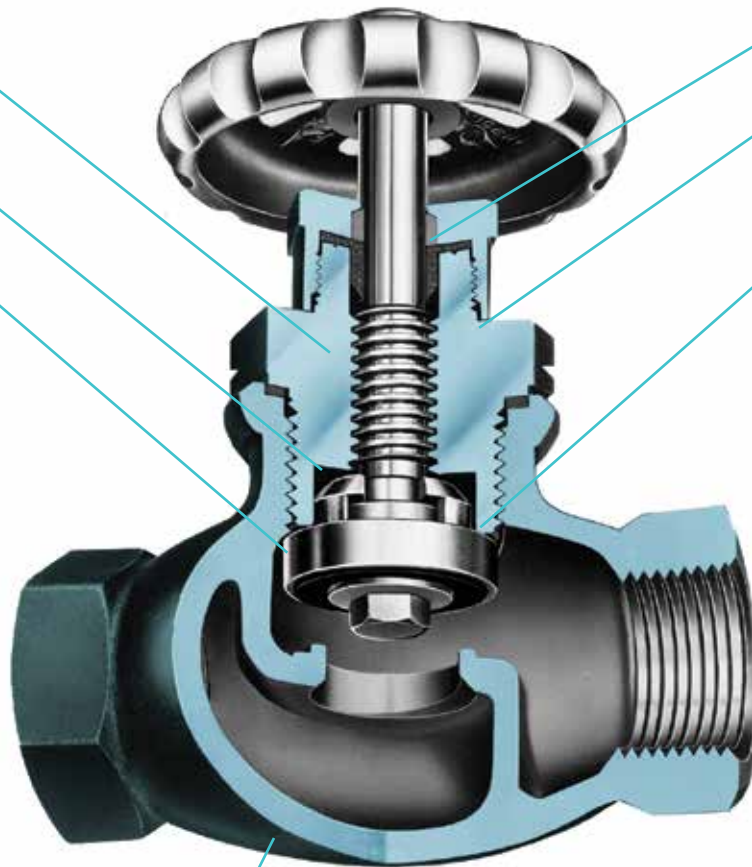

Nylon bearing surrounds stem to prevent galling.

Rubber flange ring stem seal effectively prevents gas escape. The higher the pressure, the tighter the seal.

Metal to metal back seat permits replacement of flange ring with valve in service.

Valve body made of shell molded ductile iron. Highly resistant to cracking or fracturing from wrenching, dropping or hammer blows. Bonnet and seal cap are steel on "A" prefix valves.

# Flange Seal Globe and Angle Valves for Bulk Storage Containers, Filling Hoses and Plant Piping 7704, 7705 and 7706 Series

## Application

Designed to ensure positive shut-off and long maintenance-free service life in liquid or vapor service. Ideally suited for use on cylinder charging manifolds, truck filling hoses, bulk storage containers and plant piping.

The high quality construction and wide variety of sizes make them highly suited for use with LP-Gas, anhydrous ammonia and in the chemical and petrochemical industries.

## Features

- Available with either a brass bonnet and bronze stem for LP-Gas service or a steel bonnet and stainless steel stem for combined LP-Gas and anhydrous ammonia service.
- Flange seal stem provides for leak-proof operation. No packing to retighten or replace.
- Metal-to-metal back seat permits replacement of the flange ring with the valve in service.
- Plugged 1/4" NPT boss on downstream side of valve accommodates hydrostatic relief valve or vent valve.
- Swivel seat disc minimizes grinding on the body seat and ensures longer service life.
- "Dropped seat" body design of the angle valve provides high flow capacity.

## Materials

Body .....	Ductile Iron
Bonnet (7704, 05, 06) .....	Brass
Bonnet (A7704, 05, 06) .....	Steel
Stem (7704-05-06) .....	Bronze
Stem (A7704-05-06) .....	Stainless Steel
Flange Ring .....	Synthetic Rubber
Seat Disc .....	Synthetic Rubber



**A7704P**

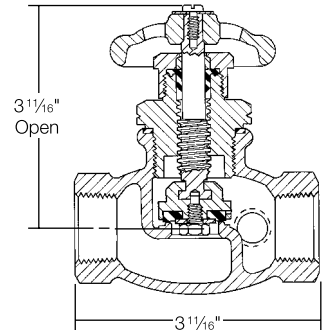

**7704 P  
A7704 P  
7705 P  
A7705 P**



**7706P**

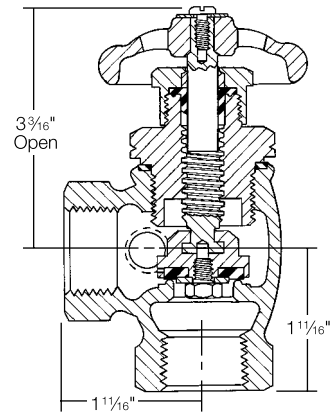

**7704 LP  
A7704 LP  
7706 P  
A7706 P**



## Ordering Information

Part Number		Inlet & Outlet Connection (F. NPT)	Flow at 1 PSIG Pressure Drop (Cv) (GPM/Propane)*		Accessories	
Globe	Angle		Globe	Angle	Hydrostatic Relief Valve	Vent Valve
7704P	7704LP	1/2"	7.3	12.3	SS8001J or SS8001L	TSS3169
A7704P	A7704LP					
7705P	7706P	3/4"	11.5	17.7		
A7705P	A7706P					

\* To obtain approximate flow at other than 1 PSIG pressure drop, multiply flow in table by square root of pressure drop. Example: A7704LP @ 9 PSIG = 12.3 x  $\sqrt{9}$  = 36.9 GPM/propane. For NH<sub>3</sub> flow, multiply propane flow by .90.



# Flange Seal Liquid Transfer Angle Valves for Bulk Storage Containers 7550 and 7551 Series

## Application

Designed especially for liquid transfer of LP-Gas from consumer bulk storage containers when used with a Chek-Lok® or equipped with an integral excess flow valve. May also be used for vapor LP-Gas service.

In NH<sub>3</sub> applicator tanks they may be used as a vapor bleeder valve or as a liquid withdrawal valve when installed in a coupling with a dip pipe.

These liquid transfer valves are equipped with an integral excess flow valve for liquid transfer directly from the tank fitting, or without an integral excess flow for LP-Gas transfer through a Check-Lok®.

When equipped with an integral excess flow valve (7550PX), the valve should be mounted in a forged steel 3000 lb. half coupling. When mounted in a 1 1/4" x 3/4" NPT reducing coupling, the 3/4" female thread in this coupling must be full length — equivalent to a forged steel 3000 lb. half coupling.

The excess flow valve will not function properly if these specifications are not met. Refer to the Warning Bulletin in the Excess Flow Valve Section of this catalog.

## Features

- Flange seal stem design provides for leak-proof operation. No packing to retighten or replace.
- Large, unrestricted interior ports reduce pressure drop through the valve, increasing capacity and preventing cavitation.
- Resilient swivel seat disc ensures longer seat life and easy, positive shut-off.
- Plugged 1/4" NPT outlet boss accommodates hydrostatic relief valve or vent valve.
- Specifically designed for liquid transfer of LP-Gas with the Chek-Lok®.

## Materials

Body (7550, 51).....	Brass
Body (A7550, 51).....	Cadmium Plated Ductile Iron
Bonnet (7550, 51).....	Brass
Bonnet (A7550, 51).....	Steel
Stem (7550, 51).....	Bronze
Stem (A7550, 51).....	Stainless Steel
Flange Ring.....	Synthetic Rubber
Seat Disc.....	Synthetic Rubber



7550P



7550PX

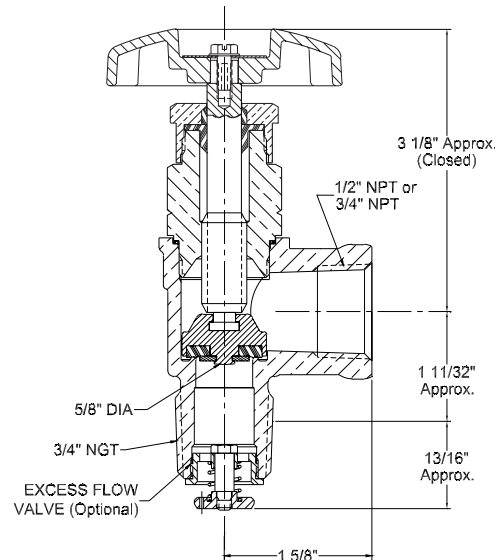

## Ordering Information

Part Number	Inlet Connection (M. NPT)	Outlet Connection (F. NPT)	Integral Excess Flow	Flow at 1 PSIG (Cv) Pressure Drop* (GPM/Propane)	Excess Flow Approximate Closing Flow** (GPM/Propane)	Accessories	
						Hydrostatic Relief Valve	Vent Valve
7550P	3/4"	3/4"	No	13.3	-	3127U	3165
A7550P					SS8001J	TSS3169	
7550PX		1/2"	Yes	-	16.0	3127U	3165
A7550PX					SS8001J	TSS3169	
7551P			No	8.9	-	3127U	3165
A7551P						SS8001J	TSS3169

\* To obtain approximate flow at other than 1 PSIG pressure drop, multiply flow in table by square root of pressure drop. Example: 7550P @ 9 PSIG = 13.3 x √9 = 39.9 GPM/propane. For NH<sub>3</sub> flow, multiple propane flow by .90.

\*\* For NH<sub>3</sub> flow, multiply propane flow by .90.

# Tank Car Angle Valves for Railroad Tank Cars TA7894P

## Application

Designed especially for transfer of LP-Gas and anhydrous ammonia in railroad tank car service.

The combined heavyweight ductile iron castings and precision machining provide ruggedness and superior performance in working pressures up to 400 PSIG.

## Features

- "V"-ring spring-loaded pressure seal design provides dependable, leak-free operation. No packing to retighten or replace.
- Wiper o-ring eliminates entrance of dirt and grit into stem area that can prohibit smooth operation.
- Heavy duty ACME stem threads give quick action and are hardened for long service life.
- Swivel seat reduces scoring of seat disc and provides positive shut-off.
- Full diameter seat provides greater flow capacity and low pressure drop.
- Plugged 1/4" NPT boss on downstream side of valve accommodates vent valve or hydrostatic relief valve.
- Equipped with a malleable iron plug and chain installed in the valve outlet.



**AAR Approval #E-149515**



**TA7894P**

## Materials

Body .....	Ductile Iron
"V"-Rings .....	Teflon
O-Ring .....	Synthetic Rubber
Stem .....	Stainless Steel
Bonnet .....	Ductile Iron
Seat Disc .....	Teflon
Handwheel.....	Cadmium Plated Ductile Iron

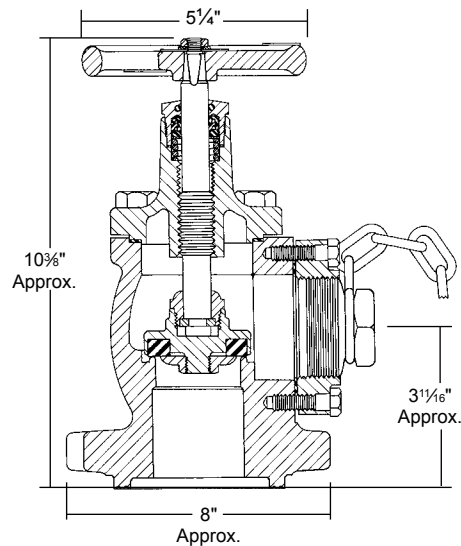

## Ordering Information

Part Number	Inlet Connection	Outlet Connection (F.NPT)	Flow At 1 PSIG (Cv) Pressure Drop	Accessories	
				Hydrostatic Relief Valve	Vent Valve
<b>TA7894P</b>	Tank Car Flange	2"	112	SS8001U	TSS3169

\* To obtain approximate flow at other than 1 PSIG pressure drop, multiply flow in table by square root of pressure drop. Example: TA7894P @ 9 PSIG = 112 x  $\sqrt{9}$  = 336 GPM/propane. For NH<sub>3</sub> flow, multiply propane flow by .90.

# High Capacity Liquid Withdrawal Valves For NH3 A8012 Series

## Application

The A8012 Series is designed especially for use as a high capacity liquid withdrawal valve on anhydrous ammonia nurse tanks or risers.

This valve incorporates an integral excess flow valve; when the valve is in operation the handwheel must be completely open and back-seated to allow the excess flow valve to function properly as explained in the excess flow section of our L-500 and L-102 catalogs.

## Features

- Excess flow valve designed for high flow and low pressure drop.
- Excess flow seat fully contained in the container coupling for maximum protection in the event of external damage to the valve.
- Resilient disc assembly with swivel seat is fully contained for bubble-tight shut-off and long service life.
- "V"- ring spring loaded stem seal design requires no field adjustment.
- ¼" F.NPT port that accommodates a vent valve or hydrostatic relief valve.
- UL Listed for LP-Gas and anhydrous ammonia.

## Materials

Body .....	Ductile Iron
Bonnet .....	Ductile Iron
Stem .....	Stainless Steel
Seat Disc .....	Nitrile
"V" -Rings.....	Teflon
Excess Flow Valve.....	Stainless Steel
Springs .....	Stainless Steel



**A8012D**

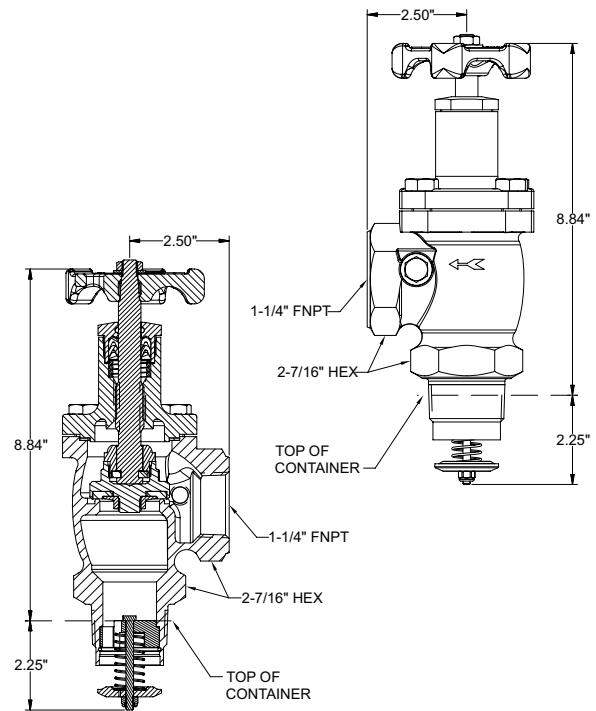

## Ordering Information

Part Number	Inlet Connection	Outlet Connection	Approximate Closing Flow GPM	Accessories for NH3 Use	
				Hydrostatic Relief Valve	Vent Valve
A8012D	1½" M.NPT	1¼" F.NPT	72 GPM NH3*	SS8001J	TSS3169
A8012C			45 GPM NH3*		

\* When installed in a horizontally flowing system.

# Multipurpose Valve for Filling of NH3 Containers A8016DBC

## Application

Designed specifically for use as a manual filler valve on anhydrous ammonia applicator tanks. This valve incorporates an integral back check valve.



## Features

- Positive seating back check valve opens for maximum flow at minimum pressure drop when filling — regardless of the type of coupling in which the valve is installed.
- Back Check seat is fully contained in the tank coupling for maximum protection in the event of external damage to the valve.
- Resilient seat disc assembly is fully contained on three sides for bubble-tight shut-off and long service life.
- “V”-ring spring-loaded stem seal design requires no repacking or field adjustment.
- Specially machined break-away groove beneath ACME threads will shear-off with excessive pull on the hose and leave the valve body intact.
- Plugged 1/4" NPT boss accommodates vent valve or hydrostatic relief valve.



**A8016DBC**

## Materials

Body .....	Ductile Iron
Bonnet .....	Steel
“V”-Rings .....	Teflon
Stem .....	Stainless Steel
Seat Disc .....	Resilient Synthetic Rubber
Back Check Valve.....	Stainless Steel, Steel and Synthetic Rubber
Springs .....	Stainless Steel

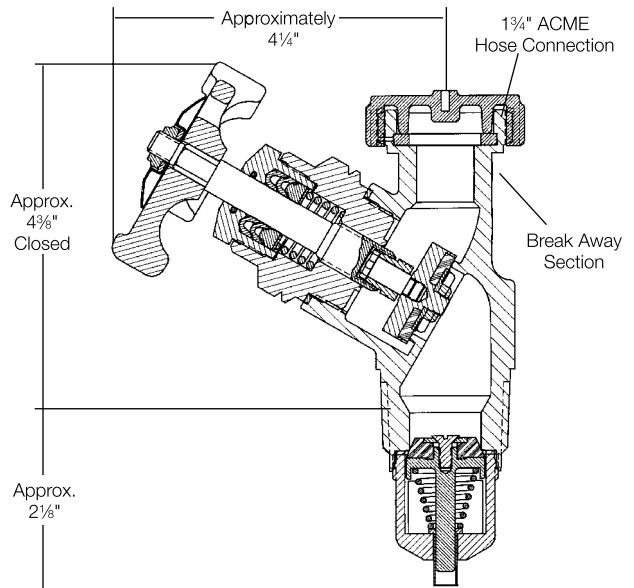

## Ordering Information

Part Number	Inlet Connection	Filling Connection	Filling Capacity at 20 PSIG Pressure Drop GPM/NH <sub>3</sub>	Accessories	
				Hydrostatic Relief Valve	Vent Valve
A8016DBC	1 1/4"	1 1/4"	95	SS8001J	TSS3169

# Multipurpose Valve for Filling of NH3 Containers A8016DP

## Application

Designed specifically for use as a manual valve or vapor equalizing valve on anhydrous ammonia applicator and nurse tanks.

This valve incorporates an integral excess flow valve. When product is required, the valve must be completely open and backseated to allow the excess flow valve to function properly as explained in the excess flow section of this catalog.

## Features

- Positive-acting excess flow valve opens for maximum flow at minimum pressure drop when filling -- regardless of the type of coupling in which the valve is installed.
- Excess flow seat is fully contained in the tank coupling for maximum protection in the event of external damage to the valve.
- Resilient seat disc assembly is fully contained on three sides for bubble-tight shut-off and long service life.
- "V"-ring spring-loaded stem seal design requires no repacking or field adjustment.
- Specially machined break-away groove beneath ACME threads will shear-off with excessive pull on the hose and leave the valve body intact.
- Plugged 1/4" NPT boss accommodates vent valve or hydrostatic relief valve.



**A8016DP**

## Materials

Body .....	Ductile Iron
Bonnet .....	Steel
"V"-Rings .....	Teflon
Stem .....	Stainless Steel
Seat Disc .....	Resilient Synthetic Rubber
Excess Flow Valve .....	Stainless Steel--Steel Body
Springs .....	Stainless Steel

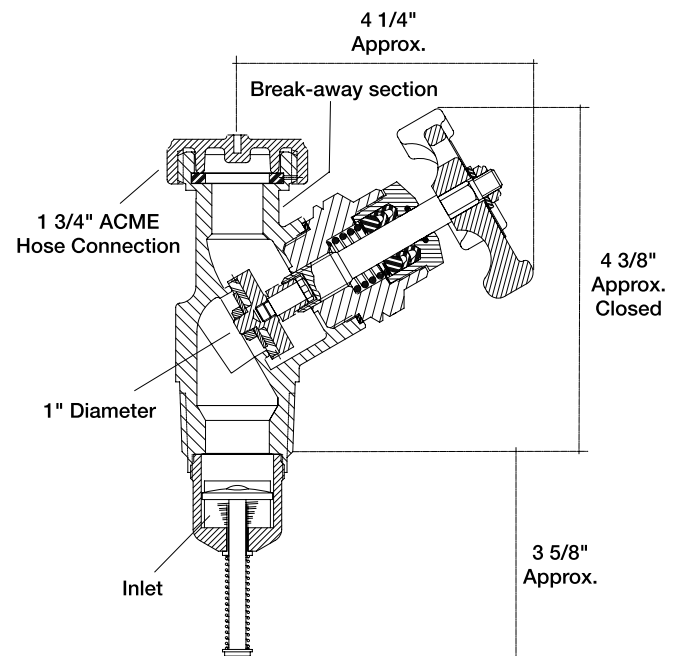

## Ordering Information

Part Number	Inlet Connection (M. NPT)	Filling Connection (M. ACME)	Filling Capacity At 20 PSIG Pressure Drop GPM/NH3*	Approximate Excess Flow Closing Flows		Accessories	
				Liquid* GPM/NH3	Vapor** CFH/NH3	Hydrostatic Relief Valve	Vent Valve
<b>A8016DP</b>	1 1/4"	1 3/4"	95	44	24,000	SS8001J	TSS3169

\* Determined at 9.5 to 12 PSIG differential.

\*\* Determined at 100 PSIG inlet.

# Multipurpose Valves for Liquid Withdrawal of LP-Gas and NH<sub>3</sub> Containers

## A8017D & A8020D

### Application

Designed especially for use as a high capacity liquid withdrawal valve on LP-Gas and anhydrous ammonia containers.

These valves incorporate an integral excess flow valve. When product is required, the valve must be completely open and backseated to allow the excess flow valve to function properly as explained in the excess flow valve section of this catalog.

The A8017DH is equipped with a soft seated automatic differential back pressure check valve in the seat disc assembly. This allows any pressure build up in the liquid transfer line in excess of 10-15 psig above the container pressure to flow back into the container. The transfer hose is protected against excessive liquid or vapor pressure entrapment, which adds materially to the useful life of flexible hose. In addition to increasing hose service life, the equalizing valve adds substantially to the operating safety of liquid transfer systems.

### Features

- Positive-acting excess flow valve opens for maximum flow at minimum pressure drop when filling — regardless of the type of coupling in which the valve is installed.
- Excess flow seat is fully contained in the tank coupling for maximum protection in the event of external damage to the valve.
- Resilient seat disc assembly is fully contained on three sides for bubble-tight shut-off and long service life.
- "V"-ring spring loaded stem seal design requires no repacking or field adjustment.
- A8017DH has two plugged ¼" NPT ports, one on the top and the other on the side, accommodate either a vent valve or hydrostatic relief valve.
- A8020D has a plugged ¼" NPT port that accommodates vent valve, hydrostatic relief valve, or pressure gauge.
- A8017DH incorporates an automatic back check valve built into the shut-off valve, eliminating the need for a separate hydrostatic relief valve.

### Materials

Body ..... Ductile Iron  
 Bonnet ..... Steel  
 Stem ..... Stainless Steel  
 Seat Disc ..... Resilient Synthetic Rubber  
 "V"-Rings ..... Teflon  
 Excess Flow Valve ..... Stainless Steel - Steel Body Springs  
 Springs ..... Stainless Steel

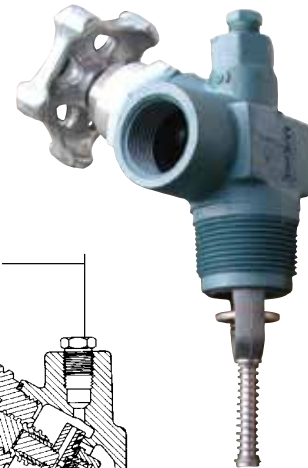

**A8017DP**

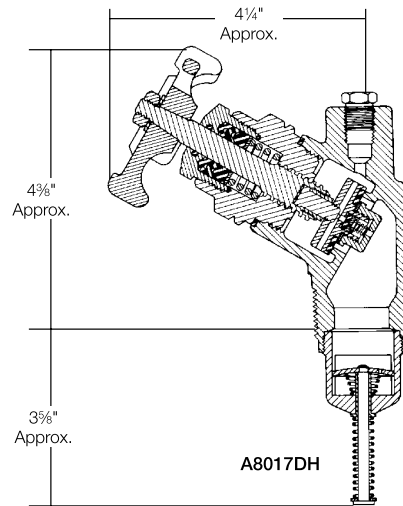

**A8017DH**

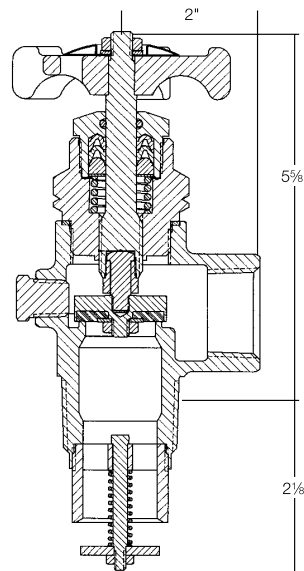

**A8020D**



### Ordering Information

Part Number	Inlet Connection (M. NPT)	Outlet Connection (F. NPT)	Approximate Excess Flow Liquid Closing Flow** (GPM/Propane)	Accessories	
				Hydrostatic Relief Valve	Vent Valve
A8017DH*	1 1/4"	1"	49	Not Required	TSS3169
A8017DP			55		
A8017DLP	1 1/4"	1"	49	SS8001J	TSS3169
A8020D			78	SS8001J	TSS3169

\* Built-in back pressure check valve incorporated into shut-off valve.

\*\* Determined at 11.5 to 13.5 PSIG differential for 3/4" outlet and 9 to 12 PSIG differential for 1" outlet. For NH<sub>3</sub> flow, multiply by .90.

# Multipurpose Valve for Filling and Liquid Transfer of NH<sub>3</sub> Containers A8018DP

## Application

Designed primarily for use as a combination filler and liquid withdrawal valve on three-opening applicator tanks or on nurse tanks.

This valve incorporates an integral excess flow valve. When product is required, the valve must be completely open and backseated to allow the excess flow valve to function properly as explained in the excess flow valve section of this catalog.

## Features

- Functions as both a filler valve and liquid transfer valve, in one unit.
- Positive acting excess flow valve opens for maximum flow at minimum pressure drop when filling — regardless of the type of coupling in which the valve is installed.
- Excess flow seat is fully contained in the tank coupling for maximum protection in the event of external damage to the valve.
- Specially machined break-away groove beneath ACME thread of filler valve will shear-off with excessive pull on the hose and leave the valve body intact.
- Triple guide filler valve check provides for dependable shut-off performance when filling ceases.
- Resilient seat disc assembly is fully contained on three sides for bubble-tight shut-off and long service life.
- "V"-ring spring loaded stem seal design requires no repacking or field adjustment.
- Plugged 1/4" NPT boss accommodates vent valve or hydrostatic relief valve.

## Materials

Body .....	Ductile Iron
Bonnet .....	Steel
Stem .....	Stainless Steel
Seat Discs .....	Synthetic Resilient Rubber
"V"-Rings .....	Teflon
Excess Flow Valve .....	Stainless Steel - Steel Body
Springs .....	Stainless Steel



**A8018DP**

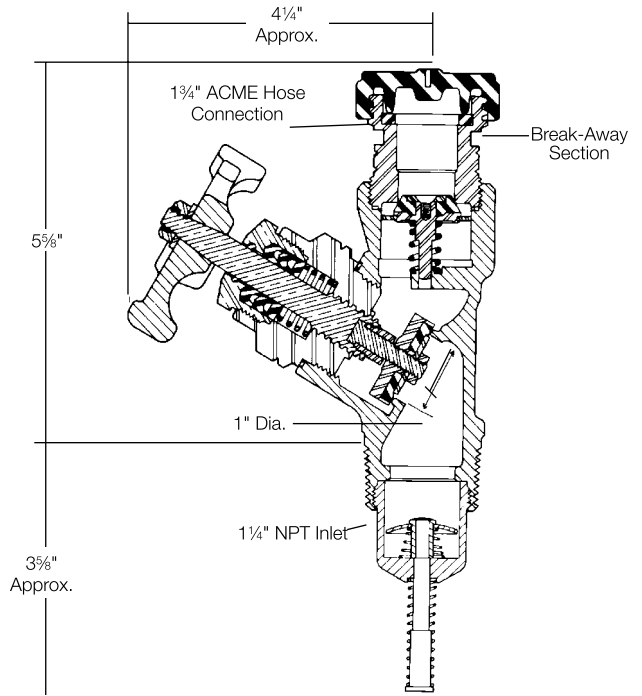

## Ordering Information

Part Number	Inlet Connection (M. NPT)	Outlet Connection (F. NPT)	Filling Connection (M.ACME)	Filling Capacity At 20 PSIG Pressure Drop GPM/NH <sub>3</sub>	Approximate Excess Flow Liquid Closing Flow GPM/NH <sub>3</sub>	Accessories	
						Hydrostatic Relief Valve	Vent Valve
<b>A8018DP</b>	1 1/4"	1"	1 1/4"	74	50	SS8001J	TSS3169

\* Determined at 9 to 12 PSIG differential.

# Multipurpose Filler Valves

## 8118P and 8117

### Application

Designed primarily for use as a Multipurpose valve with combination filler valve and manual shutoff valve for the outlet connection of the valve for use on LP-Gas containers.

This valve incorporates an integral excess flow valve. When product is required, the valve must be completely open and back seated to allow the excess flow valve to function properly as explained in the excess flow valve section of the RegO L-102 or L-500 catalogs.

### Features

- Designed as a filler valve for LP-Gas with upper check and manual shutoff.
- Excess flow valve allows for maximum filling rates regardless of the length of the coupling the valve is installed in.
- Excess flow seat is fully contained in the tank coupling for maximum protection in the event of external damage to the valve.
- Breakaway groove protects the ACME in the case of a drive-away with the filler hose still connected.
- V-ring spring loaded stem assembly requires no repacking of field adjustment.
- Plugged ¼" NPT boss allows for a pressure gauge to be installed.
- The one-inch outlet port plugged.



**8118P**

### Materials

Body .....	Brass
Inlet Connection.....	Brass
Outlet Connection.....	Brass
Spring .....	Stainless Steel
Seat Disc .....	Synthetic Rubber
V-rings .....	Teflon
Excess Flow Valve.....	Stainless Steel

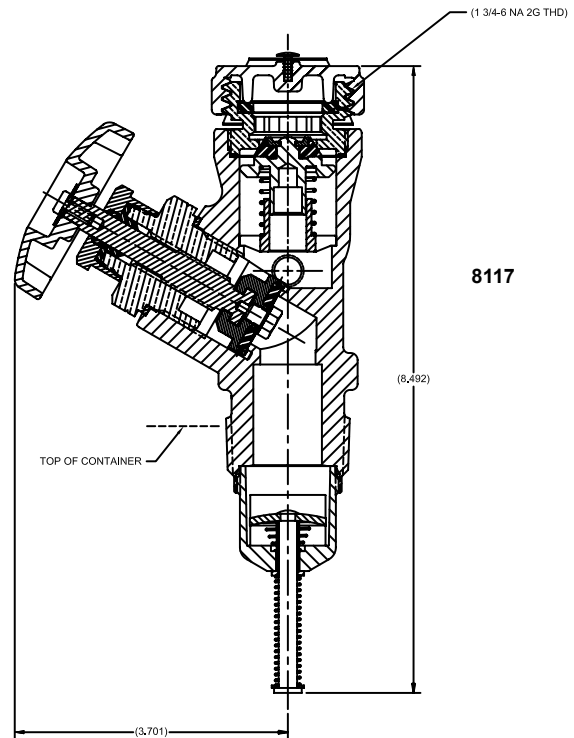

**8117**



### Ordering Information

Part Number	Container Connection	Outlet Connection	Filler Connection	Plug	Filling Capacity at 20 PSIG Pressure Drop
8117	1 ¼" M.NPT	¾" F. NPT	1 ¼" M.ACME	No	82 GPM
8118P		1" F. NPT		Yes	



# Adhesive Warning Labels

## 903-500

The following warning information, Part Number 903-500, is included with each shipment of Quick-Acting and Tank Car Valves to the first purchaser of the product from the factory.

This information is intended to be forwarded throughout the product distribution chain. Additional copies are available from RegO and Authorized Product Distributors.

Part Number	
903-500	Adhesive Warning Label

<b>DANGER</b>	<b>READ THIS FIRST</b>	<b>WARNING</b>
<b>LP-GAS IS EXTREMELY FLAMMABLE AND EXPLOSIVE</b>		
<p><b>AVOID SERIOUS INJURY AND PROPERTY DAMAGE. IF YOU SEE, SMELL OR HEAR ESCAPING GAS...EVACUATE AREA IMMEDIATELY! CALL YOUR LOCAL FIRE DEPARTMENT! DO NOT ATTEMPT TO REPAIR. DO NOT STORE IN BUILDING OR ENCLOSED AREA. DO NOT USE ON HOT AIR BALLOONS OR AIRCRAFT.</b></p> <p>Make sure you are thoroughly trained before you attempt any valve installation, maintenance or repair. Improper conditions or procedures can cause accidents resulting in property damage and personal injury.</p> <p>Become thoroughly familiar with NPGA Safety Pamphlet 306 "LP-Gas Regulator and Valve Inspections &amp; Maintenance" and RegO Safety Warnings "LP-Gas Cylinder Valves", "LP-Gas Excess Flow Valves", and "LP-Gas Filler and Hose End Filling Valves" found in the cylinder valve, excess flow valve, and filler valve sections of the L-500 &amp; L-102 Catalogs. Follow their recommendations.</p> <p>Know and understand NFPA Pamphlet 58 "Liquefied Petroleum Gas Code", which is the law in many states. This publication is available from NFPA, Batterymarch Park, Quincy, MA 02269. Following its requirements is essential in the safe use of LP-Gas. Section 4.4 states: "Persons who transfer liquid LP-Gas, who are employed to transport LP-Gas, or whose primary duties fall within the scope of this code shall be trained in proper handling procedures. Refresher training shall be provided at least every three years and shall be documented."</p> <p>Make sure this valve is the proper one for this installation. Avoid misusing LP-Gas equipment.</p> <p>Apply thread joint compound compatible with LP-Gas on valve external threads only. Make sure compound never comes into contact with other parts of the valve.</p> <p>Install valves by applying force to wrenching flats only.</p> <p>Tighten pipe threads approximately 1 to 1½ turns beyond the hand-tight insertion point using a wrench which avoids damage to other valve parts.</p> <p>Check for damage and proper operation after valve installation. Check that the valve is clean and free of foreign material.</p> <p>Check container-valve connection with a non-corrosive leak detection solution before filling with LP-Gas.</p> <p>Purge container before filling with LP-Gas (refer to the RegO LP-Gas Serviceman's Manual for recommended procedure).</p> <p>Test excess flow check valve for proper operation before placing into service. See NPGA Bulletin 113 for recommended procedure.</p> <p>Check outlet connection make-up for leaks with a non-corrosive leak detection solution when placing into service.</p> <p><b>RegO Filler Valves:</b> To prevent damage to the internal checks when it is necessary to utilize an unloading adapter, use ONLY RegO 3119A, 3120 and 3121 Unloading Adapters with RegO Filler Valves. Carefully follow the instructions supplied with these unloading adapters.</p> <p>If container is not being placed into service at the present time, insert plug or cap onto the outlet connection.</p> <p>In selecting a label for posting at the installation site, consider RegO part number 901-400 or 903-400 along with your own, NPGAs and others.</p> <p>Remember to instruct the owner/user/customer in safety matters concerning LP-Gas and this equipment. See RegO Safety Warnings "LP-Gas Cylinder Valves", "LP-Gas Excess Flow Valves", and "LP-Gas Filler and Hose End Filling Valves" found in the cylinder valve, excess flow valve, and filler valve sections of the L-500 &amp; L-102 Catalogs.</p>		
<p>RegO requests that this information be forwarded to your customers. Additional copies are available from RegO and your authorized RegO Distributor.</p>		
		<p>Printed in USA 09A-0910-0686 Part number 903-500</p>
<p>Elon, N.C. 27244 U.S.A. Phone (336) 449-7707 Fax (336) 449-6594 <a href="http://www.regoproducts.com">www.regoproducts.com</a></p>		

**903-500**

