



L-500 Catalog

LP-Gas & Anhydrous Ammonia Equipment

Application Illustrations **1**

Regulators & Accessories **A**

Cylinder & Service Valves **B**

Multivalve® Assemblies **C**

Pressure Relief Valves & Relief Valve Manifolds **D**

Globe & Angle Valves **E**

Excess Flow, Check, Filler & Pressure Vapor Equalizing Valves **F**

Internal Valves & Accessories **G**

Adapters, Connectors & Fittings **H**

Miscellaneous Equipment (Including Rotogages & ESVs) **J**

Foreword

This catalog describes a complete line of equipment available from RegO® for use with Liquid Propane (LP)-Gas and anhydrous ammonia (NH₃). The following points are important to know for proper use of the catalog:

1. Illustrations and drawings of individual products are representative of "product groups" and all products within a product group are similar in construction.
2. Materials used for construction of products in this catalog are suitable for rated service pressure at temperatures of -40°F to +165°F, unless otherwise specified.
3. Products in this catalog are only intended for use in LP-Gas and/or anhydrous ammonia service as follows.
 - a. "A" or "AA" prefix — Products with this prefix are suitable for NH₃ service (i.e., contain no brass parts).
 - b. "AA" prefix on relief valves — These valves are NOT suitable for use with LP-Gas service. These are of partial aluminum materials and are listed by Underwriters Laboratories (UL) for NH₃ service only.
 - c. All other products including "A" prefix are suitable for use with LP-Gas & NH₃ service.
 - d. "SS" prefix—Hydrostatic relief valve with this prefix are suitable for NH₃ and LP-Gas service (i.e., they have stainless steel materials).
4. We manufacture valves and adapters designed to be used on LP-Gas and Anhydrous Ammonia systems, we do not design systems or consult in system design. For this type of information consult a professional Engineer.

Caution

Do not use any product contained in this catalog with any service commodity other than LP-Gas or NH₃. If you have a need for use of another application, contact RegO, 100 RegO Drive, Elon, NC 27244, (336) 449-7707 ecii@regoproducts.com before proceeding.

Proper application, installation and maintenance of products in this catalog are essential. Users of these products should obtain further information if there are any doubts or questions.

Warning

All RegO products are mechanical devices that will eventually become inoperative due to wear, corrosion and aging of components made of materials such as rubber. The environment and conditions of use will determine the safe service life of these products. Periodic inspection and maintenance are essential to avoid serious injury and property damage.

Many RegO products are manufactured for storage, transport, transfer and use of toxic flammable and dangerous liquids and gases. Such substances should be handled by experienced and trained personnel only, using accepted governmental and industrial safety procedures. Never vent LP-Gas near any possible source of ignition.

Notice

Installation, usage, and maintenance of all RegO products must be in compliance with all RegO instructions as well as requirements and provisions of NFPA #54, NFPA#58, DOT, ANSI, and all applicable federal, state, provincial and local standards, codes, regulations, and laws.

Inspection and maintenance on a periodic basis is essential. Installation and maintenance should be performed only by qualified personnel.

Be sure all instructions are read and understood before installation, operation and service.

Filters

RegO LP-Gas equipment is designed to operate in a system free from contamination. A variety of in-line filters are commercially available to the LP-Gas industry for installation in domestic systems.

The use of an in-line filter should be considered when other system components may be unclean and the system contaminated by rust, scale, dirt, debris or other foreign material.

Determining the Age of Products

All RegO products are mechanical devices that will eventually become inoperative due to wear, contaminants, corrosion and aging of components made of material such as metal and rubber.

The environment and conditions of use will determine the safe service life of these products. Periodic inspection and maintenance are essential.

Because RegO products have a long and proven record of quality and service, LP-Gas dealers may forget the hazards that can occur because products are used beyond their safe service life.

The life of a product is determined by the environment in which it "lives." The LP-Gas dealer knows better than anyone what this environment is.

Since 1960, most RegO products are identified with an alphabetical code indicating the month and the year they were manufactured.

Check the product for this code to determine age. If valves or regulators are repainted, take care to keep the date code clear for later identification and inspection.

1960 to 1985 — Two-Letter Date Code

First letter in date code is the month

A — January	G — July
B — February	H — August
C — March	I — September
D — April	J — October
E — May	K — November
F — June	L — December

Relief valves used on ASME tanks carry a numerical code indicating month and year such as 1-75 means January, 1975.

Second letter in date code is the year

R — 1960	A — 1969	J — 1978
S — 1961	B — 1970	K — 1979
T — 1962	C — 1971	L — 1980
U — 1963	D — 1972	M — 1981
V — 1964	E — 1973	N — 1982
W — 1965	F — 1974	O — 1983
X — 1966	G — 1975	P — 1984
Y — 1967	H — 1976	Q — 1985
Z — 1968	I — 1977	

EXAMPLE: DL = April of 1980

From 1985 to 1990 — Digit Date Code

First digit in date code is the month

1 — January	7 — July
2 — February	8 — August
3 — March	9 — September
4 — April	10 — October
5 — May	11 — November
6 — June	12 — December

Second 2 digits in date code are the year

86 — 1986	89 — 1989
87 — 1987	90 — 1990
88 — 1988	

EXAMPLE: 5-87 = May of 1987

After 1990 — Digit-Letter-Digit Date Code

First digit in date code is the month

1 — January	7 — July
2 — February	8 — August
3 — March	9 — September
4 — April	10 — October
5 — May	11 — November
6 — June	12 — December

Letter in date code is the week

A — 1st week
B — 2nd week
C — 3rd week
D — 4th week
E — 5th week

Second 2 digits in date code are the year

91 — 1991	97 — 1997
92 — 1992	98 — 1998
93 — 1993	99 — 1999
94 — 1994	00 — 2000
95 — 1995	01 — 2001
96 — 1996	02 — 2002
03 — 2003	etcetera. . .

EXAMPLE: 6A16 = First week of June, 2016

Regulator Color Coding

RegO Domestic first stage, second stage, single stage, and integral twin stage LP-Gas regulators are easy to identify. In addition to the standard part number marking which indicates the proper application, each regulator is color coded to help minimize misapplication in the field that can lead

to accidents and costly service callbacks. The color coding system is standard on all 404, LV404, 2302, LV2302, 2403, 2503, LV4403, and LV5503 series domestic LP-Gas regulators manufactured after May of 1986.

- Classic Gold** Indicates a single stage regulator that is designed to be used alone in single stage systems.
- Brilliant Red** Denotes a first stage high pressure regulator, normally used in two-stage applications in conjunction with a select brown second stage regulator.
- Select Brown** Signifies second stage low pressure regulators, designed for use in two-stage systems in conjunction with a brilliant red high pressure regulator — also signifies integral twin stage regulators designed to provide benefits of two-stage regulation in one compact unit.
- Select Blue** Indicates a second stage 2 PSIG delivery pressure regulator and a line pressure regulator downstream to reduce 2 PSIG to appliance pressure
- Green** High pressure pounds to pounds anhydrous ammonia regulator.



RegO Innovations - The Tradition Continues

From the company that pioneered propane regulators, you expect nothing less than products that lead the industry. For over 100 years, we have been manufacturing gas regulating equipment to the highest standards of precision and durability—standards that we set.

Our regulators have stood the test of time. The basic design is ingenious. The materials are top quality. The robot-assisted manufacturing is precise. RegO values the relationships we have with our customers, and we stand behind our products.

Our distributors are the best in the industry. Distributors are

indispensable contributors to our success and we treat them as the valuable partners they are. We support our distributors with training, inventory and technical support.

10 Year Warranty on All Products
The RegO 10 Year Warranty is double what most manufacturers offer.

All of our regulators are designed, assembled and tested in North Carolina. Products Made in the USA allow us to maintain our strict quality control standards that are unmatched by any other company. Every single unit is rigorously tested before it goes out the door.

See The Difference

Easy to Service

Seat Discs can be easily accessed by service techs for repair or replacement.

Standard Tools

Bonnet cap requires only hand tightening to ensure a tight seal - no wrench required.

Gas Check Labels

2 Gas Check stickers with product information are included for ease of record keeping.

Double the Warranty

The RegO 10 Year Warranty is double what most manufacturers offer.

Easy to Buy

Supported by the largest network of distributors worldwide.



Easy to Identify

Our bonnet design features patented laser engraved information (part number, date code of manufacture, outlet pressure and serial number) that is easy to see and matches stickers provided for gas check and record keeping.

Easy to Install

Service tech friendly wrench flats for use with an adjustable wrench. Mounting screws included.

Superior Design

Superior vent design has a flathead screwdriver slot for easy removal & minimizes water entering the regulator bonnet.

1

Section 1 **Application Illustrations**

Bulk Transport Truck Illustration

Pressure Relief Valve
A8436G

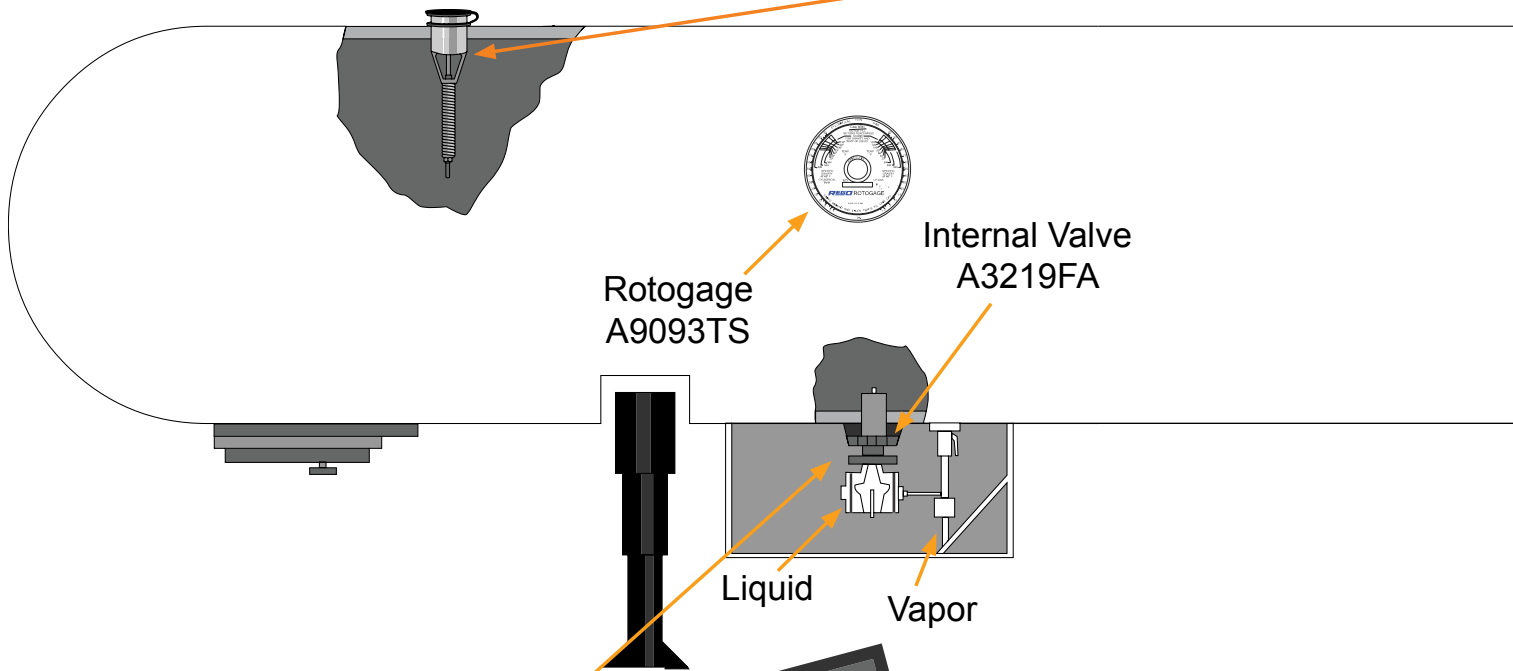

Rotogage
A9093TS

Internal Valve
A3219FA

Liquid
Vapor

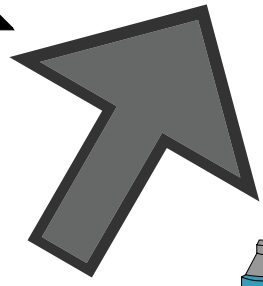

Internal Valve
A3219FA400L
A3219FA600L
with Rotary
Actuator
A3219RA

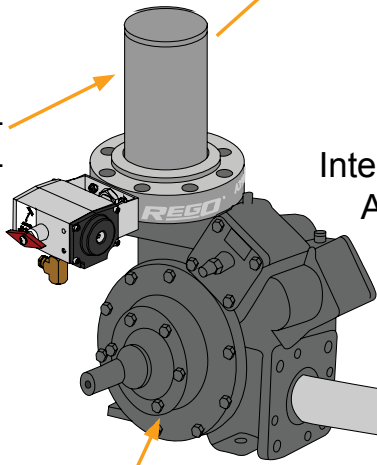

Pump

Internal Valve
A3212R

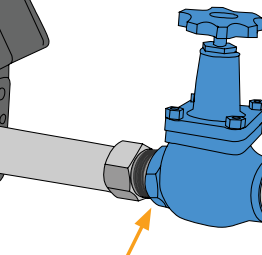

Globe Valve
A7517AP
or A7513AP

Angle Valve
A7704LP

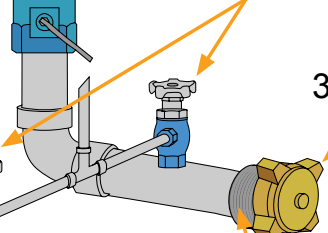

Cap
3184-90

Cap
3194-90

Adapters
5769H
5769K

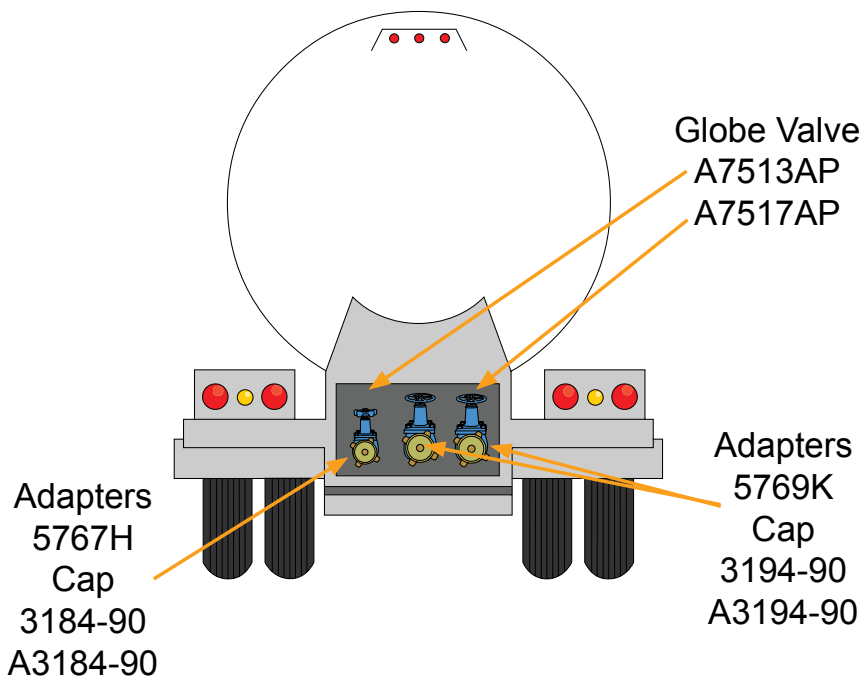
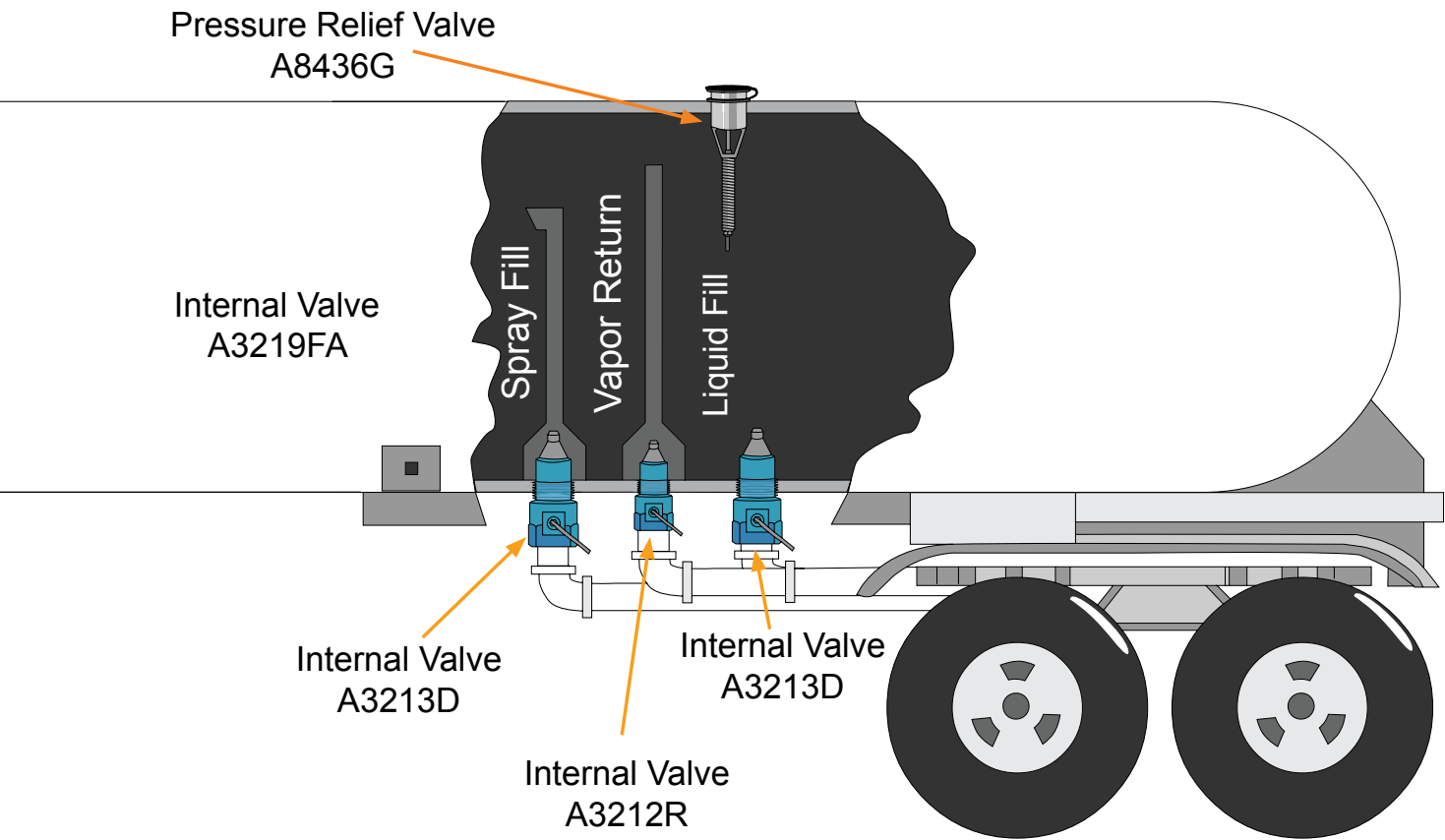

The illustrations in this application guide are intended to inform a professional installer/system designer where our valves are generally installed on certain containers or applications. **These illustrations are not intended for and must not be used for system design.**

© Copyright 2018 Rego®, All Rights Reserved.

Bulk Storage Plant Illustration

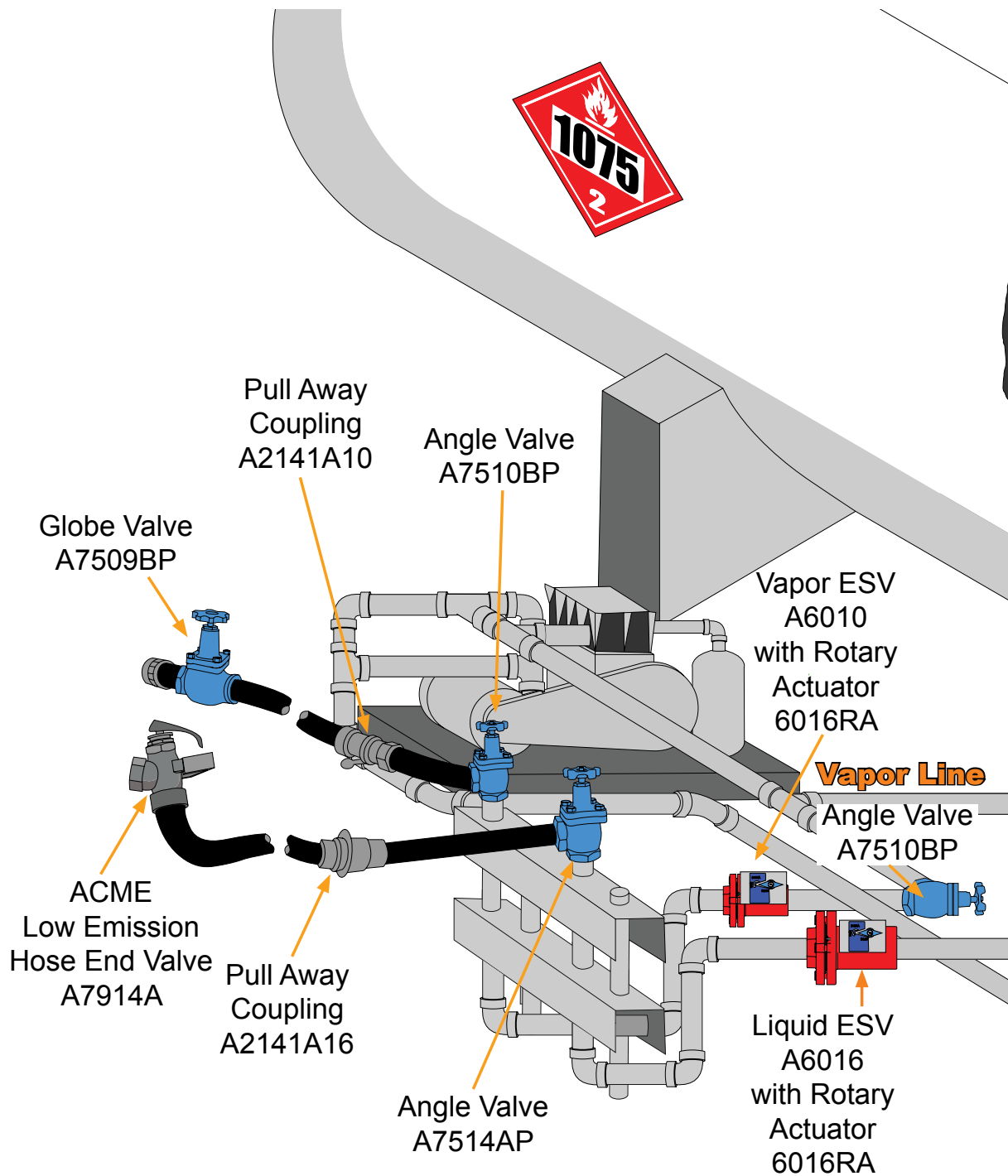

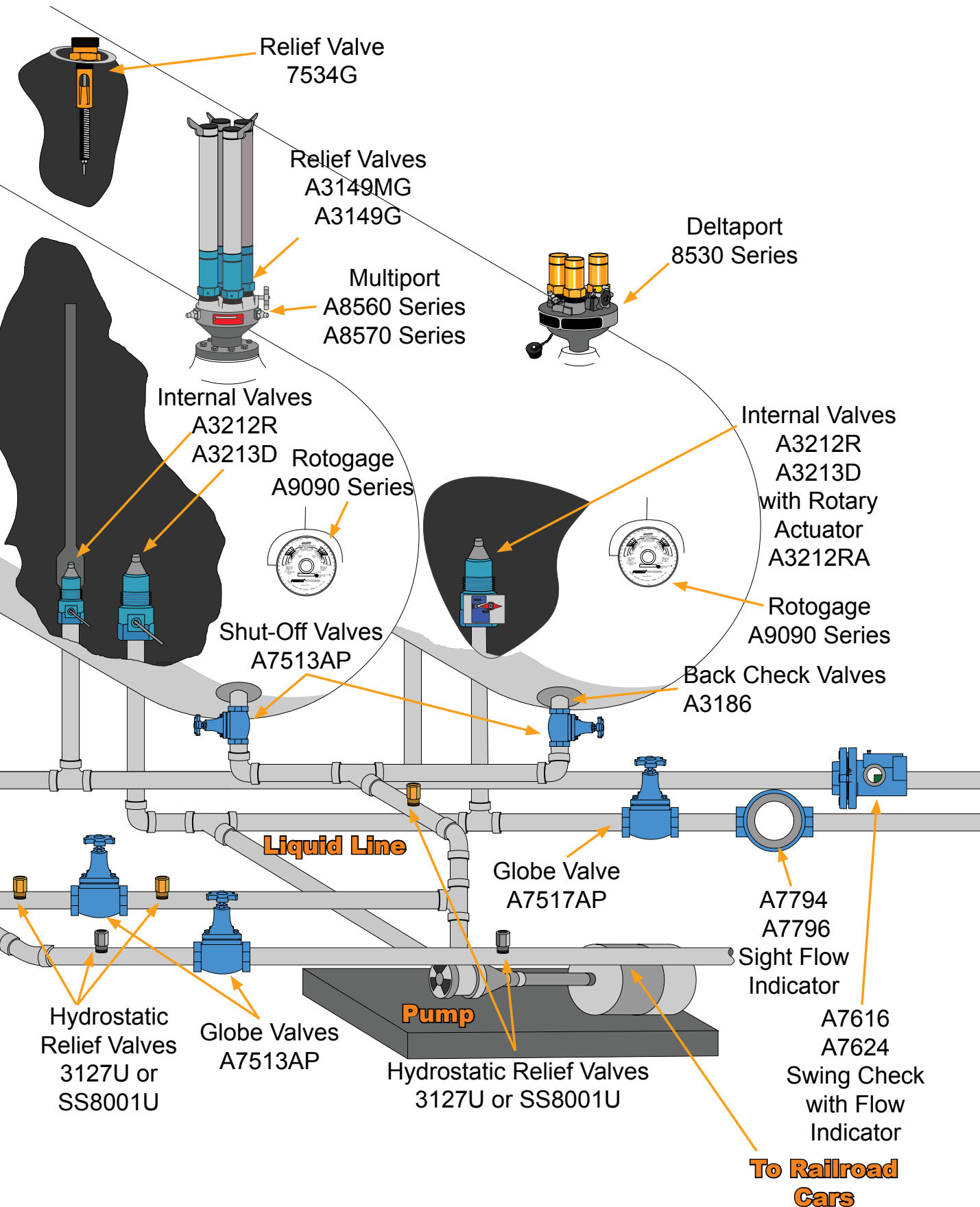

The illustrations in this application guide are intended to inform a professional installer/system designer where our valves are generally installed on certain containers or applications. **These illustrations are not intended for and must not be used for system design.**

© Copyright 2018 Rego®, All Rights Reserved.

Bobtail Delivery Truck Illustrations

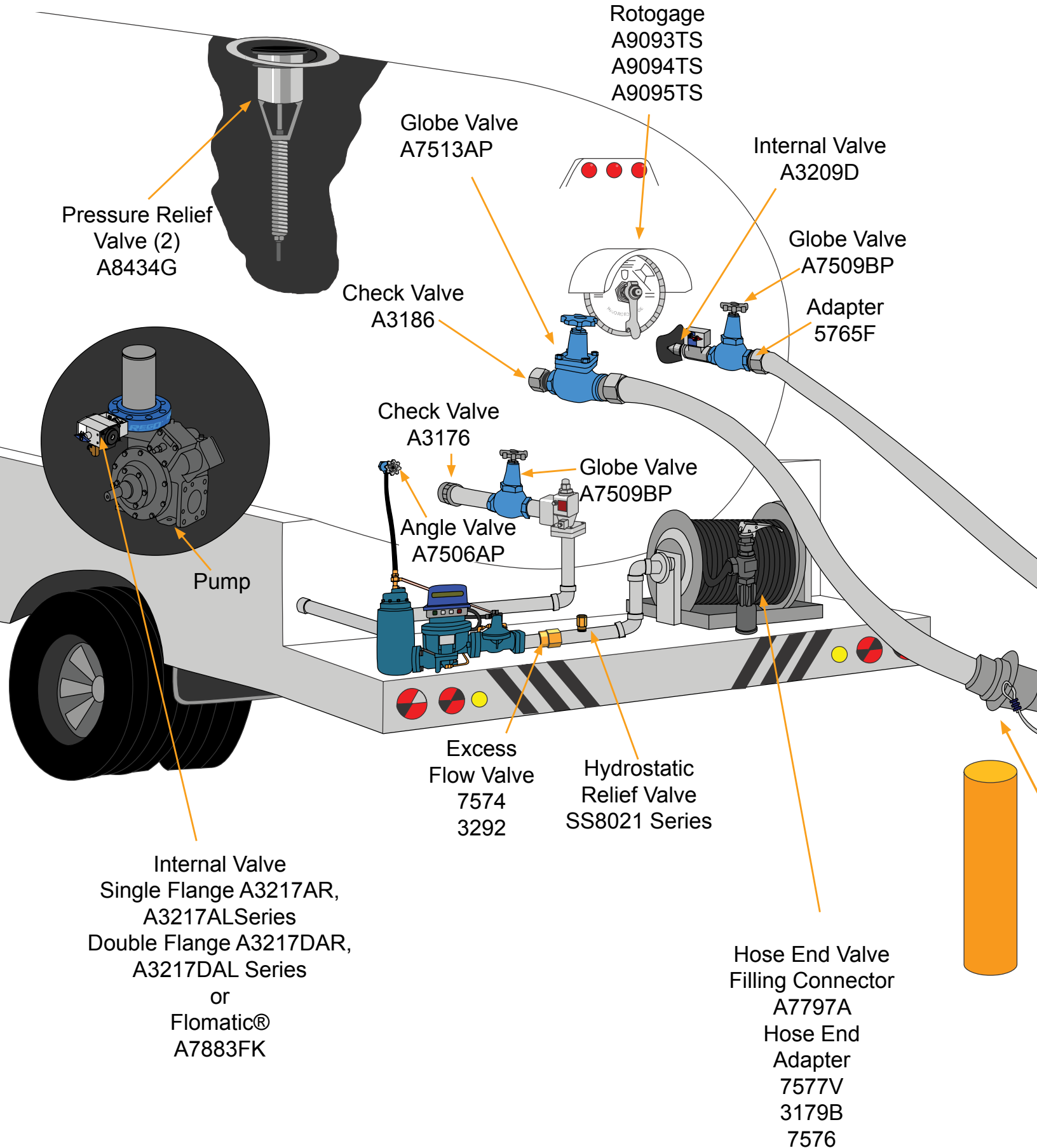

Emergency Shut Off Valves Illustration

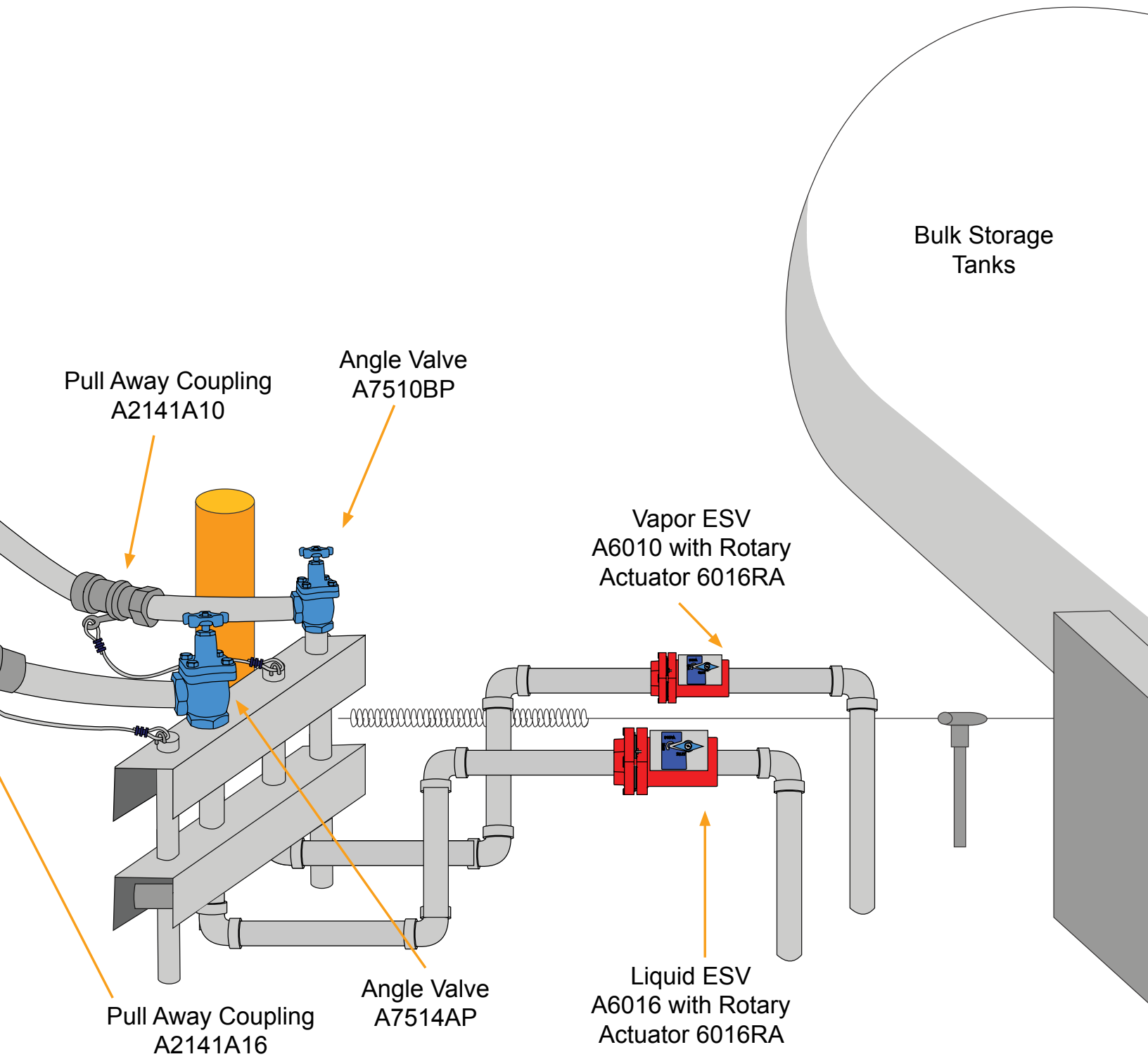

The illustrations in this application guide are intended to inform a professional installer/system designer where our valves are generally installed on certain containers or applications. **These illustrations are not intended for and must not be used for system design.**

© Copyright 2018 Rego®, All Rights Reserved.

Domestic Installations Illustration

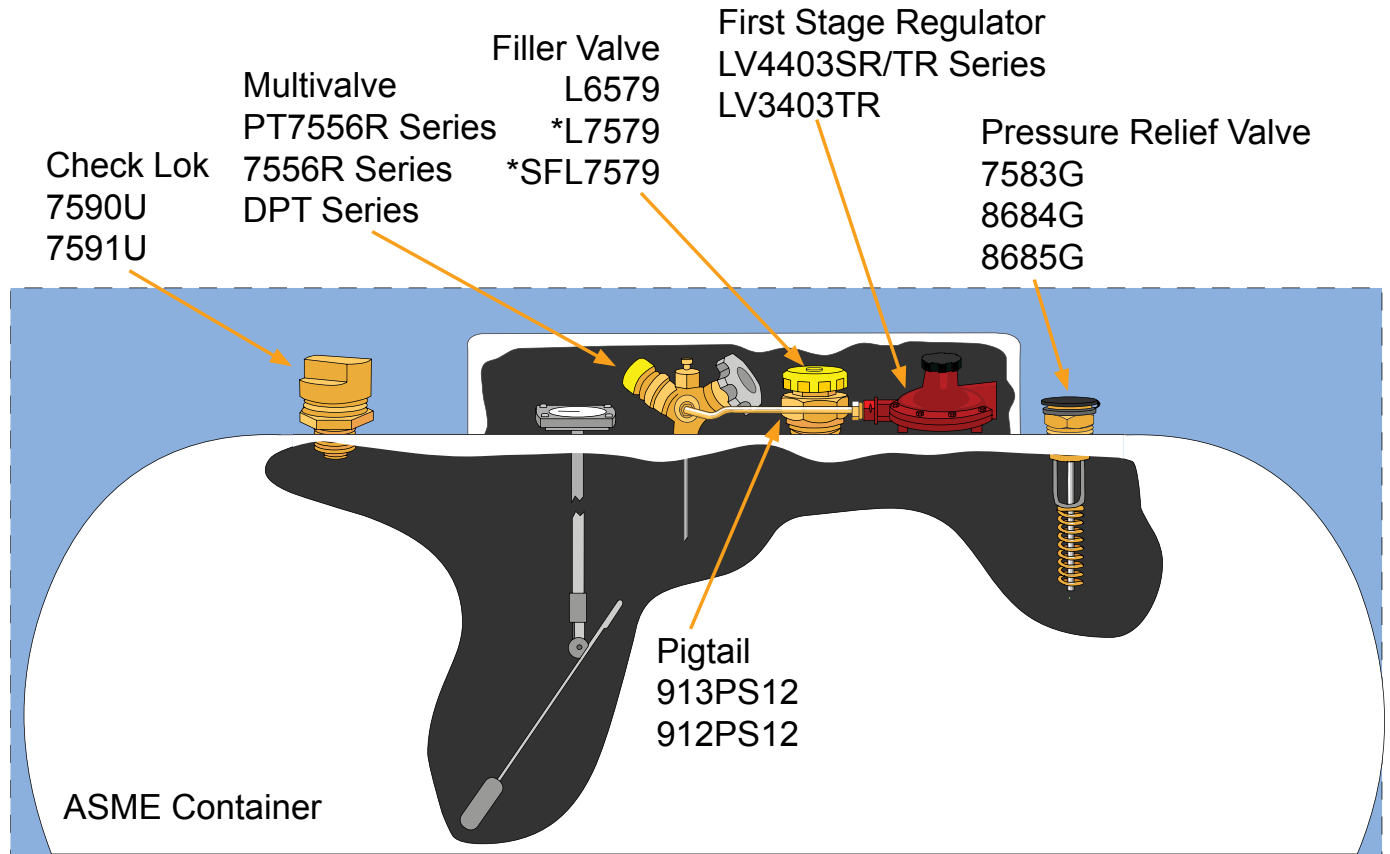

Underground
Multivalve
PG8475RL Series
G8475RL Series

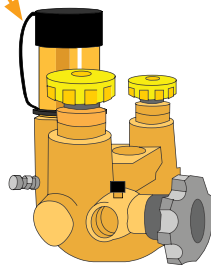

Twin Stage
Regulator
LV404B4 Series
LV404B9 Series
LV404B34 Series
LV404B39 Series
LV404Y Series

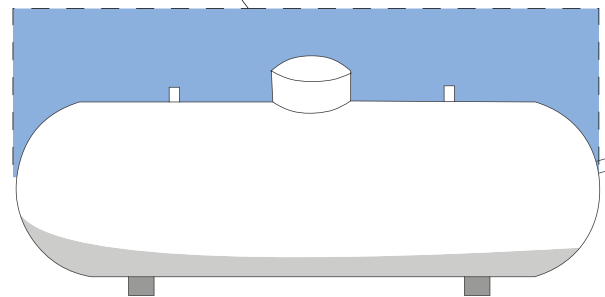
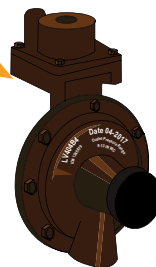

* Low Emissions
** Bleeder

Second Stage Regulator
 LV3403B Series
 LV4403B Series
 LV4403Y Series
 LV5503B Series
 LV3403BR

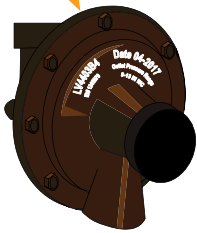

DOT Container

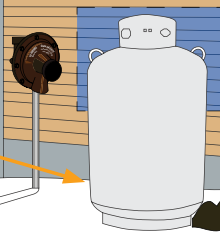

Underground Line

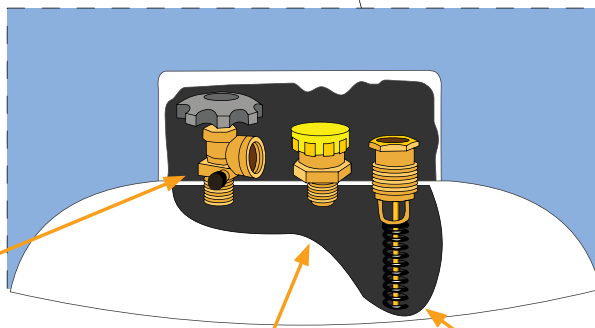

Service Valve
 PT9102R
 PT9102D
 9101R Series
 9101D Series
 9102R Series
 9102D Series

Filler Valve
 *7647SC with cap
 *SFL7647SC
 *L7579

Pressure Relief Valve
 8544 Series

Pigtail
 912J Series
 913J Series
 **D912 Series
 **D913 Series



The illustrations in this application guide are intended to inform a professional installer/system designer where our valves are generally installed on certain containers or applications. **These illustrations are not intended for and must not be used for system design.**

© Copyright 2018 Rego®, All Rights Reserved.

Motor Fuel Illustrations

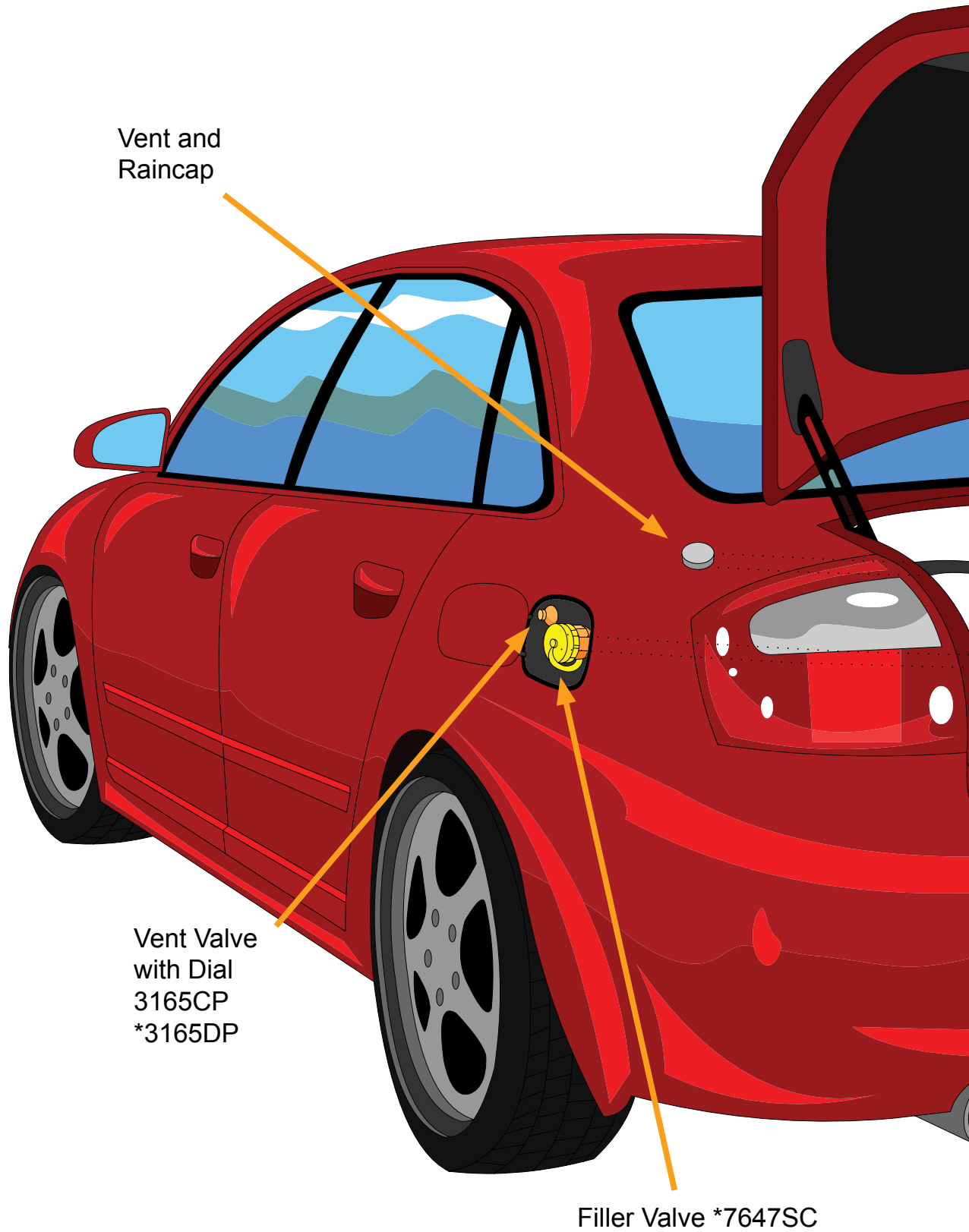

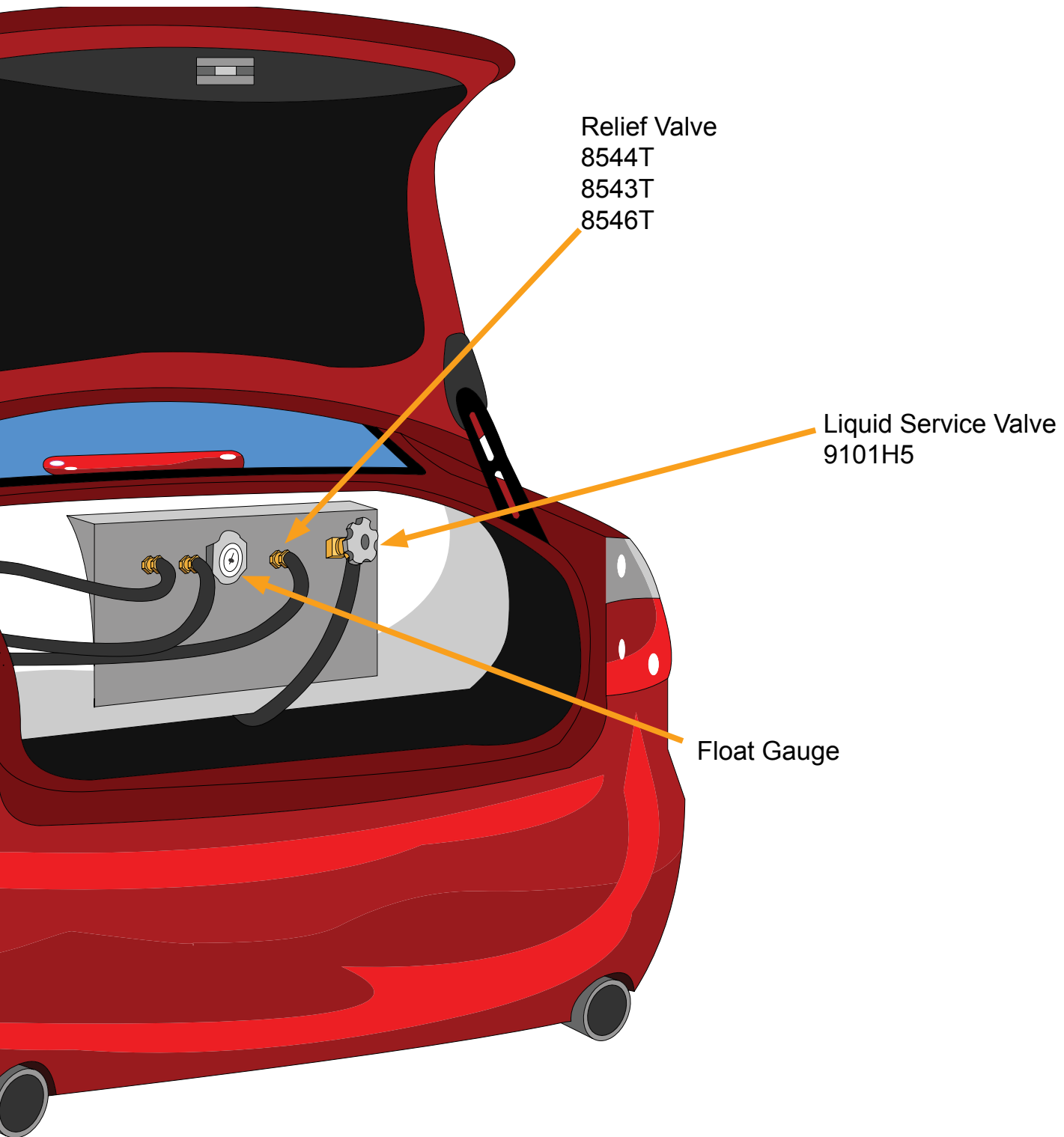

* Low Emission

The illustrations in this application guide are intended to inform a professional installer/system designer where our valves are generally installed on certain containers or applications. **These illustrations are not intended for and must not be used for system design.**

© Copyright 2018 Rego®, All Rights Reserved.

Cylinder Valve Illustrations

Service Valve
 *9101R Series
 *9101D
 *9102R
 *9102D
 *PT9102R
 *PT9102D

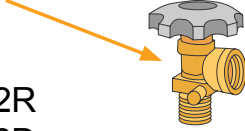

Double Check Fill Valve
 **7647SC with cap
 **L7579



DOT Vapor Multivalve
 6533R/6543R
 PT6542 Series
 PT6543 Series

DOT Pressure Relief Valve
 8544K Series

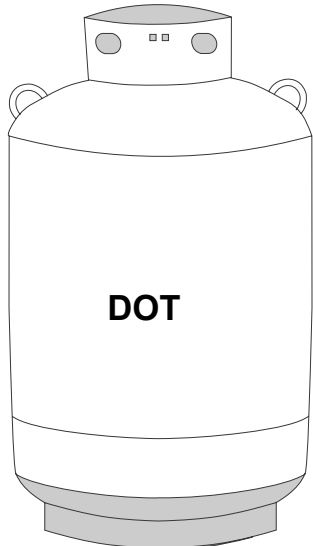
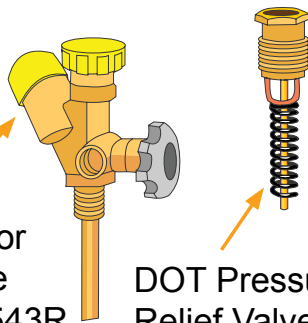

420 lbs.

* Low Emission Version Available
 ** Standard Low Emission Products

Service Valve
 *9101R Series
 *9101D
 *9102R
 *9102D
 *PT9102R
 *PT9102D

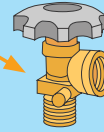

Double Check Fill Valve
 **7647SC with cap
 **L7579



ASME Vapor Multivalve
 6532R/6542R

ASME Pressure Relief Valve
 8544G Series

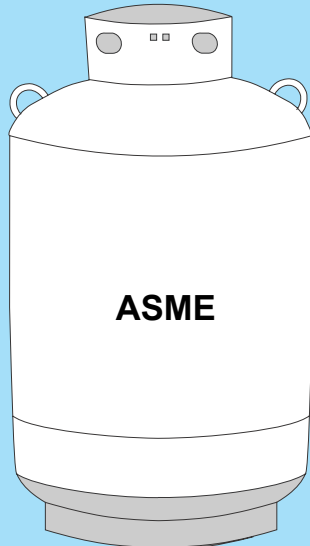
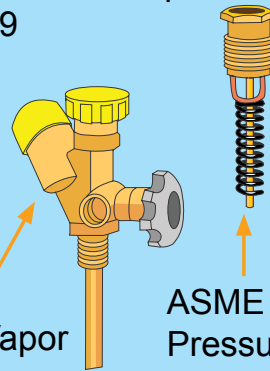

120 Gallons w.c.

Vapor Multivalve
 *6555R Series
 *6555D
 (Up to 60 gallon w.c.
 ASME Containers)

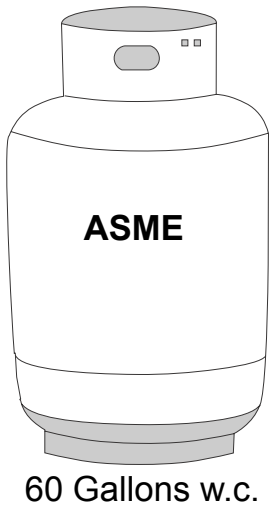
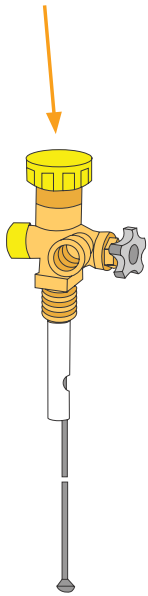

Liquid
 9107K8A
 *D9107K8A

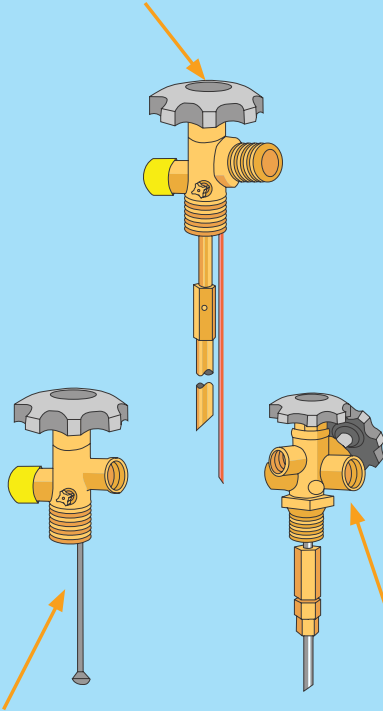

Vapor
 9103D
 *D9103



Dual Purpose
 8556

Liquid Multivalve
 855DL
 *D8555DL

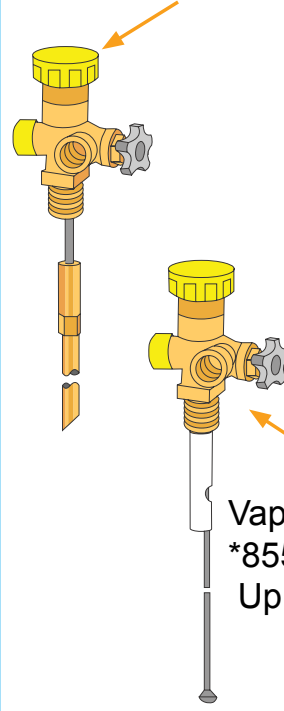

Vapor Multivalve
 *8555D or R Series
 Up to 200 lb. DOT

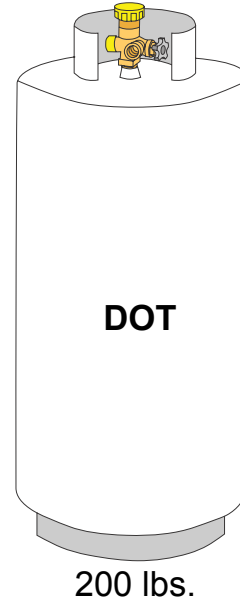

The illustrations in this application guide are intended to inform a professional installer/system designer where our valves are generally installed on certain containers or applications. **These illustrations are not intended for and must not be used for system design.**

© Copyright 2018 Rego®, All Rights Reserved.

Motor Fuel Illustrations

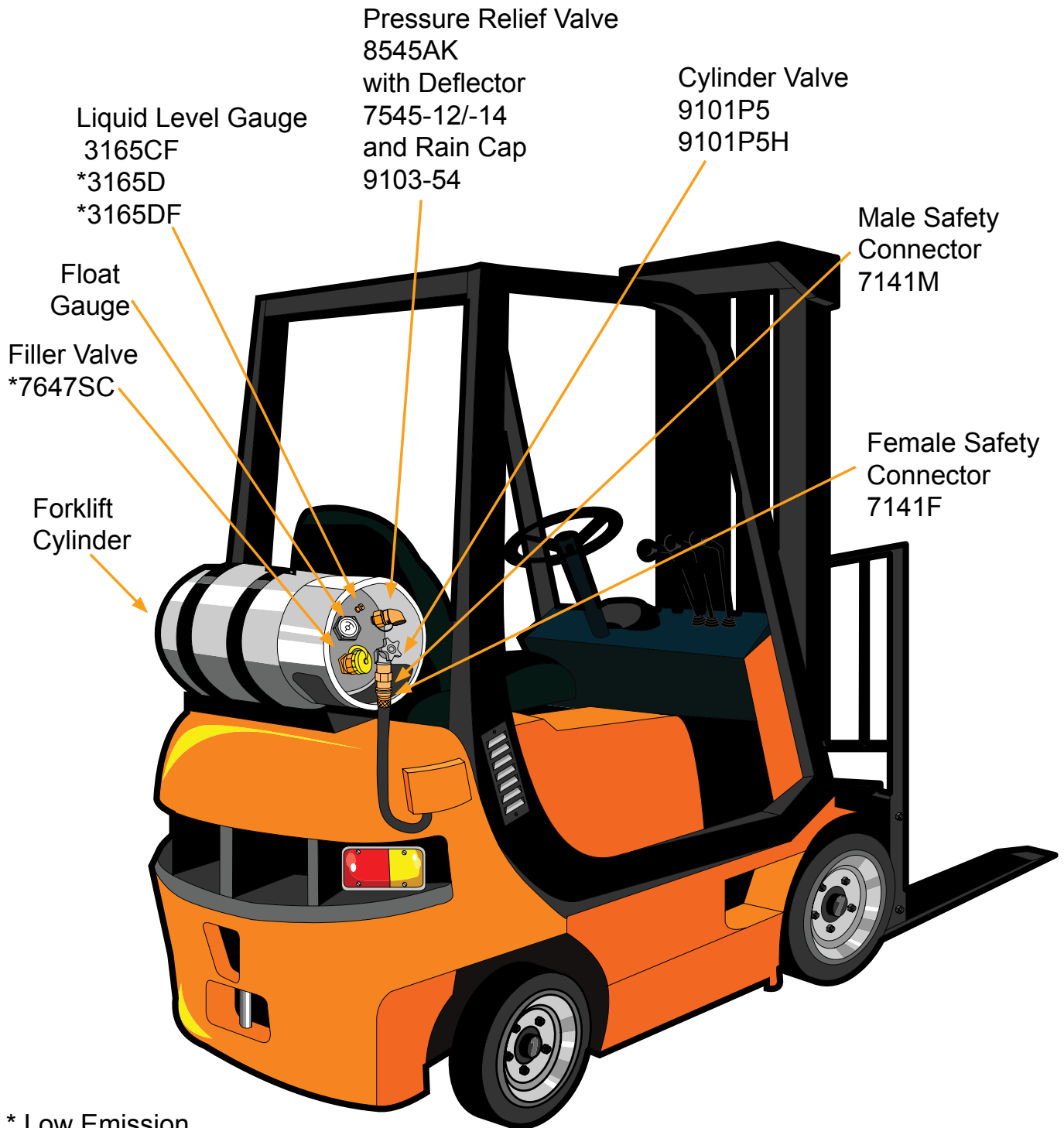

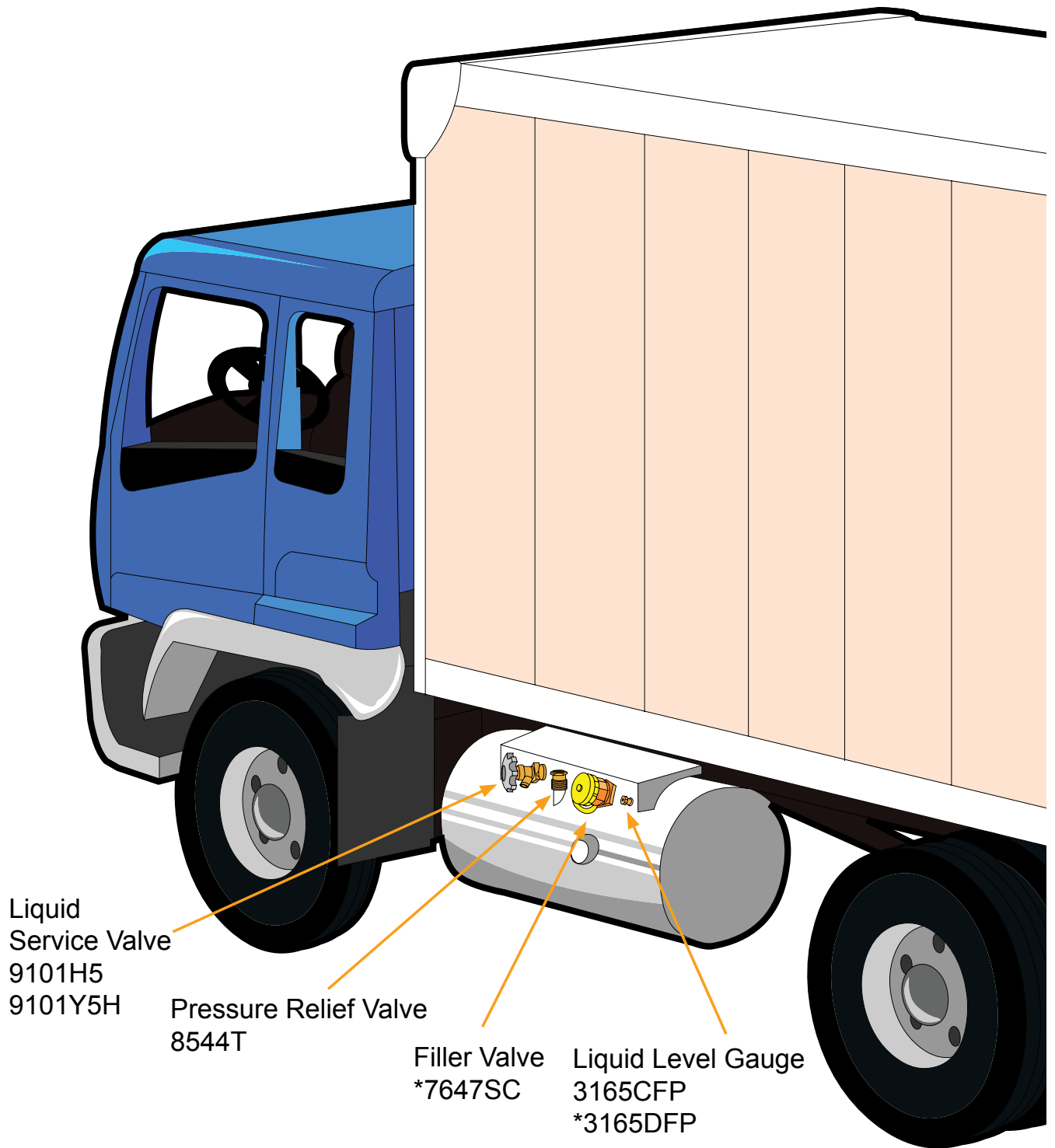

The illustrations in this application guide are intended to inform a professional installer/system designer where our valves are generally installed on certain containers or applications. **These illustrations are not intended for and must not be used for system design.**

© Copyright 2018 Rego®, All Rights Reserved.

Recreational Illustrations

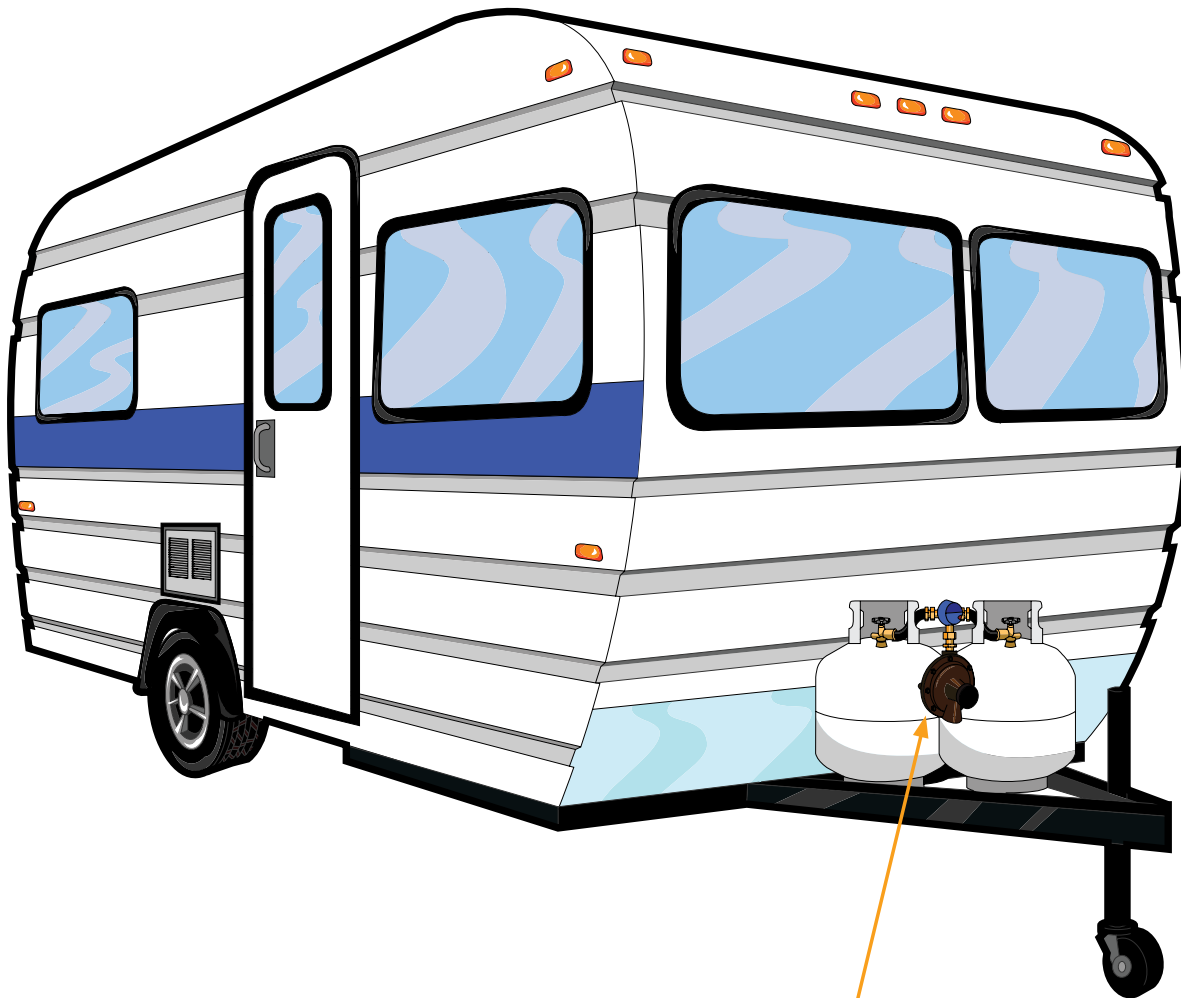

Automatic Changeover
7525B34 Series
7525B4 Series

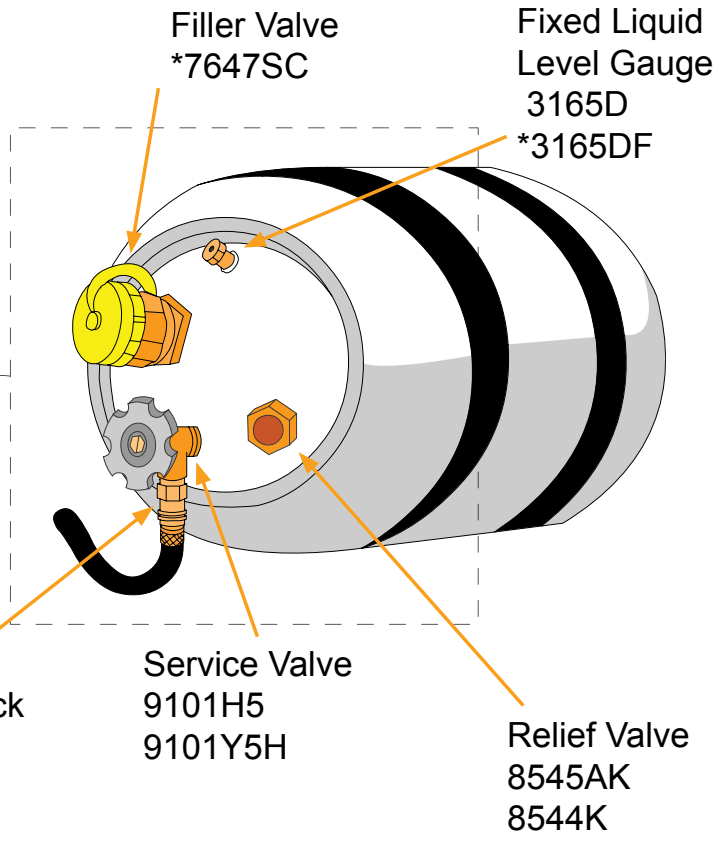

ACME Check
Connectors
7142LM
7142LF

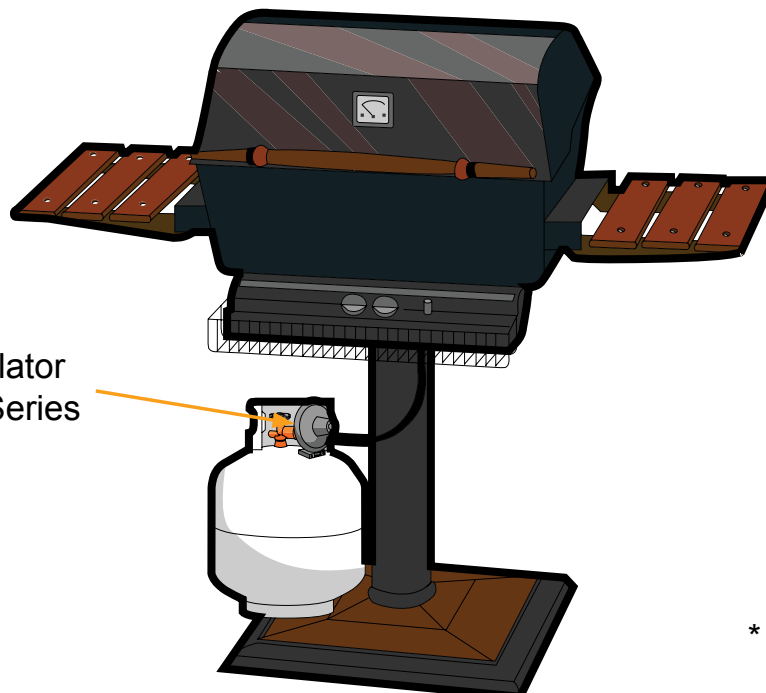

Regulator
302 Series

* Low Emission

The illustrations in this application guide are intended to inform a professional installer/system designer where our valves are generally installed on certain containers or applications. **These illustrations are not intended for and must not be used for system design.**

© Copyright 2018 RegO®, All Rights Reserved.

Anhydrous Ammonia

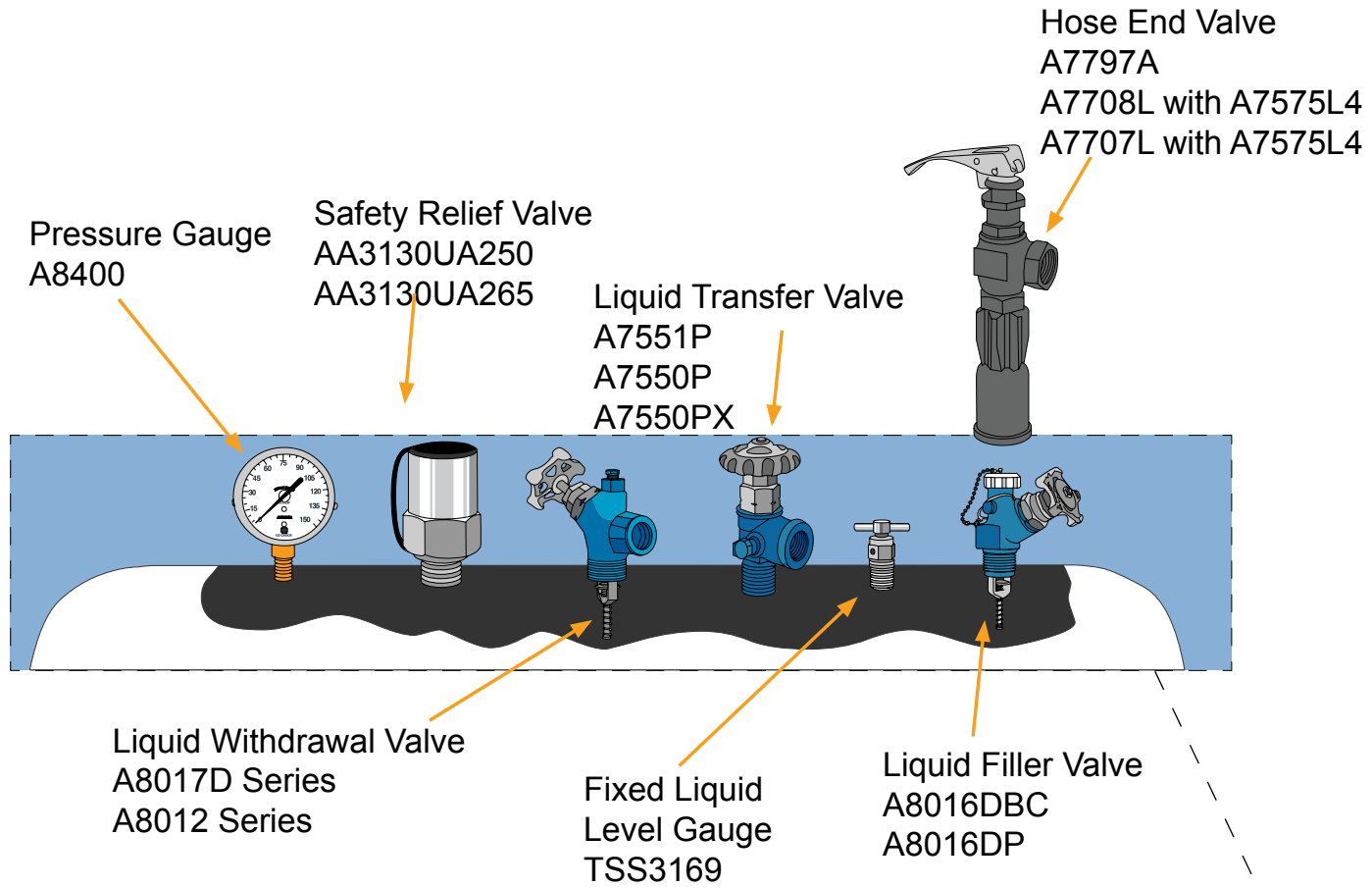

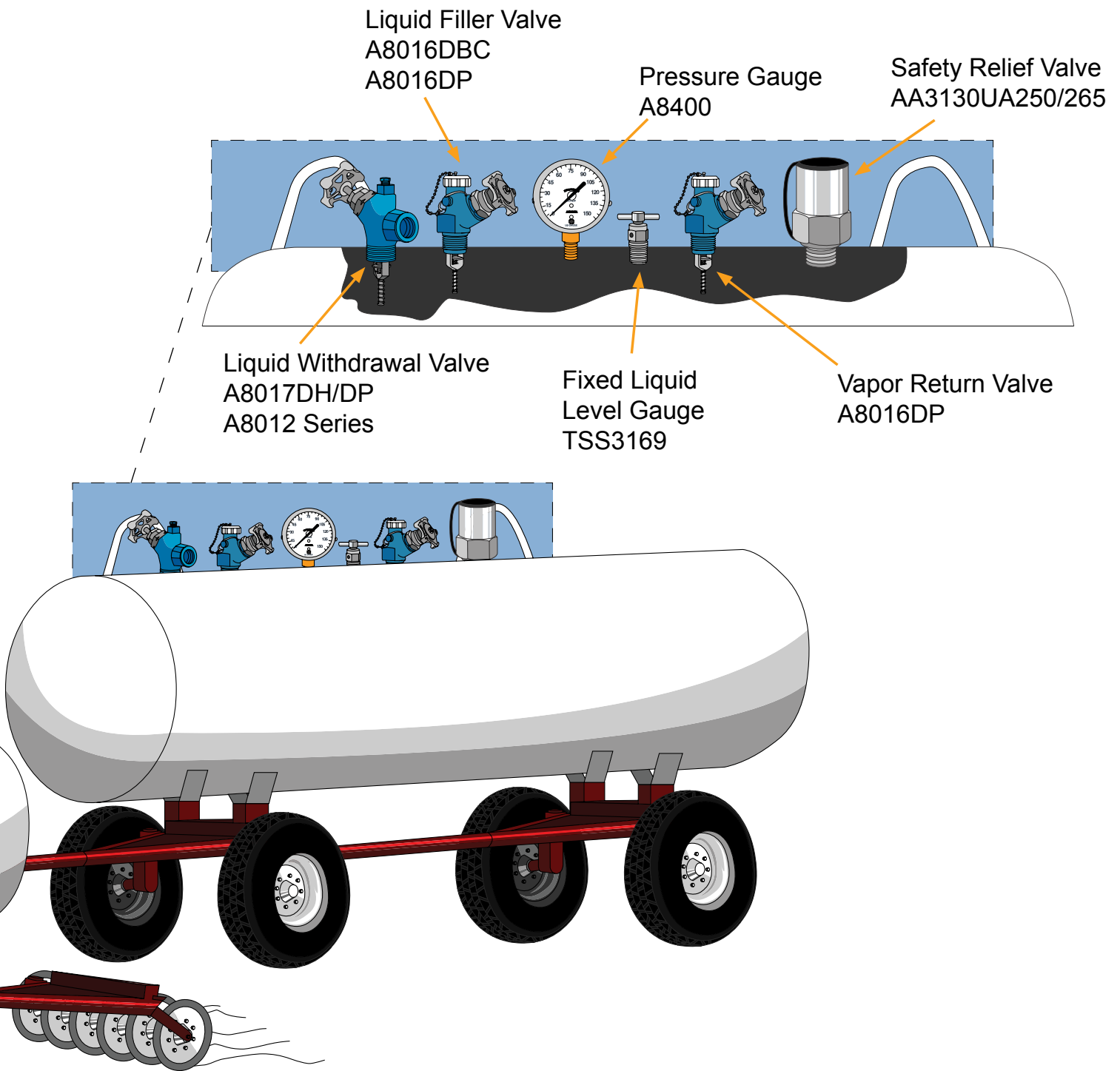

The illustrations in this application guide are intended to inform a professional installer/system designer where our valves are generally installed on certain containers or applications. **These illustrations are not intended for and must not be used for system design.**

© Copyright 2018 Rego®, All Rights Reserved.

Section A
Regulators and Accessories



Limited 10 Year Warranty and Limitation Of Liability

LIMITED 10 YEAR WARRANTY

RegO warrants to the original purchasers the products and repair kits manufactured by it to be free from defects in materials and workmanship under normal use and service for a period of 10 years from the date of manufacture. If within thirty days after buyer's discovery of what buyer believes is a defect, buyer notifies in writing and ships the product to RegO at 100 RegO Drive, Elon, NC 27244, RegO, at its option, and within forty-five days of receipt, will repair, replace F.O.B. point of manufacture, or refund the purchase price of that part or product found by RegO to be defective. Failure of buyer to give such written notice and ship the product within thirty days shall be deemed an absolute and unconditional waiver of any and all claims of buyer arising out of such defect.

This warranty does not extend to any product or part that is not installed and used after installation in accordance with RegO's printed instructions, all applicable state and local regulations, and all applicable national standards, such as those promulgated by NFPA, DOT and ANSI. This warranty does not extend to any product or part that has been damaged by accident, misuse, abuse, failure to maintain, or neglect, nor does it extend to any product or part which has been modified, altered, disassembled, or repaired in the field. This warranty does not cover any cosmetic issues, such as scratches, dents, marring, fading of colors or discoloration.

Except as expressly set forth above, and subject to the limitation of liability below, RegO MAKES NO OTHER WARRANTY, EXPRESS OR IMPLIED, INCLUDING, BUT NOT LIMITED TO, THE IMPLIED WARRANTIES OF MERCHANTABILITY AND FITNESS FOR A PARTICULAR PURPOSE, with respect to its products and parts, whether used alone or in combination with others. RegO disclaims all warranties not stated herein.

LIMITATION OF LIABILITY

RegO's total liability for any and all losses and damages arising out of any cause whatsoever shall in no event exceed the purchase price of the products or parts in respect of which such cause arises, whether such cause be based on theories of contract, negligence, strict liability, tort or otherwise.

RegO shall not be liable for incidental, consequential or punitive damages or other losses. RegO shall not be liable for, and buyer assumes any liability for, all personal injury and property damage connected with the handling, transportation, possession, further manufacture, other use or resale of products, whether used alone or in combination with any other products or materials.

From time to time buyers might call to ask RegO for technical advice based upon limited facts disclosed to RegO. If RegO furnishes technical advice to buyer, whether or not at buyer's request, with respect to application, further manufacture or other use of the products and parts, RegO shall not be liable for such technical advice or any such advice provided to buyer by any third party and buyer assumes all risks of such advice and the results thereof.

NOTE: Some states do not allow the exclusion or limitation of incidental, consequential or punitive damages, so the above limitation or exclusion may not apply to you. The warranty gives you specific legal rights, and you may have other rights that vary from State to State. The portions of this limited warranty and limitation of liability shall be considered severable and all portions which are not disallowed by applicable law shall remain in full force and effect.

WARNING

All RegO products are mechanical devices that will eventually become inoperative due to wear, corrosion and aging of components made of material such as rubber, etc. The environment and conditions of use will determine the safe service life of these products. Periodic inspection and maintenance are essential to avoid serious injury and property damage.

Many RegO products are manufactured components which are incorporated by others on or in other products or systems used for storage, transport, transfer and otherwise for use of toxic, flammable and dangerous liquids and gases. Such substances must be handled by experienced and trained personnel only, using accepted governmental and industrial safety procedures.

NOTICE TO USERS OF PRODUCTS

The Limited Warranty stated above is a factory warranty to the first purchasers of RegO products. Since most users have purchased these products from RegO distributors, the user must within thirty (30) days after the user's discovery of what user believes is a defect, notify in writing and return the product to the distributor from whom he purchased the product/part. The distributor may or may not at the distributor's option choose to submit the product/parts to RegO, pursuant to this Limited Warranty. Failure by buyer to give such written notice within thirty (30) days shall be deemed an absolute and unconditional waiver of buyer's claim for such defects. Acceptance of any alleged defective product/parts by RegO's distributor for replacement or repairs under the terms of RegO's Limited Warranty in no way determines RegO's obligations under this Limited Warranty.

Because of a policy of continuous product improvement, RegO reserves the right to change designs, materials or specifications without notice.

Foreword

This catalog describes a complete line of equipment available from RegO® for use with Liquid Propane (LP)-Gas and anhydrous ammonia (NH₃). The following points are important to know for proper use of the catalog:

1. Illustrations and drawings of individual products are representative of “product groups” and all products within a product group are similar in construction.
2. Materials used for construction of products in this catalog are suitable for rated service pressure at temperatures of -40°F to +165°F, unless otherwise specified.
3. Products in this catalog are only intended for use in LP-Gas and/or anhydrous ammonia service as follows.
 - a. “A” or “AA” prefix — Products with this prefix are suitable for NH₃ service (i.e., contain no brass parts).
 - b. “AA” prefix on relief valves — These valves are NOT suitable for use with LP-Gas service. These are of partial aluminum materials and are listed by Underwriters Laboratories (UL) for NH₃ service only.
 - c. All other products including “A” prefix are suitable for use with LP-Gas & NH₃ service.
 - d. “SS” prefix—Hydrostatic relief valve with this prefix are suitable for NH₃ and LP-Gas service (i.e., they have stainless steel materials).
4. We manufacture valves and adapters designed to be used on LP-Gas and Anhydrous Ammonia systems, we do not design systems or consult in system design. For this type of information consult a professional Engineer.

Caution

Do not use any product contained in this catalog with any service commodity other than LP-Gas or NH₃. If you have a need for use of another application, contact RegO, 100 RegO Drive, Elon, NC 27244, (336) 449-7707 ecii@regoproducts.com before proceeding.

Proper application, installation and maintenance of products in this catalog are essential. Users of these products should obtain further information if there are any doubts or questions.

Warning

All RegO products are mechanical devices that will eventually become inoperative due to wear, corrosion and aging of components made of materials such as rubber. The environment and conditions of use will determine the safe service life of these products. Periodic inspection and maintenance are essential to avoid serious injury and property damage.

Many RegO products are manufactured for storage, transport, transfer and use of toxic flammable and dangerous liquids and gases. Such substances should be handled by experienced and trained personnel only, using accepted governmental and industrial safety procedures. Never vent LP-Gas near any possible source of ignition.

Notice

Installation, usage, and maintenance of all RegO products must be in compliance with all RegO instructions as well as requirements and provisions of NFPA #54, NFPA#58, DOT, ANSI, and all applicable federal, state, provincial and local standards, codes, regulations, and laws.

Inspection and maintenance on a periodic basis is essential. Installation and maintenance should be performed only by qualified personnel.

Be sure all instructions are read and understood before installation, operation and service.

Filters

RegO LP-Gas equipment is designed to operate in a system free from contamination. A variety of in-line filters are commercially available to the LP-Gas industry for installation in domestic systems.

The use of an in-line filter should be considered when other system components may be unclean and the system contaminated by rust, scale, dirt, debris or other foreign material.

RegO Regulator Dependability

When RegO LP-Gas Regulators are properly installed, safe, precise, trouble-free service is the result.

Dependability is built into every regulator ... the result of rigid standards of quality control and close tolerance machining. And this has been true for more than 90 years.

RegO Products are manufactured from the finest materials, and assembled and tested using procedures second to none.

RegO Regulator Selection

In order to properly size the RegO Regulator, find the total load of the installation. The total load is calculated by adding up the input ratings (BTU or CFH) of all appliances in the installation. Input ratings may be obtained from the nameplates on the appliances or from the manufacturers' literature.

Determine the type of regulation needed referring to the chart below.

Type of System	Maximum Load	Suggested Regulator
First Stage in a Two Stage System	1,500,000	LV3403TR
	2,500,000	LV4403SR Series LV4403TR Series
Second Stage in a Two Stage System	450,000	LV3403B Series LV3403BR Series
	935,000	LV4403B Series LV4403BD Series
	1,600,000	LV5503B4/B6
	2,300,000	LV5503B8
	2,200,000	LV5503Y6/Y8
Second Stage in a 2 PSIG System	1,000,000	LV4403Y4/Y46R
	2,200,000	LV5503Y6/Y8
Integral Twin Stage	450,000	LV404B34/39 Series
	525,000	LV404B4/B9 Series
Integral Twin Stage 2 PSIG Delivery	800,000	LV404Y9
	650,000	LV404Y39
Automatic Changeover	400,000	7525B34 Series
	450,000	7525B4 Series

* See catalog page for inlet and delivery specifications.

Now determine which regulator in the Series would be most suitable. Turn to the individual product pages and refer to the Performance Curves. Check the performance of the regulator with your actual load conditions at the minimum LP-Gas inlet pressure for the regulator. Use the pressure corresponding to your lowest winter temperatures shown in the chart below or refer to the delivery pressure of your first stage regulator.

Temperature		Approx. Pressure (PSIG)		Temperature		Approx. Pressure (PSIG)	
°F	°C	Propane	Butane	°F	°C	Propane	Butane
-40	-40	3.6		40	4	72	3.0
-30	-34	8		50	10	86	6.9
-20	-29	13.5		60	16	102	12
-10	-23	23.3		70	21	127	17
0	-18	28		80	27	140	23
10	-12	37		90	32	165	29
20	-7	47		100	38	196	36
30	-1	58		110	43	220	45

Example for a First Stage Regulator

1. Assume a load of 500,000 BTU's per hour.
2. Assume a minimum delivery pressure of 9.5 PSIG.
3. Assume a minimum tank pressure of 15 PSIG.
4. For these conditions, refer to chart for the LV4403TR Series, First Stage Regulator, shown below.

All give you a product that provides accurate gas delivery under varying pressure ranges and load conditions.

RegO LP-Gas Regulators are UL listed and comply with applicable code requirements.

RegO Products offer a complete line of LP-Gas Regulators with capacities for almost every application.

5. Find the line on the chart corresponding to the lowest anticipated winter tank pressure (note that each performance line corresponds to and is marked with a different inlet pressure in PSIG).
6. Draw a vertical line upward from the point of assumed load (500,000 BTU's per hour) to intersect with the line corresponding to the lowest tank pressure.
7. Read horizontally from the intersection of these lines to the delivery pressure at the left side of the chart. In this example the delivery pressure will be 9.7 PSIG. Since the delivery pressure will be 9.7 PSIG at the maximum load conditions and lowest anticipated tank pressure, the regulator will be sized properly for the demand.

Example for a Second Stage Regulator

LV4403TR Series First Stage Regulator

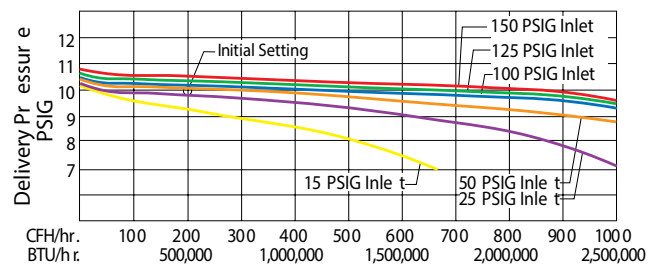

1. Assume load of 250,000 BTU's per hour.
2. Assume a minimum delivery pressure of 10" w.c.
3. Assume a minimum inlet pressure of 10 PSIG.
4. For these conditions, refer to chart for the LV4403B Series, Second Stage Regulator, shown below.
5. Find the line on the chart corresponding to the anticipated inlet pressure.
6. Draw a vertical line upward from the point of assumed load (250,000 BTU's per hour) to intersect with the line corresponding to the lowest inlet pressure.
7. Read horizontally from the intersection of these lines to the delivery pressure at the left side of the chart. In this example the delivery pressure will read 10.6" w.c. Since the delivery pressure will be 10.6" w.c. at the maximum load condition and lowest anticipated inlet pressure, the regulator is sized properly for the demand.

LV4403B Series Second Stage Regulator

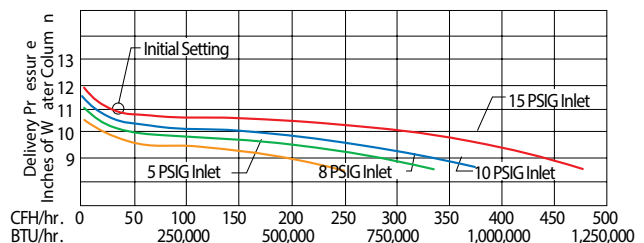

Safety Warnings



Purpose

In its continuing quest for safety, RegO publishes a series of bulletins explaining the hazards associated with the use, misuse, and aging of LP-Gas valves and regulators. It is hoped that these factual bulletins will make clear to LP-Gas dealer managers and service personnel, that the utmost care and attention must be used in the installation, inspection, and maintenance of these products, or problems could occur which would result in injuries and property damage.

The National Fire Protection Association NFPA 58 Liquefied Petroleum Gas Code - 2017 Edition states in Section 4.4 Qualification of Personnel; "Persons whose duties fall within the scope of this code shall be provided with training that is consistent with the scope of their job activities and that includes proper handling and emergency response procedures... Refresher training shall be provided at least every 3 years, initial and subsequent training shall be documented". These "RegO Safety Warnings" may be useful in training new employees and reminding older employees of hazards that can occur. It is recommended that all employees complete the Propane Education Research Council's Certified Employee Training Program.

Nature of Warnings

It is recognized that warnings should be as brief as possible, but the factors involved in regulator failures are not simple. They need to be fully understood so that proper maintenance programs can be established. If there is a simple warning, it would be:

Inspect regulators regularly as outlined in this safety warning and replace as required per these recommendations. When all of these recommendations are followed, the recommended service life of an RegO regulator (except single stage) manufactured after 1995 is 25 years. The recommended service life of all other RegO regulators is 15 years.

LP-Gas Regulators

This bulletin applies most particularly to permanent LP-Gas installations of cylinders and tanks. The warnings also apply in most cases to portable installations of recreational vehicles, barbecue grills, etc. This bulletin is not intended to be an exhaustive treatment of the subject of regulators and certainly does not cover all safety practices that should be followed in the installation and maintenance of LP-Gas systems.

It should not be necessary to remind readers of this bulletin that regulators must be installed in strict conformance with NFPA Pamphlets 54 and 58, and all other applicable codes and regulations. Codes, regulations and manufacturer's recommendations have been developed by experts with many years of experience in the LP-Gas industry.

Failure to fully follow these codes, regulations and recommendations could result in hazardous installations.

Pamphlet 58 states "All regulators for outdoor installations, except regulators used for portable industrial applications, shall be designed, installed or protected so their operation will not be affected by the elements (freezing rain, sleet, snow, ice, mud or debris). This protection may be integral with the regulator."

Failed and/or Inoperative Regulators

Failed regulators can cause three kinds of hazards:

- High pressure LP-Gas in a system downstream of the regulator; and
- Leaks of LP-Gas to atmosphere from the regulator itself.
- Loss of pressure due to a "freeze-up" in the orifice.

High Pressure LP-Gas in a System

Anything that prevents a regulator from regulating properly could result in high pressure gas at the regulator outlet and thus in a system.

High pressure gas into piping and appliances could cause piping leaks and damage to appliance burner controls with the potential for fires and explosions.

The Causes of High Pressure Gas in a System are:

1. Regulator vents that are clogged or obstructed.

Vents must be clear and fully open at all times.

Many regulators are equipped with a pressure relief valve which discharges to atmosphere through the vent. Ice, snow drifts, dirt, bugs, paint, or other foreign material can clog the vents.

An obstructed vent may prevent the pressure relief valve from operating properly.

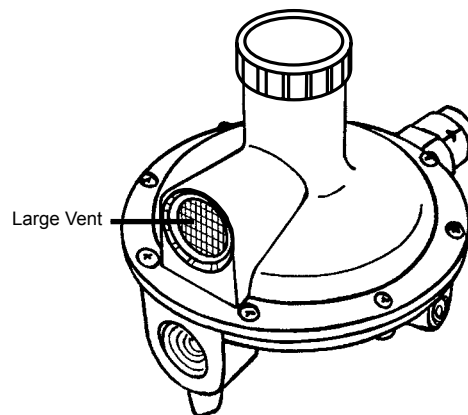

Regulators should be installed with the vent facing down or protected so their operation will not be affected by the elements. In cases where the regulator vent is equipped with a discharge tube, the outlet of this tube must be facing down. The vents and/or discharge tubes must be protected from the elements and must be equipped with a screen to prevent bugs from obstructing the opening.

Action Required: Regulators should be properly installed and regularly inspected when tanks or cylinders are filled. If vents are clogged or the screen is missing, they must be cleaned or replaced. If the vent screen is missing and there is evidence of foreign material around the vent, the regulator should be replaced.

2. Foreign material lodging between the regulator nozzle and seat disc:

When this occurs, the regulator can remain open, allowing high pressure gas into the system.

Safety Warnings

This material can come from system piping between the container shut-off valve and the regulator. Chips created during piping installation or dirty piping can create this hazard. Corrosion inside of copper pigtailed and piping can cause problems. This can occur particularly when LP-Gas contains high sulphur or excessive moisture.

Action Required: Make sure regulator inlet piping is clean at the time of installation. Periodic checks should be made to ensure piping remains clean without corrosion. Never use old pigtailed on new LP-Gas installations. Old pigtailed can also work harden and crack if they have been bent and twisted several times.

3. Wrong regulator installed for the application:

The proper regulator must be used for each system.

For example, installation of high pressure regulators not designed to reduce gas pressure to an appliance requirement of 11" w.c. will cause a hazard. Installing a regulator undersized for the load can cause improper combustion at the appliance burner with a potential for carbon monoxide poisoning.

Action Required: Make sure the regulator is correct for each application and test the system with a pressure gauge or a manometer.

4. Failure to external mechanical parts due to corrosion:

Adjusting springs and relief valve springs can rapidly corrode if exposed to salt air or industrial pollution. Even moisture condensation on these springs can cause them to rust and fail.

Failure of these springs will result in failure of the regulator to control the pressure.

With the vent of a regulator facing down, corrosion products from the springs could clog the regulator vent screen blocking the vent.

Action Required: Regulator inspection for corrosion should be made according to the guidelines listed below:

- For underground installations subject to submersion, the regulator should be inspected **every** time the container is filled.
- For known corrosive atmospheres of salt air or chemical pollution, the regulator should be inspected at least once a year.

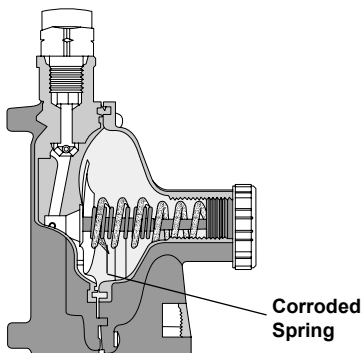

- For other applications, the regulator should be inspected every 3 years. **If any corrosion is evident, replace the regulator.**

It is essential that the regulator bonnet cap be tightly in place at all times to prevent the entrance of water, bugs, dirt, etc. Foreign material can cause the regulator to function improperly with potentially hazardous results.

5. Liquid propane in the regulator:

This can occur on recreational vehicles, unless the regulator is installed substantially higher than the container shut-off valve. Here, sloshing propane could get into the regulator with the resulting high pressure downstream of the regulator. It could also occur on stationary installations if the regulator is installed below the shut-off valve and the container is over-filled.

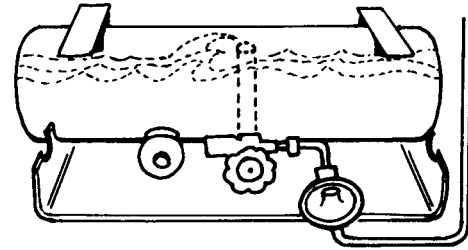

Action Required: Be careful of regulator installation and never overfill any LP-Gas container.

Leaks of LP-Gas to Atmosphere

While the occurrences of leaking regulators are rare, they can and do occur with a potential for fires and explosions.

These leaks can be caused by:

1. Corrosion of the relief valve spring or foreign material on the seat disc which causes the relief valve to open, will cause LP-Gas to escape through the regulator vent, as well as permitting high pressure into the system.

Action Required: Regulator inspection for corrosion should be made according to the guidelines listed below:

- For underground installations subject to submersion, the regulator should be inspected **every** time the container is filled.
- For known corrosive atmospheres of salt air or chemical pollution, the regulator should be inspected at least once a year.
- For other applications, the regulator should be inspected every 3 years.

If any corrosion is evident, replace the regulator.

2. Bad piping connections at the regulator inlet and outlet. This can occur at the time of installation where connections are loose or the regulator may have been overstressed by excessive wrenching. It is important that proper wrenches, both on the piping and on the regulator inlet and outlet, be used when connecting the system piping, and that the regulator die cast body is not cracked by wrenching the pipe too deeply into the body.

Action Required: Always test for leaks at time of installation and inspect for leaks if there is reason to believe that pipe connections could cause a hazard.

Safety Warnings

Loss of Pressure

Freeze-up inside the regulator.

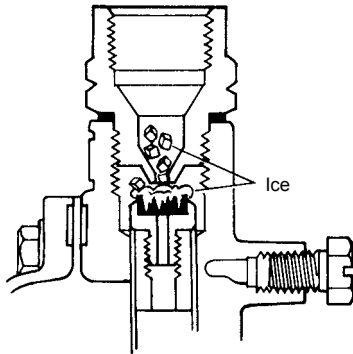

This will prevent the regulator from regulating properly.

Regulator freeze-ups occur because there is excessive moisture in the gas. Freeze-ups can also occur in pigtails that are kinked or bent where free flow of the LP-Gas is restricted. These freeze-ups can occur when the moisture, gas flow and temperature combine to create a hazardous condition. Freeze-ups can occur at temperatures above 32° F.

Action Required: All LP-Gas should be checked for moisture content prior to delivery to consumers and proper amounts of anhydrous methanol added if the gas cannot be returned to the supplier. Any container suspected of having excessive moisture should be treated with the proper amount of methanol.

Underground Installations

Special hazards can occur if regulators are not properly installed in underground systems. Water, dirt, mud and insects can get into the regulator if the bonnet cap is not tightly in place and the vent is not protected with a proper vent tube, opening above any potential water level.

Most problems occur because the waterproof dome on the buried storage tank does not extend above the ground level sufficiently to keep out water and mud.

Refer to NPGA No. 401.

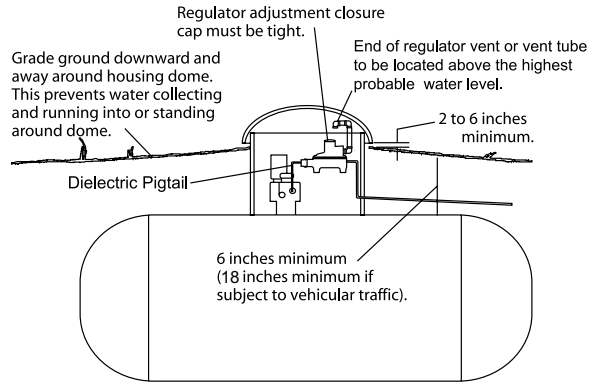

Note: Water mark left in housing dome at level above regulator vent, or end of vent tube requires replacement of regulator. Then correct installation.

Customer Safety

Since regulators are often used by consumers without previous knowledge of the hazards of LP-Gas, and the LP-Gas dealers are the only ones who have direct contact with the consumers,

It is the dealer's responsibility to make sure that his customers are properly instructed in safety matters relating to their installation.

At the very minimum, it is desirable that these customers:

1. Know the odor of LP-Gas and what to do in case they smell gas. Use the NPGA "Scratch 'n Sniff" leaflet.
2. Are instructed to never tamper with the system.
3. Know that when protective hoods are used to enclose regulators and/or valves, that these hoods must be closed, but not locked.
4. Keep snow drifts from covering regulators.
5. Know the location of the cylinder or tank shut-off valve in emergencies.

General Warning

All RegO Products are mechanical devices that will eventually become inoperative due to wear, contaminants, corrosion and aging of components made of materials such as metal and rubber. As a general recommendation, Regulators should be replaced in accordance with all of the recommendations outlined in this safety warning. The recommended service life of a regulator is one of many factors that must be considered in determining when to replace a regulator.

The environment and conditions of use will determine the safe service life of these products. Periodic inspection and maintenance are essential.

Because RegO Products have a long and proven record of quality and service, LP-Gas dealers may forget the hazards that can occur because a regulator is used beyond its safe service life. Life of a regulator is determined by the environment in which it "lives." The LP-Gas dealer knows better than anyone what this environment is.

NOTE: There is a developing trend in state legislation and in proposed national legislation to make the owners of products responsible for replacing products before they reach the end of their safe useful life. LP-Gas dealers should be aware of legislation which could affect them.

Advantages of Two-Stage Regulation

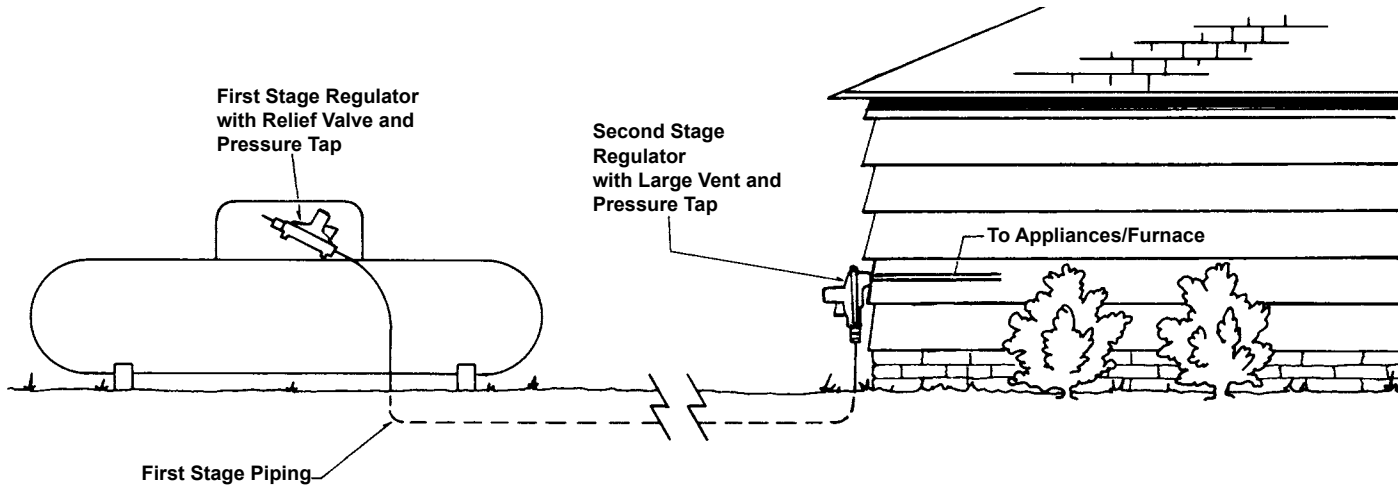

The regulator is truly the heart of an LP-Gas installation. It must compensate for variations in tank pressure from as low as 8 PSIG to 220 PSIG – and still deliver a steady flow of LP-Gas at 11" w.c. to consuming appliances. The regulator must deliver this pressure

despite a variable load from intermittent use of the appliances. Though a single-stage system may perform adequately in many installations, the use of a two-stage system offers the ultimate in pin-point regulation. Two-stage regulation can result in a more profitable LP-Gas operation for the dealer resulting from less maintenance and fewer installation callbacks – and there is no better time than now for installing RegO Regulators in two-stage systems.

Uniform Appliance Pressure

The installation of a two-stage system – one high pressure regulator at the container to compensate for varied inlet pressures, and one low pressure regulator at the building to supply a constant delivery pressure to the appliances – helps ensure maximum efficiency and trouble-free operation year-round. It is important to note that while pressure at the appliances can vary up to 4" w.c. using single-stage systems, two-stage systems keep pressure variations within 1" w.c. New high-efficiency appliances require this closer pressure control for proper ignition and stable, efficient operation. In fact, one major manufacturer requires the use of two-stage systems with their appliances.

Reduced Freeze-ups/Service Calls

Regulator freeze-up occurs when moisture in the gas condenses and freezes on cold surfaces of the regulator nozzle. The nozzle becomes chilled when high pressure gas expands across it into the regulator body. This chilling action is more severe in single-stage systems as gas expands from tank pressure to 11" w.c. through a single regulator nozzle.

Size The System Correctly

Prior to installing your two-stage system, be sure the system pipe and tubing is properly sized. Proper sizing will help ensure constant delivery pressure to the appliances during fluctuating loads at all times. Just as important, be sure the RegO Regulators you choose are capable of handling the desired load. This is another advantage of two-stage systems – they are capable of handling much more BTU's/hr. than single-stage systems. The RegO "LP-Gas Serviceman's Manual" provides complete information on pipe sizing and proper regulator selection.

Two-stage systems can greatly reduce the possibility of freeze-ups and resulting service calls as the expansion of gas from tank pressure to 11" w.c. is divided into two steps, with less chilling effect at each regulator. In addition, after the gas exits the first-stage regulator and enters the first-stage transmission line, it picks up heat from the line, further reducing the possibility of second-stage freeze-up.

Service calls for pilot outages and electronic ignition system failures are also reduced as a result of more uniform appliance pressure from two-stage systems.

Economy of Installation

In a single-stage system, transmission line piping between the container and the appliances must be large enough to accommodate the required volume of gas at 11" w.c. In contrast, the line between the first and second stage regulators in two-stage systems can be much smaller as it delivers gas at 10 PSIG to the second-stage regulator. Often the savings in piping cost will pay for the second regulator.

As an additional benefit, single-stage systems can be easily converted to two-stage systems using existing supply lines when they prove inadequate to meet added loads. This is the least expensive and best method of correcting the problem.

Allowance for Future Appliances

A high degree of flexibility is offered in new installations of two-stage systems. Appliances can be added later to the present load – provided the high pressure regulator can handle the increase – by the addition of a second low pressure regulator. Since appliances can be regulated independently, demands from other parts of the installation will not affect their individual performances.

Replace Pigtails

If you are replacing an old regulator, remember to replace the copper pigtail. The old pigtail may contain corrosion which can restrict flow. In addition, corrosion may flake off and wedge between the regulator orifice and seat disc – preventing proper lock-up.

Two-Stage LP-Gas Systems

Require First Stage Regulators with Built-in Relief Valves

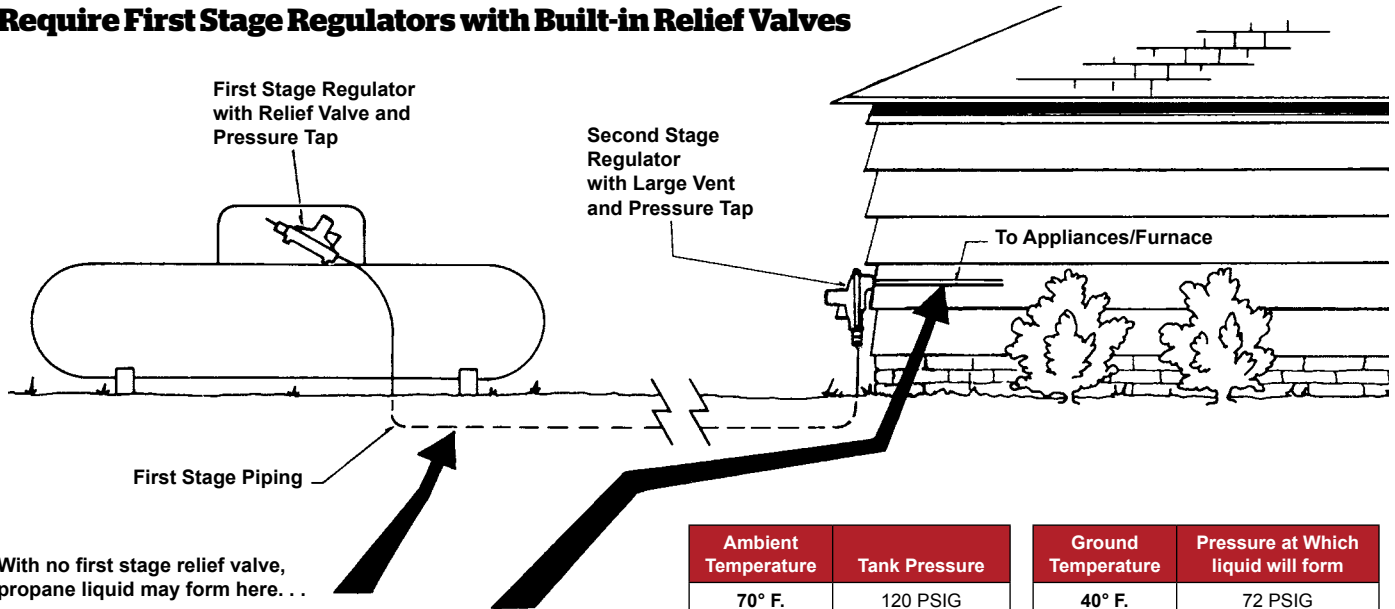

With no first stage relief valve, propane liquid may form here . . .

Resulting in sudden pressure surge due to flashing into vapor here! First stage relief can prevent liquid from forming in first stage piping during periods with no gas demand !!!

Ambient Temperature	Tank Pressure	Ground Temperature	Pressure at Which liquid will form
70° F.	120 PSIG	40° F.	72 PSIG
80° F.	140 PSIG	50° F.	86 PSIG
90° F.	165 PSIG	60° F.	102 PSIG

Pressure at which liquid can form at various temperatures.

Vapor Pressures of LP-Gases

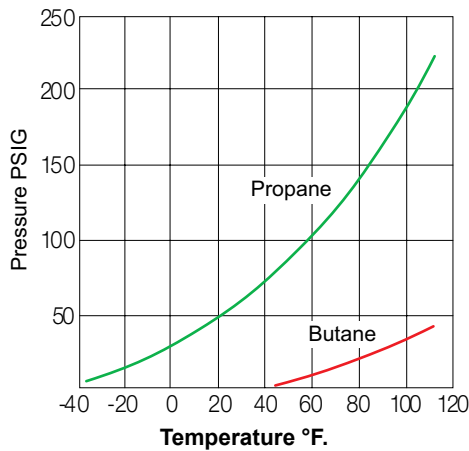

The Problem

Many modern LP-Gas appliances are equipped with pilotless ignition systems. Water heaters and older appliances use pilot lights, but it has become a common practice for energy conscious homeowners to shut-off the pilot when leaving home for extended periods of time. In each instance, there is **no gas demand at all** for extended periods.

The Consequences

If the first stage regulator fails to lock-up tight, usually as a result of a worn seat disc or foreign material lodged between nozzle and seat disc, pressure will build-up in the first stage piping – possibly to a level that approaches tank pressure. Combining this with warm ambient temperatures and cool ground, **propane liquid may form** in the first stage piping.

When gas demand resumes, this liquid may pass through the second stage regulator into the appliances and furnace. NOTE – the second

stage regulator will not relieve the pressure in first stage piping. The rapid vaporization of the liquid may cause a rapid pressure surge that could seriously damage critical components of the appliance and furnace controls.

A fire or explosion could occur as a consequence.

The Solution

RegO LV4403 Series First Stage Regulators with Built-In Relief Valves reduce the possibility of this serious hazard in two stage applications. The built-in relief valve is designed to vent as needed and reduce the possibility of first stage piping pressure from becoming high enough to form liquid.

Pipe and Tubing Selection Guide

Use the following simple method to ensure the selection of the correct sizes of piping and tubing for LP-Gas vapor systems. Piping between the first and second stage is considered, as well as lower pressure (2 PSIG) piping between the 2 PSIG second stage or integral twin stage regulator and the line pressure regulator; and low pressure (inches of water column) piping between second stage, single stage, or integral twin stage regulators and appliances. The information supplied below is from NFPA 54 (National Fuel Gas Code) Appendix C, and NFPA 58 (Liquefied Petroleum Gas Code) Chapter 15; it can also be found in CETP (Certified Employee Training Program) published by the Propane Education and Research Council "Selecting Piping and Tubing" module 4.1.8. These illustrations are for demonstrative purposes, they are not intended for actual system design.

Instructions:

- Determine the total gas demand for the system by adding up the BTU/hr input from the appliance nameplates and adding demand as appropriate for future appliances.
- For second stage or integral twin stage piping:
 - Measure length of piping required from outlet of regulator to the appliance furthest away. *No other length is necessary to do the sizing.*
 - Make a simple sketch of the piping, as shown.
 - Determine the capacity to be handled by each section of piping. For example, the capacity of the line between a and b must handle the total demand of appliances A, B, and C; the capacity of the line from c to d must handle only appliance B, etc.
 - Using Table 3 select proper size of tubing or pipe for each section of piping, using values in BTU/hr for the length determined from step #2-A. If exact length is not on chart, use next longer length. Do not use any other length for this purpose! Simply select the size that shows at least as much capacity as needed for each piping section.
- For piping between first and second stage regulators
 - For a simple system with only one second stage regulator, merely measure length of piping required between outlet of first stage regulator and inlet of second stage regulator. Select piping or tubing required from Table 1.
 - For systems with multiple second stage regulators, measure length of piping required to reach the second stage regulator that is furthest away. Make a simple sketch, and size each leg of piping using Table 1, 2, or 3 using values shown in column corresponding to the length as measured above, same as when handling second stage piping.

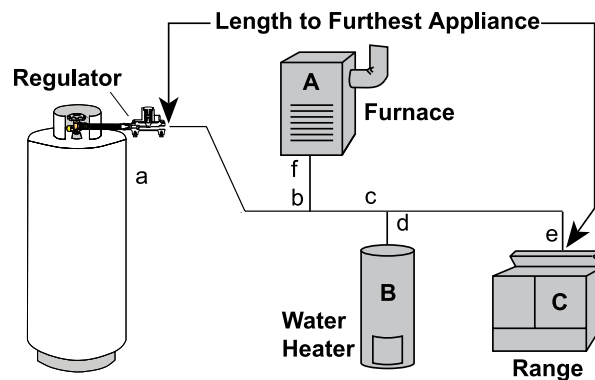

Example 1

Determine the sizes of piping or tubing required for the twin-stage LP-Gas installation shown.

- Total piping length = 84 feet (use Table 3 @90 feet)**
- From a to b, demand = 38,000 + 35,000 + 30,000 = 103,000 BTU/hr; use ¾" pipe or ¾" tubing
- From b to c, demand = 38,000 + 35,000 = 73,000 BTU/hr; use ½" pipe or ½" tubing
- From c to d, demand = 35,000 BTU/hr; use ½" pipe or ½" tubing
- From c to e, demand = 38,000 BTU/hr; use ½" pipe or ½" tubing
- From b to f, demand = 30,000 BTU/hr; use ½" pipe or ½" tubing

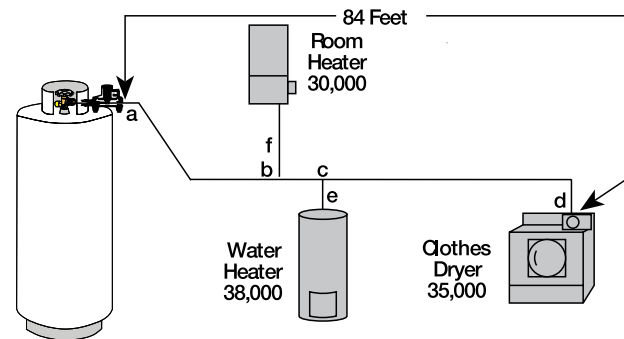

Example 2.

Determine the sizes of piping or tubing required for the two-stage LP-Gas installation shown.

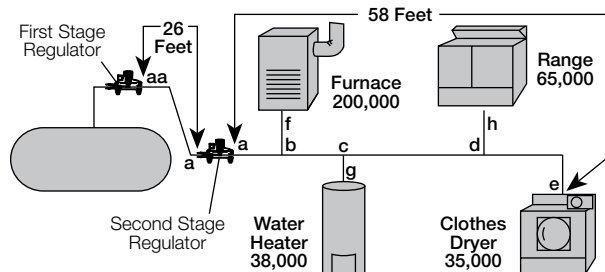

Total first stage piping length = 26 feet; first stage regulator setting is 10 PSIG (use Table 1 or 2 @ 30 feet)

From aa to a, demand = 338,000 BTU/hr; use ½" pipe, ½" tubing, or ½" T plastic pipe.

Total second stage piping length = 58 feet (use Table 3 @ 60 feet)

- From a to b, demand = 338,000 BTU/hr; use 1" pipe
- From b to c, demand = 138,000 BTU/hr; use ¾" pipe or ¾" tubing
- From c to d, demand = 100,000 BTU/hr; use ½" pipe or ½" tubing
- From d to e, demand = 35,000 BTU/hr; use ½" pipe or ½" tubing
- From b to f, demand = 200,000 BTU/hr; use ¾" pipe
- From c to g, demand = 38,000 BTU/hr; use ½" pipe or ½" tubing
- From d to h, demand = 65,000 BTU/hr; use ½" pipe or ½" tubing

Pipe and Tubing Selection Guide

Example 3

Determine the sizes of piping or tubing required for the 2 PSI LP-Gas installation shown.

Total first stage piping length = 26 feet; first stage regulator setting is 10psig (use Table 1 or 2 @ 30 feet)

Total 2 PSI Piping Length = 19 ft. (use Table 4 @ 20 ft. or Table 6 @ 20 ft.)

From aa to a, demand= 338,000 BTU

use ¾" CSST or ½" copper tubing or ½" pipe

From Regulator a to each appliance:

From a to b, demand= 65,000 BTU; length = 25 ft. (Table 5),

use ½" CSST

From a to c, demand= 200,000 BTU; length = 30 ft. (Table 5)

use 1" CSST

From a to d, demand= 38,000 BTU; length = 21 ft.* (Table 5)

use ¾" CSST *use 25 ft. column

From a to e, demand= 35,000 BTU; length = 40 ft. (Table 5)

use ½" CSST

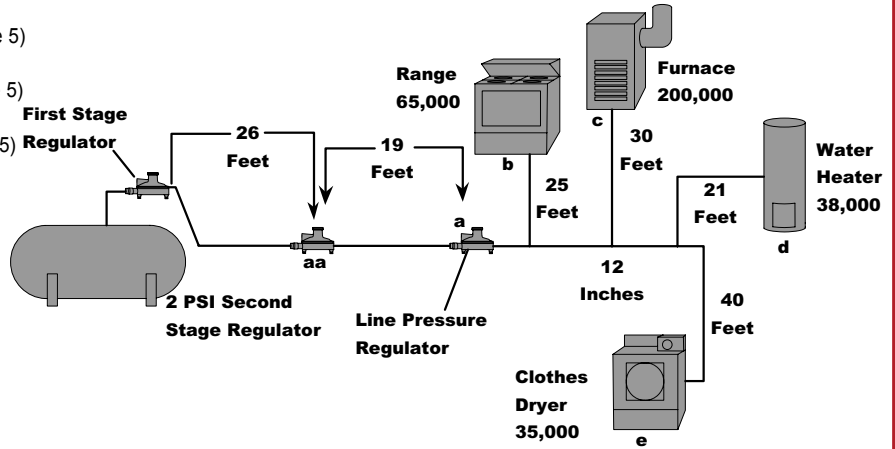

Table 1 - First Stage Tubing or Pipe Sizing * 10 PSIG Inlet with a 1 PSIG Pressure Drop (Between First and Second Stage Regulators)
Maximum capacity of pipe or tubing in thousands of BTU/hr of undiluted LP-Gases (Propane) (Based on 1.50 Specific Gravity Gas)

Size of Pipe or Copper Tubing, Inches		Length of Pipe or Tubing in Feet*																	
		10	20	30	40	50	60	70	80	90	100	125	150	175	200	250	300	350	400
Copper Tubing (O.D.)	¾"	513	352	283	242	215	194	179	166	156	147	131	118	109	101	90	81	75	70
	½"	1,060	727	584	500	443	401	369	343	322	304	270	244	225	209	185	168	155	144
	¾"	2,150	1,480	1,190	1,020	901	816	751	699	655	619	549	497	457	426	377	342	314	292
Pipe Size	¾"	3,760	2,580	2,080	1,780	1,570	1,430	1,310	1,220	1,150	1,080	959	869	799	744	659	597	549	511
	½"	3,320	2,280	1,830	1,570	1,390	1,260	1,160	1,080	1,010	956	848	768	706	657	582	528	486	452
	¾"	6,950	4,780	3,840	3,280	2,910	2,640	2,430	2,260	2,120	2,000	1,770	1,610	1,480	1,370	1,220	1,100	1,020	945
	1"	13,100	9,000	7,229	6,180	5,480	4,970	4,570	4,250	3,990	3,770	3,340	3,020	2,780	2,590	2,290	2,080	1,910	1,780
	1 ¼"	26,900	18,500	14,800	12,700	11,300	10,200	9,380	8,730	8,190	7,730	6,850	6,210	5,710	5,320	4,710	4,270	3,930	3,650
	1 ½"	40,300	27,700	22,200	19,000	16,900	15,300	14,100	13,100	12,300	11,600	10,300	9,300	8,560	7,960	7,060	6,400	5,880	5,470
2"	77,600	53,300	42,800	36,600	32,500	29,400	27,100	25,200	23,600	22,300	19,800	17,900	16,500	15,300	13,600	12,300	11,300	10,500	

* Notes: Total length of piping from outlet of first stage regulator to inlet of second stage regulator (or to inlet of second stage regulator furthest away)

1) To allow 2 PSIG pressure drop, multiply total gas demand by 0.707 and use capacities from table.

2) For different first stage pressures, multiply total gas demand by the following factor and use capacities from table.

Example: 1,000,000 BTU load at 5 PSI: 1,000,000 (1.12) = 1,120,000 BTU then use chart based on 1,120,000 BTU

First Stage Pressure PSIG	Multiply By
20	0.844
15	0.912
5	1.120

Table 2 - First Stage Polyethylene Plastic Tubing or Pipe Sizing *

10 PSIG Inlet with a 1 PSIG Pressure Drop (Between First and Second Stage Regulators)

Maximum capacity of polyethylene pipe or tubing in thousands of BTU/hr of undiluted LP-Gases (Propane)
(Based on 1.50 Specific Gravity Gas)

Size of Plastic Tubing or Pipe		Length of Pipe or Tubing in Feet*																			
		10	20	30	40	50	60	70	80	90	100	125	150	175	200	225	250	275	300	350	400
½ T	7.00			762	653	578	524	482	448	421	397	352	319	294	273	256	242	230	219	202	188
¾	9.33			2,140	1,840	1,630	1,470	1,360	1,260	1,180	1,120	990	897	826	778	721	681	646	617	567	528
1 T	11.00			2,390	3,670	3,260	2,950	2,710	2,530	2,370	2,240	990	897	826	778	721	681	646	617	567	528
1 ¼	11.00			5,230	4,470	3,960	3,590	3,300	3,070	2,880	2,720	2,410	2,190	2,010	1,870	1,760	1,660	1,580	1,500	1,380	1,290
1 ½	11.00			7,740	6,630	5,870	5,320	4,900	4,560	4,270	4,040	3,580	3,240	2,980	2,780	2,600	2,460	2,340	2,230	2,050	1,910
2	11.00			13,420	11,480	10,180	9,220	8,480	7,890	7,400	6,990	6,200	5,620	5,170	4,810	4,510	4,260	4,050	3,860	3,550	3,300
2 ½	11.00			20,300	17,300	15,400	13,900	12,800	11,900	11,200	10,600	9,360	8,480	7,800	7,260	6,810	6,430	6,110	5,830	5,360	4,990
3	11.00			36,400	31,200	27,600	25,000	23,000	21,400	20,100	19,000	16,800	15,200	14,000	13,000	12,200	11,600	11,000	10,470	9,640	8,970

* Note: Total length of piping from outlet of first stage regulator to inlet of second stage regulator (or to inlet of second stage regulator furthest away)

T = Tube Size

First Stage Pressure PSIG	Multiply By
20	0.844
15	0.912
5	1.120

Pipe and Tubing Selection Guide

Table 3 - Second Stage or Integral Twin Stage Tubing or Pipe Sizing *
11-in. Water Column Inlet with a 0.05-in. Water Column Drop

Maximum capacity of pipe or tubing in thousands of BTU/hr of undiluted LP-Gases (Propane) (Based on 1.50 Specific Gravity Gas)

Size of Pipe or Copper Tubing, Inches	Length of Pipe or Tubing in Feet*																	
	10	20	30	40	50	60	70	80	90	100	125	150	175	200	250	300	350	400
Copper Tubing (O.D.)	3/8	45	31	25	21	19	17	16	15	14	13	11	10	NA	NA	NA	NA	NA
	1/2	93	64	51	44	39	35	32	30	28	27	24	21	20	18	16	15	14
	5/8	188	129	104	89	79	71	66	61	57	54	48	44	40	37	33	30	28
	3/4	329	226	182	155	138	125	115	107	100	95	84	76	70	65	58	52	48
Pipe Size	1/2	291	200	160	137	122	110	NA	101	NA	94	89	84	74	67	62	58	51
	3/4	608	418	336	287	255	231	NA	212	NA	197	185	175	155	140	129	120	107
	1	1,150	787	632	541	480	434	NA	400	NA	372	349	330	292	265	243	227	201
	1 1/4	2,350	1,620	1,300	1,110	985	892	NA	821	NA	763	716	677	600	543	500	465	412
	1 1/2	3,520	2,420	1,940	1,660	1,480	1,340	NA	1,230	NA	1,140	1,070	1,010	899	814	749	697	618
	2	6,790	4,660	3,750	3,210	2,840	2,570	NA	2,370	NA	2,200	2,070	1,950	1,730	1,570	1,440	1,340	1,190

* Note: Total length of piping from outlet of regulator to appliance furthest away.

Data Calculated per NFPA # 54 and NFPA # 58

Table 4 - Maximum Capacity of CSST *
2 PSIG and a Pressure Drop of 1 PSIG (Between 2 psig Service and Line Pressure Regulator)

In Thousands of BTU/hr of undiluted LP-Gases (Propane) (Based on 1.50 Specific Gravity Gas)

Size	EDH** Flow Designation	Length of Tubing in Feet*													
		10	25	30	40	50	75	80	100	150	200	250	300	400	500
3/8	13	426	262	238	203	181	147	140	124	101	86	77	69	60	53
	15	558	347	316	271	243	196	189	169	137	118	105	96	82	72
1/2	18	927	591	540	469	420	344	333	298	245	213	191	173	151	135
	19	1,110	701	640	554	496	406	393	350	287	248	222	203	175	158
3/4	23	1,740	1,120	1,030	896	806	663	643	578	477	415	373	343	298	268
	25	2,170	1,380	1,270	1,100	986	809	768	703	575	501	448	411	355	319
1	30	4,100	2,560	2,330	2,010	1,790	1,460	1,410	1,260	1,020	880	785	716	616	550
	31	4,720	2,950	2,690	2,320	2,070	1,690	1,630	1,450	1,180	1,020	910	829	716	638

* Notes:

(1) Table does not include effect of pressure drop across the line regulator. If regulator loss exceeds 1/2 psi (based on 13-in. water column outlet pressure).

(2) **DO NOT USE THIS TABLE.** Consult with regulator manufacturer for pressure drops and capacity factors. Pressure drops across a regulator may vary with flow rate.

(3) **CAUTION:** Capacities shown in table can exceed maximum capacity for a selected regulator. Consult with regulator or tubing manufacturer for guidance.

(4) Table includes losses for four 90-degree bends and two end fittings. Tubing runs with a larger number of bends and/or fittings shall be increased by an equivalent length of tubing according to the following equation; L-1.3n where L is additional length (ft) of tubing and n is the number of additional fittings and/or bends.

**EHD - Equivalent Hydraulic Diameter - A measure of the relative hydraulic efficiency between different tubing sizes. The greater the value of EHD, the greater the gas capacity of the tubing.

Data Calculated per NFPA # 54 and NFPA # 58

Table 5 - Maximum Capacity of CSST *

11-in. Water Column and a Pressure Drop of 0.05-in. Water Column (Between Second Stage (Low Pressure) Regulator and Appliance Shutoff Valve)

In Thousands of BTU/hr of undiluted LP-Gases (Propane)

(Based on 1.50 Specific Gravity Gas)

Size	EDH** Flow Designation	Length of Tubing in Feet*															
		5	10	15	20	25	30	40	50	60	70	80	90	100	150	200	250
3/8	13	72	50	39	34	30	28	23	20	19	17	15	14	11	9	8	8
	15	99	69	55	49	42	39	33	30	26	25	23	22	20	15	14	12
1/2	18	181	129	104	91	82	74	64	58	53	49	45	44	41	31	28	25
	19	211	150	121	106	94	87	74	66	60	57	52	50	47	36	33	30
3/4	23	355	254	208	183	164	151	131	118	107	99	94	90	85	66	60	53
	25	426	303	248	216	192	177	153	137	126	117	109	102	98	75	69	61
1	30	744	521	422	365	325	297	256	227	207	191	178	169	159	123	112	99
	31	863	605	490	425	379	344	297	265	241	222	208	197	186	143	129	117

* Notes:

Table includes losses for four 90-degree bends and two end fittings. Tubing runs with a larger number of bends and/or fittings shall be increased by an equivalent length of tubing according to the following equation; L-1.3n where L is additional length (ft) of tubing and n is the number of additional fittings and/or bends.

**EHD - Equivalent Hydraulic Diameter - A measure of the relative hydraulic efficiency between different tubing sizes. The greater the value of EHD, the greater the gas capacity of the tubing.

Data Calculated per NFPA # 54 and NFPA # 58

Table 6 - Copper Tubing or Schedule 40 Pipe Sizing *

2 PSIG Inlet with a 1 PSIG Pressure Drop (Between 2 PSIG Service and Line Pressure Regulator)

In Thousands of BTU/hr of undiluted LP-Gases (Propane) (Based on 1.50 Specific Gravity Gas)

Size of Pipe or Copper Tubing, Inches	Length of Pipe or Tubing in Feet*																								
	10	20	30	40	50	60	70	80	90	100	125	150	175	200	250	300	350	400	450	500	550	600	650	700	
Copper Tubing (O.D.)	3/8	413	284	228	195	173	157	144	134	126	119	105	95	88	82	72	66	60	56	53	50	47	45	43	41
	1/2	852	585	470	402	356	323	297	276	259	245	217	197	181	168	149	135	124	116	109	103	97	93	89	86
	5/8	1,730	1,190	956	818	725	657	605	562	528	498	442	400	368	343	304	275	253	235	221	209	198	189	181	174
	3/4	3,030	2,080	1,670	1,430	1,270	1,150	1,060	983	922	871	772	700	644	599	531	481	442	411	386	365	346	330	316	304
Pipe Size	1/2	2,680	1,840	1,480	1,260	1,120	1,010	934	869	815	770	682	618	569	529	469	425	391	364	341	322	306	292	280	269
	3/4	5,590	3,850	3,090	2,640	2,340	2,120	1,950	1,820	1,700	1,610	1,430	1,290	1,190	1,110	981	889	817	760	714	674	640	611	585	562
	1	10,500	7,240	5,820	4,980	4,410	4,000	3,680	3,420	3,210	3,030	2,690	2,440	2,240	2,080	1,850	1,670	1,540	1,430	1,350	1,270	1,210	1,150	1,100	1,060
	1 1/4	21,600	14,900	11,900	10,200	9,060	8,210	7,550	7,020	6,590	6,230	5,250	5,000	4,600	4,280	3,790	3,440	3,160	2,940	2,760	2,610	2,480	2,360	2,260	2,170
	1 1/2	32,400	22,300	17,900	15,300	13,600	12,300	11,300	10,500	9,880	9,330	8,270	7,490	6,890	6,410	5,680	5,150	4,740	4,410	4,130	3,910	3,710	3,540	3,390	3,260
	2	62,400	42,900	34,500	29,500	26,100	23,700	21,800	20,300	19,000	18,000	15,900	14,400	13,300	12,300	10,900	9,920	9,120	8,490	7,960	7,520	7,140	6,820	6,530	6,270

* Note: Maximum undiluted propane capacities listed are based on a 2-psig setting and a 1-psi pressure drop. Capacities in 1000 BTU/hr.

Data Calculated per NFPA # 54 and NFPA # 58

RegO Regulator Designs

RegO LP-Gas Regulators have been designed to give outstanding performance and dependability with a minimum of maintenance.

Nozzle Orifice

Replaceable and precision machined to prevent scoring of the seat disc.

Seat Disc

Replaceable, resilient construction gives sure closing at lock up pressure. Straight line seat disc to nozzle operation provides even seat disc wear and positive lock up.

Pivot Pin

Fully enclosed in regulator body.

Control Linkage

Provides quick response to diaphragm movement; moves directly perpendicular to nozzle orifice to meter gas flow, gives positive closure and reduces seat disc wear.

Built-In Pressure Tap

Provides a convenient way to check downstream pressure on both high and low pressure models.

Body & Bonnet

Painted, heavy-duty zinc resists corrosion and gives long-life protection, even under "salty air" conditions.

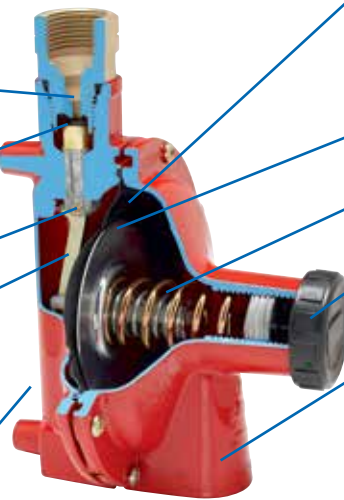

Molded Diaphragm Assembly

Molded synthetic rubber with a tough, flexible fabric gives a super sensitive response in a temperature range of -40° to +165°F. Molded diaphragm seals in a groove between the body and bonnet.

Diaphragm Plate

Rigid diaphragm plate transmits pressure variations to control linkage.

Relief Valve

It is built in and tamper resistant. Large bonnet vent allows high capacity relief on second stage regulators.

Bonnet Cap

Bonnet cap incorporates travel stop to help control downstream pressure in the unlikely event of a regulator malfunction.

Large Bonnet Vent

Large vent is equipped with protective screen and threaded for 3/4" F. NPT vent piping. Large vent helps prevent ice from building up and blocking the vent during inclement weather. The regulator should be installed with vent down and the vent protected against blockage.



Laser Engraved Bonnet

New bonnet design features laser- engraved information that is easy to see and matches available stickers for gas check and record keeping. *Patent Pending

Easy to Turn Adjusting Screw

We redesigned our adjusting screw to be easily turned.

1/8" pressure plug ports

Our 1/8" pressure plug ports conform to 7/16" hex wrenches.

Typical of the 1580 Industrial High Pressure Regulators

The pounds-to-pounds, industrial regulator gives higher delivery pressure as tank pressure decreases, thus permitting full use of the gas in the tank. Most units are field adjustable to meet changing conditions.

Connections

Machined and threaded into the body forging; also includes 1/4" NPT pressure gauge ports.

Seat Disc

Synthetic rubber assembly attached directly to the diaphragm assembly to ensure proper movement and regulation.

Back Cap Spring

Provides added upward force to help provide a positive lock-up.

Sensitivity

In those cases where there is a choice of delivery pressure ranges, the **lowest** spring range which will fulfill your requirements is recommended because the sensitivity of a regulator decreases as the range of the adjusting spring increases.

Relief Valves

Most high pressure regulators are not equipped with integral relief valves. For certain applications where it is desirable to protect equipment downstream of the regulator, relief valves must be installed in the line.

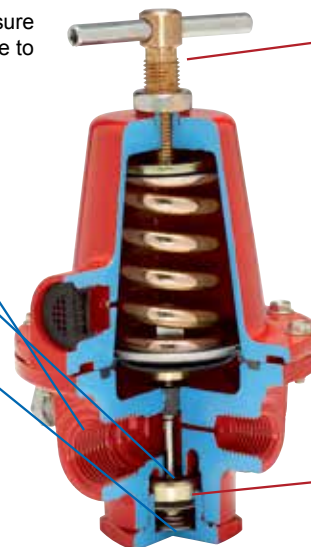

Adjusting Assembly

Large handle with lock-nut release allows easy resetting of delivery pressure.

Integral O-Ring

Minimizes tendency to vibrate or hum under extreme loads.

Compact First Stage Regulators LV3403TR

Application

Ideal for use as a first stage regulator on any domestic size ASME or DOT container in propane gas installations requiring up to 1,500,000 BTU's per hour. The regulator is factory set to reduce container pressure to an intermediate pressure of approximately 10 PSIG.

Features

- Compact design can be connected to a service valve using either a POL adapter or a RegO product pigtail.
- Large threaded 3/8" F.NPT bonnet vent can easily be piped-away underground installations without the need of glue kits or extra adapters.
- Non Adjustable
- Large flow orifice resists freeze ups due to water concentration in LPG vapor.
- Design provides for good flow regulation at both high and low container pressures.
- Built in relief valve and travel stop comply with NFPA 58 over pressure requirements.
- Incorporates 1/8" F.NPT downstream pressure tap for an easy inline check of the regulator's delivery pressure.
- Molded diaphragm provides an o-ring type seal between the body and bonnet.
- Body and bonnet are assembled in the USA using the unique, patented RegUlok seal system.
- Fully painted in brilliant red for complete corrosion protection.
- Mounting bracket available as an accessory: part number 2302-31.

Materials

Body Zinc
 Bonnet Zinc
 Spring Steel
 Seat Disc Resilient Rubber
 Diaphragm Integrated Fabric and Synthetic Rubber



LV3403TR

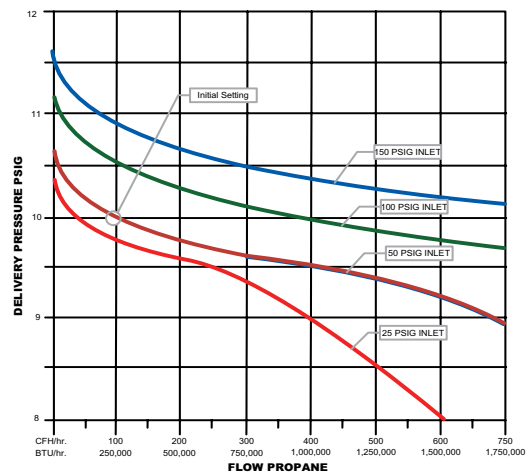
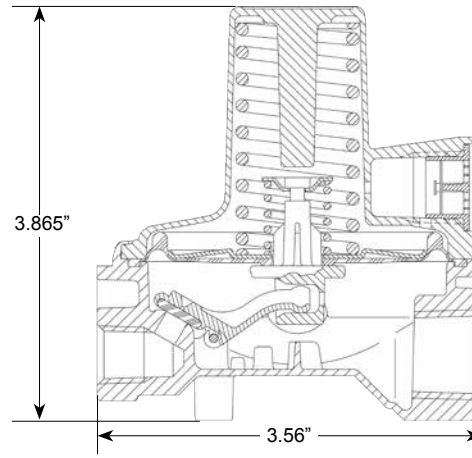

Ordering Information

Part Number	Inlet Connection	Outlet Connection	Orifice Size	Factory Delivery Pressure	Bonnet Vent Position	Vapor Capacity BTU/hr Propane*
LV3403TR	1/4" F.NPT	1/2" F.NPT	7/32"	10 PSIG	Over Outlet	1,500,000
LV3403TRV9					9:00	

* Maximum flow based on inlet pressure 20 PSIG higher than the regulator setting and delivery pressure 20% lower than the regulator setting and delivery pressure 20% lower than the setting.



High Pressure First Stage Regulators LV4403SR and TR Series

Application

Provides accurate first stage regulation in two-stage bulk tank systems. Reduce tank pressure to an intermediate pressure of 5 to 10 PSIG. Also used to supply high pressure burners for applications like industrial furnaces or boilers. Also incorporated in multiple cylinder installations.

Features

- Incorporate integral relief valves for added system protection.
- Large vent helps prevent blockage and has 3/4" F.NPT thread for vent piping.
- Bonnet vent positioned over outlet to avoid icing and contamination by foreign material.
- Unique bonnet vent profile designed to minimize vent freeze over when properly installed.
- Replaceable valve orifice and valve seat disc.
- Straight-line valve closure reduces wear on seat disc.
- Large molded diaphragm is extra sensitive to pressure changes.
- Built in pressure tap has plugged 1/8" F.NPT outlet.
- Plug can be removed with a 3/16" hex allen wrench.
- Extra long lever arm provides uniform delivery pressure.
- Brilliant red finish.

Materials

Body Die Cast Zinc
 Bonnet Die Cast Zinc
 Nozzle Orifice Brass
 Spring Steel
 Valve Seat Disc Resilient Rubber
 Diaphragm Integrated Fabric and Synthetic Rubber



LV4403Series

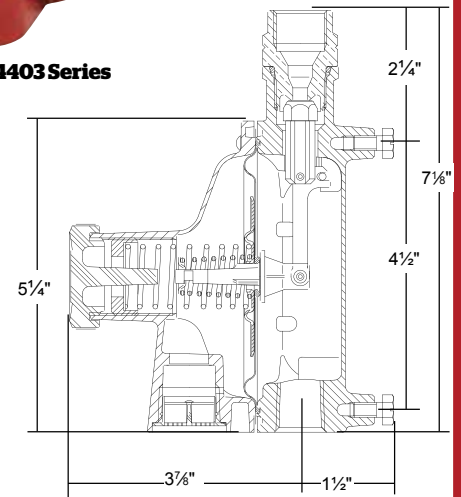

LV4403SR

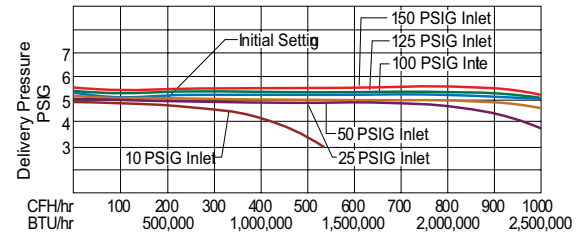

LV4403TR

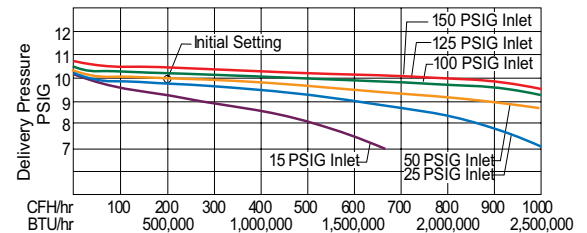

Ordering Information

Part Number	Inlet Connection	Outlet Connection	Orifice Size	Factory Delivery Pressure	Adjustment Range* (PSIG)	Integral Relief Included	Vapor Capacity BTU/hr Propane**
LV4403SR4	1/2" F. NPT	1/2" F. NPT	1/4"	5	1-5	Yes	2,500,000
LV4403TR4				10	5-10		
LV4403SR9				5	1-5		
LV4403TR9	10	5-10					
LV4403SR96	F. POL	3/4" F.NPT		5	1-5		
LV4403TR96				10	5-10		

* When used for final stage pressure control, must either incorporate integral relief valve or separate relief valve should be specified in accordance with NFPA Pamphlet 58.

** Maximum flow based on inlet pressure 20 PSIG higher than the regulator setting and delivery pressure 20% lower than the setting.

Low Pressure Second Stage Regulators - Standard Settings

LV4403B Series

Application

Designed to reduce first stage pressure of 5 to 20 PSIG down to burner pressure, normally 11" w.c. Ideal for medium commercial installations, multiple cylinder installations and normal domestic loads.

Features

- Large vent helps prevent blockage and has 1/2" F.NPT for vent piping.
- With 15 PSIG inlet pressure, regulator is designed to not pass more than 2 PSIG with the seat disc removed.
- Incorporates integral relief valves.
- Replaceable valve orifice and valve seat disc.
- Straight line valve closure reduces wear on seat disc.
- Unique bonnet vent profile minimizes vent freeze over when properly installed.
- Large molded diaphragm is extra sensitive to pressure changes.
- Built in pressure tap has plugged 1/8" F.NPT outlet. Plug can be removed with a 3/16" hex allen wrench.
- Select brown finish.

Backmount Design

Mounts directly to house line piping. Eliminates need for union joints, elbows, and mounting brackets. Quick and easy to install.

Materials

Body Die Cast Zinc
 Bonnet Die Cast Zinc
 Nozzle Orifice Brass
 Spring Steel
 Valve Seat Disc Resilient Rubber
 Diaphragm Integrated Fabric and Synthetic Rubber



LV4403B Series

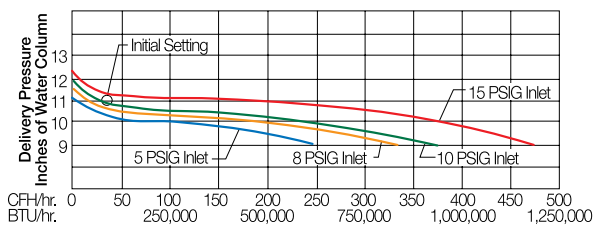
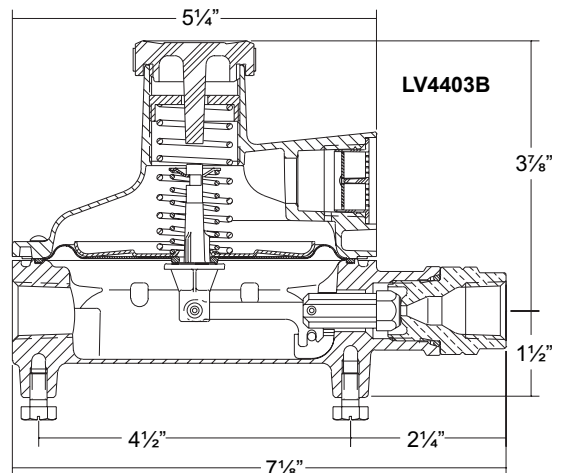
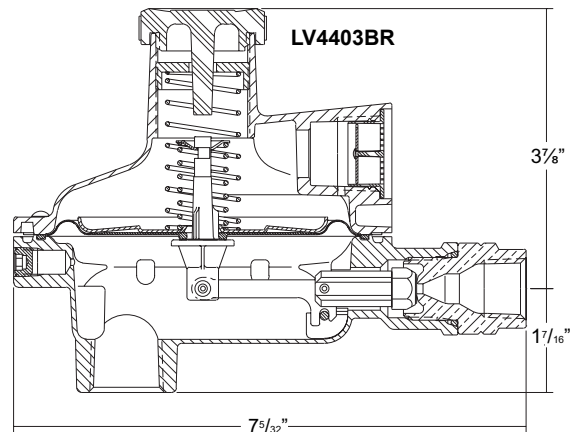

Ordering Information

Part Number	Inlet Connection	Outlet Connection	Orifice Size	Factory Delivery Pressure	Adjustment Range	Bonnet Vent Position	Vapor Capacity BTU/hr. Propane**
LV4403B4	1/2" F. NPT	1/2"	#28 Drill	11" w.c. at 10 PSIG Inlet	9" to 13" w.c.	Over Inlet	935,000
LV4403B46		3/4" F. NPT					
LV4403B46R*							
LV4403B66	3/4" F. NPT	3/4" F. NPT	#28 Drill	11" w.c. at 10 PSIG Inlet	9" to 13" w.c.	Over Inlet	935,000
LV4403B66R*							

* Backmount design

** Maximum flow based on 10 PSIG inlet and 9" w.c. delivery pressure.

New - Dielectric Second Stage Regulators LV4403BD Series

Application

RegO's Dielectric second stage regulators are designed to reduce first stage pressure normally 10PSIG down to burner pressure, normally 11" w.c. and are ideal for medium commercial installations, multiple cylinders installations and normal domestic loads.

RegO Dielectric second stage regulators are engineered to isolate potential electrical current from metallic piping before entering a building. The use of a separate dielectric union is not necessary because the regulator contains a dielectric union as part of the inlet assembly. Available in both SAE Flare and F.NPT inlet connection.

Features

- F. NPT Dielectric Union is made of Brass with inlet Portion Made of Plated Steel
- M. SAE Flare inlet connection made of solid Brass
- All second stage features are the same as LV4403B Series

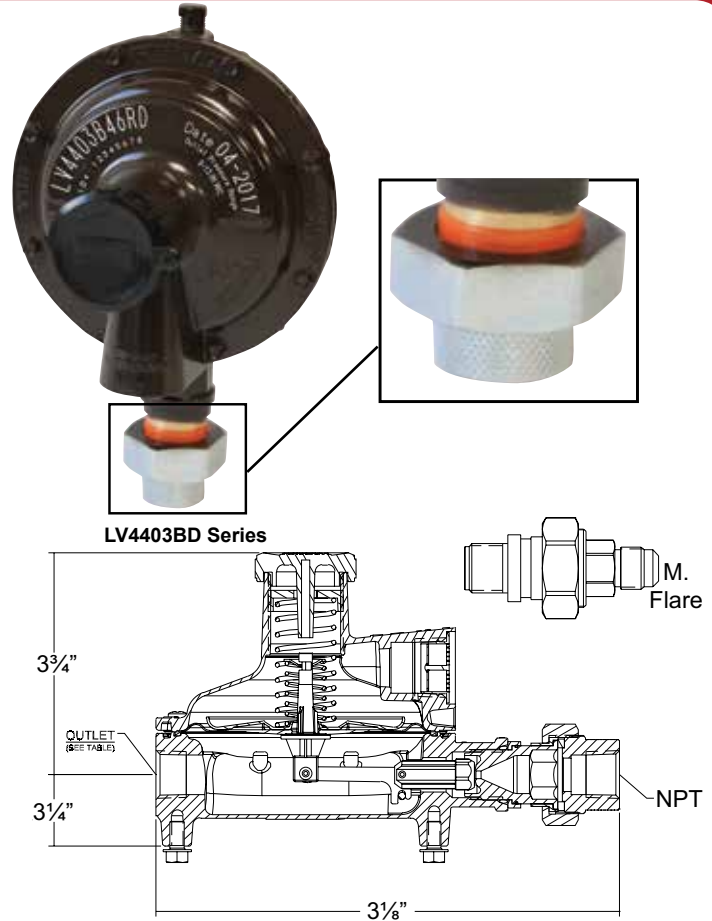

Ordering Information

Part Number	Inlet Connection	Outlet Connection	Inlet Material	Orifice Size	Factory Delivery Pressure	Adjustment Range	Bonnet Vent Position	Vapor Capacity BTU/hr Propane
3/8" M. Flare = 3								
LV4403B3D	3/8" M Flare	1/2" F. NPT	Brass	# 28 Drill	11" w.c. at 10 PSIG Inlet	9" to 13" w.c.	Over Inlet	935,000
LV4403B36D		3/4" F. NPT						
LV4403B3RD*		1/2" F. NPT						
LV4403B36RAD**		3/4" F. NPT						
LV4403B36RABD***		3/4" F. NPT						
1/2" M. Flare = 1								
LV4403B1D	1/2" M Flare	1/2" F. NPT	Brass	# 28 Drill	11" w.c. at 10 PSIG Inlet	9" to 13" w.c.	Over Inlet	935,000
LV4403B16D		3/4" F. NPT						
LV4403B16RD*		3/4" F. NPT						
LV4403B16RAD**		3/4" F. NPT						
LV4403B16RABD***		3/4" F. NPT						
5/8" M. Flare = 5								
LV4403B5D	5/8" M Flare	1/2" F. NPT	Brass	# 28 Drill	11" w.c. at 10 PSIG Inlet	9" to 13" w.c.	Over Inlet	935,000
LV4403B56D		3/4" F. NPT						
LV4403B56RD*		3/4" F. NPT						
LV4403B56RAD**		3/4" F. NPT						
LV4403B56RABD***		3/4" F. NPT						
1/2" - 3/4" F. NPT Female Union								
LV4403B4D	1/2" F. NPT	1/2" F. NPT	Brass & Plated Steel	# 28 Drill	11" w.c. at 10 PSIG Inlet	9" to 13" w.c.	Over Inlet	935,000
LV4403B46D	3/4" F. NPT	3/4" F. NPT						
LV4403B66D	1/2" F. NPT							
LV4403B46RD*	3/4" F. NPT							
LV4403B66RD*	3/4" F. NPT							
LV4403B66RAD**	3/4" F. NPT							
LV4403B66RABD***	3/4" F. NPT	3/4" F. NPT						

* Backmount Design.

** Right Angle Design

***Right Angle with Bracket

Maximum flow based on 10 PSIG inlet and 9" w.c. delivery pressure.

Low Pressure Second Stage Regulators - Special Settings LV4403H Series

Application

Designed to reduce first stage pressure of 5 to 10 PSIG down to pressure higher than 11" water column, the actual pressure setting is specified in the table below. These regulators are designed for installations where the appliances require pressures greater than 11 inches w.c.

Features

- Large vent helps prevent blockage and has 3/4" F.NPT for vent piping.
- With 15 PSIG inlet pressure, regulator is designed to not pass more than 2 PSIG with the seat disc removed.
- Incorporates integral relief valves.
- Replaceable valve orifice and valve seat disc.
- Straight line valve closure reduces wear on seat disc.
- Unique bonnet vent profile minimizes vent freeze over when properly installed.
- Large molded diaphragm is extra sensitive to pressure changes.
- Built in pressure tap has plugged 1/8" F.NPT outlet. Plug can be removed with a 3/16" hex allen wrench.
- Select brown finish.

Materials

Body Die Cast Zinc
 Bonnet Die Cast Zinc
 Nozzle Orifice Brass
 Spring Steel
 Valve Seat Disc Resilient Rubber
 Diaphragm Integrated Fabric and Synthetic Rubber



LV4403H Series

LV4403H

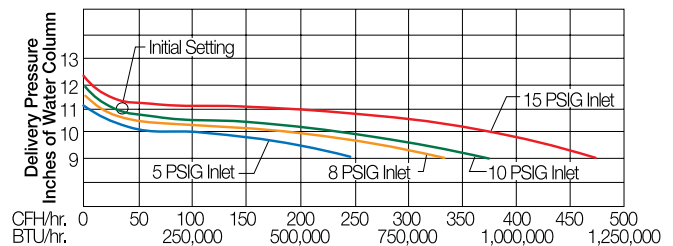
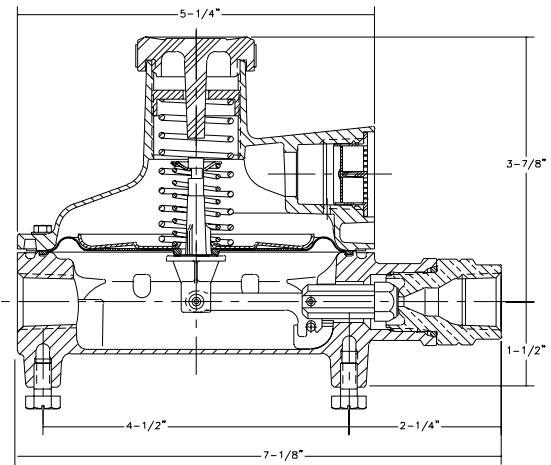

Ordering Information

Part Number	Inlet Connection	Outlet Connection	Orifice Size	Delivery Pressure at 10 PSIG Inlet	Adjustment Range Inches w.c.	Bonnet Vent Position	Vapor Capacity BTU/hr. Propane**
LV4403H222	1/4" F.NPT	1/2" F.NPT	#28	22" w.c.	15-35	Inlet	700,000
LV4403H414	1/2" F.NPT			14" w.c.	12.5-19		
LV4403H420				20" w.c.	15-35		
LV4403H4614		14" w.c.	12.5-19				
LV4403H4620		20" w.c.	15-35				
LV4403H6614	3/4" F.NPT	1/4" F.NPT	14" w.c.	12.5-19			

* Maximum flow based on 10 PSIG inlet 20% drop in delivery pressure (5/1/08)

New Compact “Back-Mount” Regulator LV3403BR Series

Application

The LV3403BR Back Mount Regulator is designed to reduce first stage pressure of 5-10 PSIG down to burner pressure normally 11” w.c. Designed as a second stage regulator for smaller applications with flow requirements up to 450,000 BTU/hr. and are ideal for homes, mobile homes, and cottages.

Features

- Built in 1/8” F.NPT pressure taps on both regulator inlet and outlet side of the regulator. Plugs can be removed with a 3/16” hex allen wrench.
- Large vent helps prevent vent blockage, it is tapped for 3/8” F.NPT for vent pipe away applications.
- With 15 PSIG inlet pressure, the regulator is designed to not pass more than 2 PSIG downstream with the seat disc removed per UL 144 specifications.
- Incorporates an integral relief valve per UL 144 specifications.
- Unique bonnet vent profile minimizes vent freeze over.
- Compact design saves space.



LV3403BR Series

Materials

BodyZinc
 BonnetZinc
 Spring Steel
 Seat Disc Resilient Rubber
 Diaphragm Integrated Fabric and Synthetic Rubber

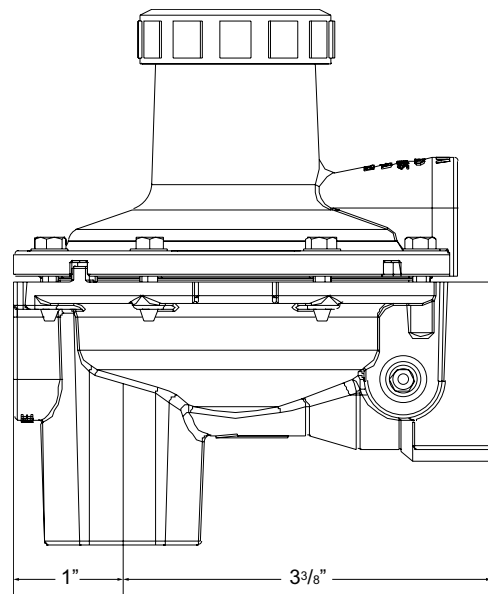

Ordering Information

Part Number	Inlet Connection	Outlet Connection	Orifice Size	Factory Delivery Pressure	Adjustment Range	Bonnet Vent Position	Vapor Capacity BTU/hr *
LV3403B44R	1/2” F.NPT	1/2” F.NPT	7/32”	11” w.c. At 10 PSIG Inlet	9” to 13” w.c.	Over Inlet	450,000
LV3403B46R		3/4” F.NPT					

* Maximum flow based on 10 PSIG inlet and 9” w.c. delivery pressure.

Compact Second Stage Regulator for LP-Gas LV3403B4

Application

The LV3403B4 is designed to reduce first stage pressure of 5-20 PSIG down to burner pressure normally 11" w.c. Designed as a second stage regulator for smaller applications with flow requirements up to 450,000 BTU's/hr, they are ideal for homes, mobile homes, and cottages.



Features

- Large vent helps prevent vent blockage, it is tapped for 3/8" F.NPT for vent piping.
- With 15 PSIG inlet pressure, the regulator is designed to not pass more than 2 PSIG downstream with the seat disc removed, per NFPA 58.
- Incorporates an integral relief valve
- Unique bonnet vent profile minimizes vent freeze over when properly installed.
- Compact design saves space.
- Built in pressure taps 1/8" F.NPT on both regulator inlet and downstream side of the regulator. Plugs can be removed with a 3/16" hex Allen wrench.
- Select brown finish.



LV3403B4 Series

Straight Through Design

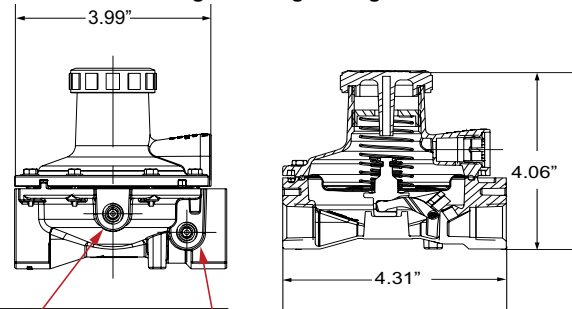

- Downstream Pressure Tap
- Inlet Pressure Tap 1/8" F.NPT

Materials

BodyZinc
 BonnetZinc
 Spring Steel
 Seat Disc Resilient Rubber
 Diaphragm Integrated Fabric and Synthetic Rubber

LV3403B Series

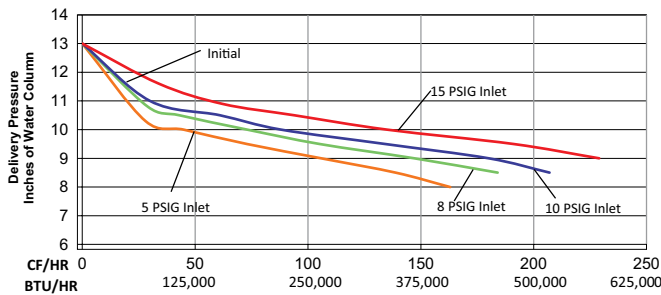

Ordering Information

Part Number	Inlet Connection	Outlet Connection	Orifice Size	Factory Delivery Pressure	Adjustment Range	Bonnet Vent Position	Vapor Capacity BTU/hr *
LV3403B4	1/2" F.NPT	1/2" F.NPT	7/32"	11" w.c. At 10 PSIG Inlet	9" to 13" w.c.	Inlet	450,000
LV3403B4V3						3:00	
LV3403B4V0						Outlet	
LV3403B4V9						9:00	

* Maximum flow based on 10 PSIG Inlet 9" w.c. delivery pressure

Low Pressure Second Stage Regulators LV4403B66RA Series

Application

Designed to reduce first stage pressure of 5 to 20 PSIG down to burner pressure, normally 11" w.c. Ideal for medium commercial installations, vapor meter installations and normal domestic loads.

Features

- 90 degree right angle inlet to outer connection for meter or standard installations.
- Large vent helps to prevent blockage and has 3/4" F. NPT for vent piping.
- With 15 PSIG inlet pressure, regulator is designed to not pass more than 2 PSIG with the seat disc removed.
- Replaceable valve orifice and valve seat.
- Straight line valve closure reduces wear on seat disc
- Unique bonnet vent profile minimizes vent freeze over when properly installed.
- Large molded diaphragm is extra sensitive to pressure changes.
- Built in pressure tap has plugged 1/8" F. NPT outlet. Plug can be removed with a 3/16" hex allen wrench.
- Select Brown Finish

Right Angle Design

Can mount directly to vapor meter. It is also suitable for mounting directly to the house piping. It will retrofit into existing installations that are currently using a 90 degree, right angle regulator.

Materials

Body	Die Cast Zinc
Bonnet	Die Cast Zinc
Nozzle Orifice	Brass
Spring	Steel
Valve Seat Disc	Resilient Rubber
Diaphragm	Integrated Fabric and Synthetic Rubber



LV4403B66RA Series



Attached to Vapor Meter



w/ Mounting Bracket

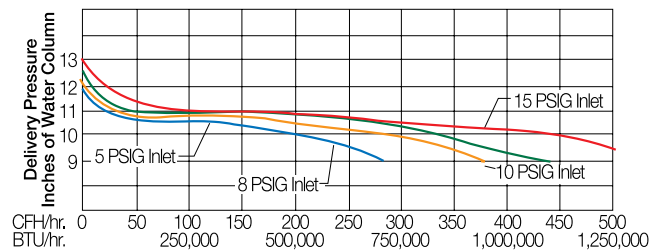
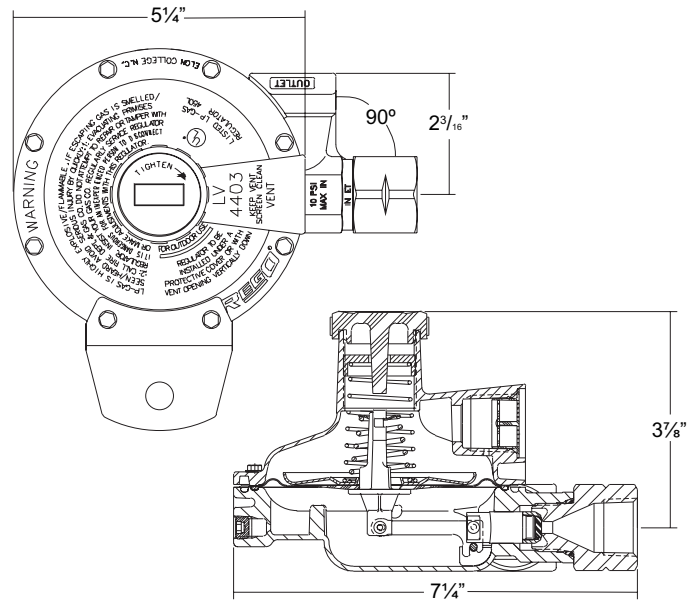

Ordering Information

Part Number	Inlet Connection	Outlet Connection	Orifice Size	Factory Delivery Pressure	Adjustment Range	Bonnet Vent Position	Vapor Capacity BTU/hr. Propane*
LV4403B66RA	3/4" F. NPT	3/4" F. NPT	3/16"	11" w.c. at 10 PSIG Inlet	9" to 13" w.c.	Over Inlet	1,000,000
LV4403B66RAB**							

* Maximum flow is based on 10 PSIG inlet and 9" w.c. delivery pressure.

** Mounting Bracket Included.

Low Pressure Second Stage Regulators - Standard Settings

LV5503B Series

Application

Designed to reduce first stage pressure of 5 to 20 PSIG down to burner pressure, normally 11" w.c. Ideal for larger commercial and industrial applications, multiple cylinder installations and large domestic systems.



LV5503B Series

Features

- Incorporates integral relief valve.
- With 15 PSIG inlet pressure, regulator is designed to not pass more than 2 PSIG with the seat disc removed.
- Replaceable valve orifice and valve seat disc.
- Straight line valve closure saves wear on seat disc and orifice.
- Built in pressure tap has plugged 1/8" F.NPT outlet. Plug can be removed with a 3/16" hex allen wrench.
- Large bonnet vent profile minimizes vent freeze over when properly installed.
- Extra long lever arm for uniform delivery pressure.
- Large diaphragm is extra sensitive to pressure changes.

Materials

Body (LV5503B Series)	Die Cast Aluminum
Bonnet (LV5503B Series)	Die Cast Aluminum
Nozzle Orifice	Brass
Spring	Steel
Valve Seat Disc	Resilient Rubber
Diaphragm	Integrated Fabric and Synthetic Rubber

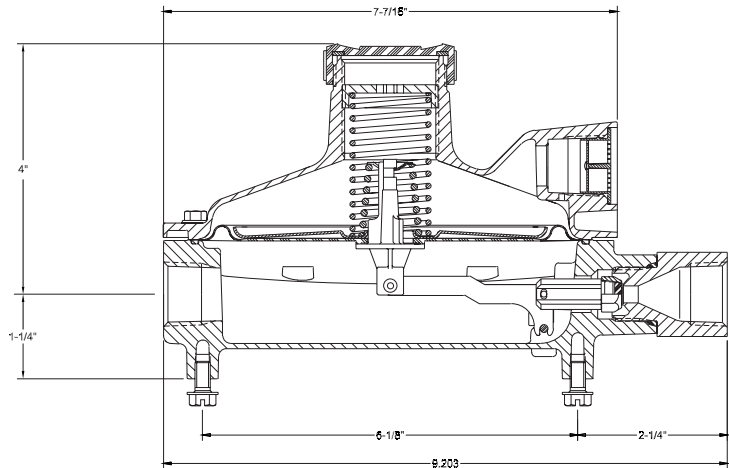

LV5503B4, LV5503B6

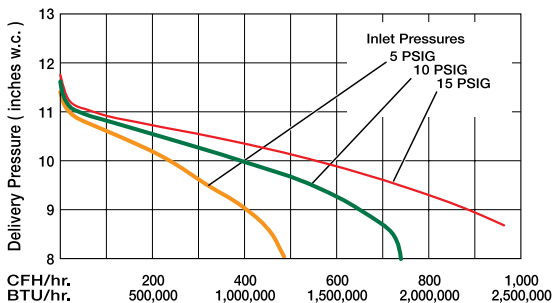

LV5503B8

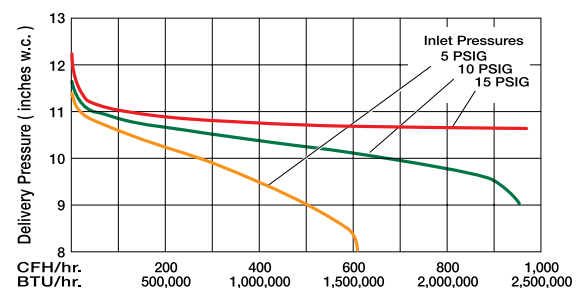

Ordering Information

Part Number	Inlet Connection	Outlet Connection	Orifice Size	Factory Delivery Pressure	Adjustment Range	Bonnet Vent Position	Vapor Capacity BTU/hr. Propane
LV5503B4	1/2" F. NPT	3/4" F. NPT	1/4"	11" w.c. at 10 PSIG Inlet	9" - 13" w.c.	Over Inlet	1,600,000
LV5503B6	3/4" F. NPT						
LV5503B8		1" F. NPT	9/32"				2,300,000

Maximum flow is based on 10 PSIG inlet and 9" w.c. delivery pressure.

Low Pressure Second Stage Regulators - Special Settings

LV5503H Series

Application

Designed to reduce first stage pressure of 5 to 20 PSIG down to burner pressure, normally 11" w.c. Ideal for larger commercial and industrial applications, multiple cylinder installations and large domestic systems.



Features

- Incorporates integral relief valve.
- With 15 PSIG inlet pressure, regulator is designed to not pass more than 2 PSIG with the seat disc removed.
- Replaceable valve orifice and valve seat disc.
- Straight line valve closure saves wear on seat disc and orifice.
- Built in pressure tap has plugged $\frac{1}{8}$ " F.NPT outlet. Plug can be removed with a $\frac{3}{16}$ " hex allen wrench.
- Large bonnet vent profile minimizes vent freeze over when properly installed.
- Extra long lever arm for uniform delivery pressure.
- Large diaphragm is extra sensitive to pressure changes.



LV5503H Series

Materials

Body Die Cast Aluminum
 Bonnet Die Cast Aluminum
 Nozzle Orifice Brass
 Spring Steel
 Valve Seat Disc Resilient Rubber
 Diaphragm Integrated Fabric and Synthetic Rubber

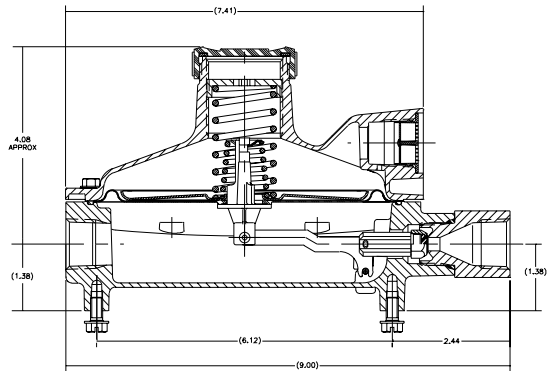

Ordering Information

Part Number	Inlet Connection	Outlet Connection	Orifice Size	Factory Delivery Pressure @ 10 PSIG Inlet	Adjustment Range Inches w.c.	Bonnet Vent Position	Vapor Capacity BTU/hr.* Propane
LV5503H414	$\frac{1}{2}$ " F. NPT	$\frac{3}{4}$ " F. NPT	$\frac{1}{4}$ "	14" w.c.	7-16	Inlet	1,600,000
LV5503H614				20" w.c.	11-28	Outlet	
LV5503H620				40" w.c.	28-84	Inlet	
LV5503H620V		Outlet					
LV5503H640		Inlet					
LV5503H640V		Outlet					
LV5503H814	$\frac{3}{4}$ " F. NPT	1" F. NPT	$\frac{9}{32}$ "	14" w.c.	7-16	Inlet	2,300,000
LV5503H820				20" w.c.	11-28		
LV5503H840				40" w.c.	28-84		

Maximum flow is based on 10 PSIG inlet 20% drop in delivery pressure (5/1/08)

Second Stage Regulators for 2 PSI Systems

LV4403Y and LV5503Y Series

Application

Designed to reduce first stage pressure of 10 PSIG down to 2 PSIG. A line pressure regulator is required downstream to reduce the 2 PSIG to a nominal 11" w.c.

Features

- Large vent helps prevent blockage and has 3/4" F.NPT for vent piping.
- With 15 PSIG inlet pressure, regulator is designed to not pass more than 5 PSIG with the seat disc removed.
- Incorporates an integral relief valve.
- Replaceable valve orifice and valve seat disc.
- Straight line valve closure reduces wear on seat disc.
- Unique bonnet vent profile minimizes vent freeze over when properly installed.
- Large molded diaphragm is extra sensitive to pressure changes.
- Built in pressure tap has plugged 1/8" F.NPT outlet. Plug can be removed with a 3/16" hex allen wrench.
- Select blue finish.

*Backmount Design

Mounts directly to house line piping. Eliminates need for union joints, elbows, and mounting brackets. Quick and easy to install.

Materials

Body (LV4403Y Series) Die Cast Zinc
 Body (LV5503Y Series) Die Cast Aluminum
 Bonnet (LV4403Y Series) Die Cast Zinc
 Bonnet (LV5503Y Series) Die Cast Aluminum
 Nozzle Orifice Brass
 Spring Steel
 Valve Seat Disc Resilient Rubber
 Diaphragm Integrated Fabric and Synthetic Rubber



LV4403Y Series



LV5503Y Series

LV4403Y4, LV4403Y46R

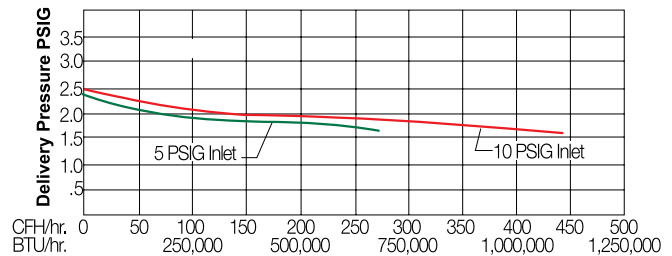

LV5503Y6

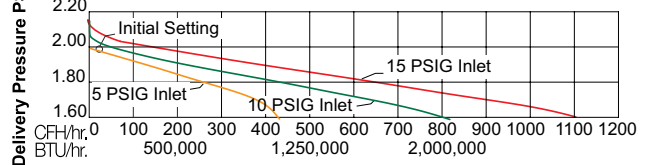

LV5503Y8

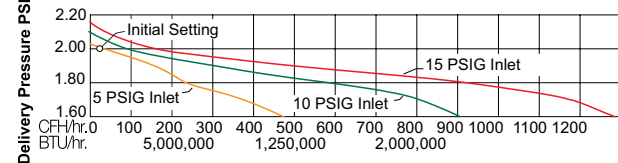

Ordering Information

Part Number	Inlet Connection	Outlet Connection	Orifice Size	Adjustment Range	Bonnet Vent Position	Vapor Capacity BTU/hr. Propane***
LV4403Y4	1/2" F. NPT	1/2" F. NPT	1/4"	2 PSIG @ 10 PSIG Inlet	Over Inlet	1,000,000
LV4403Y46R*	1/2" F. NPT	3/4" F. NPT	1/4"	2 PSIG @ 10 PSIG Inlet	Over Inlet	1,000,000
LV5503Y6	3/4" F. NPT	3/4" F. NPT	1/4"	2 PSIG @ 10 PSIG Inlet	Over Inlet	2,200,000
LV5503Y8	3/4" F. NPT	1" F. NPT	9/32"	2 PSIG @ 10 PSIG Inlet	Over Inlet	2,200,000

Maximum flow is based on 10 PSIG inlet pressure and 1.5 PSIG delivery pressure.

Low Pressure Second Stage Tobacco Barn Regulator LV5503G4 Series

Application

Especially developed for drying barns in the tobacco industry. The LV5503G4 regulator will supply a steady and constant flow of fuel to as many as 12 to 20 burners throughout the barn.



LV5503G4 Series

Features

- Similar to construction of the LV5503B Series. Provides the same stability, low lock-up, and sensitive performance.
- Equipped with integral relief valve.
- Built in pressure tap has plugged $\frac{1}{8}$ " F.NPT outlet. Plug can be removed with a $\frac{3}{16}$ " hex allen wrench.
- Distinctive yellow finish.

Materials

Body Die Cast Aluminum
 Bonnet Die Cast Aluminum
 Nozzle Orifice Brass
 Spring Steel
 Valve Seat Disc Resilient Rubber
 Diaphragm Integrated Fabric and Synthetic Rubber

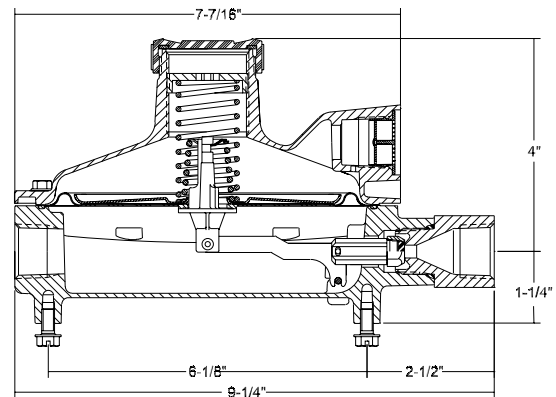
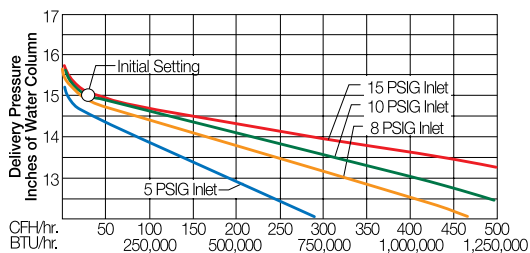

Ordering Information

Part Number	Inlet Connection	Outlet Connection	Orifice Size	Factory Delivery Pressure	Adjustment Range	Bonnet Vent Position	Vapor Capacity BTU/hr. Propane*
LV5503G4	$\frac{1}{2}$ " F. NPT	$\frac{3}{4}$ " F. NPT	$\frac{1}{4}$ "	15" w.c. at 15 PSIG Inlet	8" - 18" w.c.	Above Inlet	1,750,000

Maximum flow is based on 15 PSIG inlet pressure and 13" w.c. delivery pressure.

Compact Twin Stage Regulators LV404B4 and LV404B9 Series

Application

This compact two-stage regulator is designed to reduce container pressure down to 11" w.c. delivery pressure. It is ideal for "on-site" cylinder applications, mobile homes and average domestic service including small ASME and 100 to 420 pound DOT cylinders.

Features

- Incorporates integral relief valve.
- With 15 PSIG inlet pressure, regulator is designed to not pass more than 2 PSIG with the seat disc removed.
- Large vent helps prevent blockage and has 3/4" F. NPT for vent piping.
- Compact size allows for easy installation — especially under container hoods and within collars.
- Vent on the first stage is consistently in the down position.
- Built in pressure taps on both first and second stage regulators have plugged 1/8" F.NPT outlets. Plugs can be removed with a 3/16" hex allen wrench.
- Select brown finish.

Materials

Body (First Stage)..... Zinc or Brass
 Body (Second Stage) Die Cast Zinc
 Nozzle Orifice Brass
 Spring Steel
 Valve Seat Disc Resilient Rubber
 Diaphragm Integrated Fabric and Synthetic Rubber



LV404B4

LV404B4V9

LV404B9

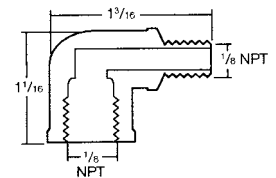

404PE Vent Pipe-away for first stage vent.

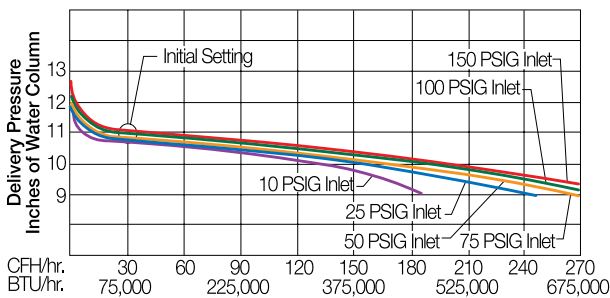
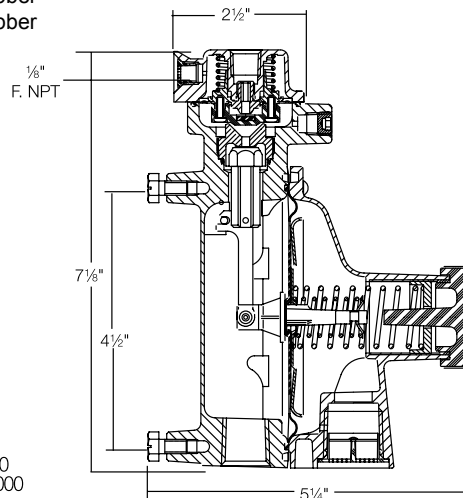

Ordering Information

Part Number	Inlet Connection	Outlet Connection	Orifice Size	Factory Delivery Pressure	Adjustment Range 2nd Stage	Bonnet Vent Position 1st Stage	Bonnet Vent Position 2nd Stage	Capacity BTU/hr. Propane*	Accessories
									1st Stage Vent Pipe-Away
LV404B4	1/4" F. NPT	1/2" F. NPT	3/16"	11" w.c. at 100 PSIG Inlet	9" - 13" w.c.	Down	Over Outlet	525,000	404PE
LV404B4V9						9 o'clock	9 o'clock		
LV404B46		3/4" F. NPT				Down	Over Outlet		
LV404B46V9						9 o'clock	9 o'clock		
LV404B9	F. POL	1/2" F. NPT				Down	Over Outlet		
LV404B9V9						9 o'clock	9 o'clock		
LV404B96		3/4" F. NPT				Down	Over Outlet		
LV404B96V9						9 o'clock	9 o'clock		

Maximum flow is based on 25 PSIG inlet pressure and 9" w.c. delivery pressure.

New Compact Twin Stage Regulators for LP-Gas LV404B34 & LV404B39 Series

Application

The compact twin-stage regulator is designed to reduce container pressure down to 11" w.c. delivery pressure. It is ideal for "on site" container applications such as homes, mobile homes and cottages for average domestic service; including small ASME tanks and 100-420 pound DOT cylinders.

Features

- Large vent helps prevent vent blockage, the second stage regulator bonnet is tapped for 3/8" F.NPT for vent piping, the high pressure regulator is tapped with 1/8" F.NPT for vent piping.
- With 15 PSIG inlet pressure, the regulator is designed to not pass more than 2 PSIG downstream with the seat disc removed.
- Incorporates an integral relief valve on second stage.
- Unique bonnet vent profile minimizes vent freeze over when properly installed.
- Compact design saves space allows for easy installation – especially under container hoods with collars.
- Built in pressure taps 1/8" F.NPT on both high pressure regulator inlet and downstream side of the second stage regulator.
- Plugs can be removed with a 3/16" hex Allen wrench.
- Select brown finish.

Materials

Body First Stage (LV404B39) Brass
 Body First Stage (LV404B34) Die Cast Zinc
 Bonnet Second Stage Die Cast Zinc
 Diaphragms Integrated Fabric and Synthetic Rubber
 Springs Steel and Stainless Steel
 Valve Discs Resilient Synthetic Rubber



LV404B39



LV404B34

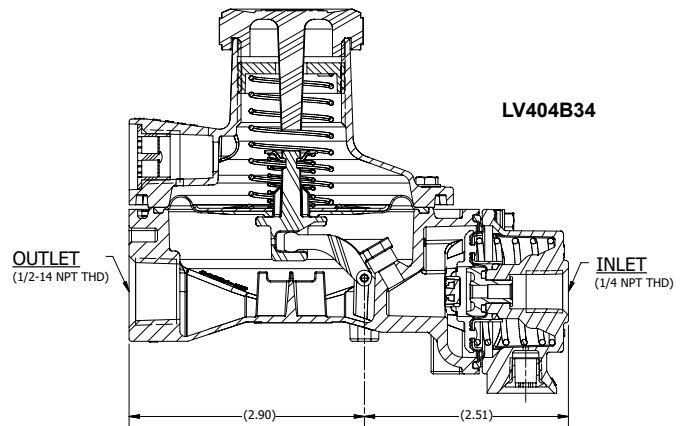

LV404B34

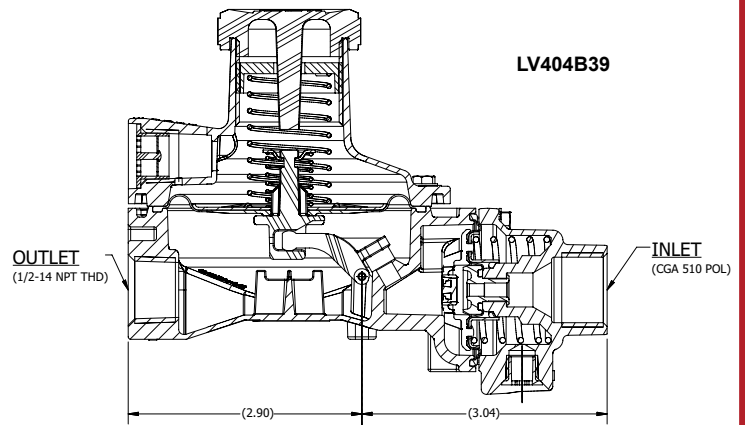

LV404B39

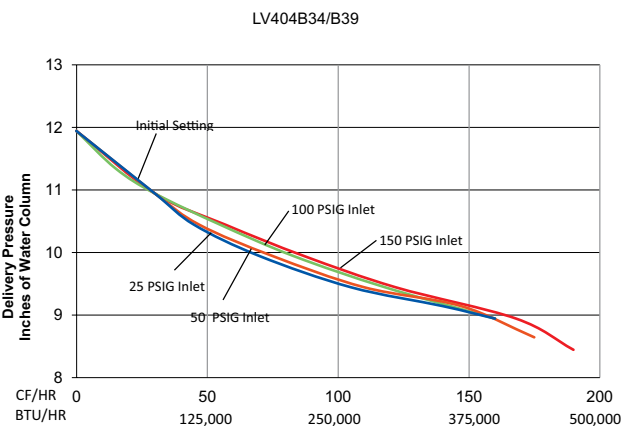

Ordering Information

Part Number	Inlet Connection	Outlet Connection	Orifice Size	Factory Delivery Pressure	Adjustment Range 2nd Stage	Bonnet Vent Position 1st stage **	Bonnet Vent Position 2nd stage**	Vapor Capacity BTU/hr *
LV404B34	1/4" F.NPT	1/2" F.NPT	7/32"	11" w.c. @ 100 Psig Inlet	9" to 13"w..c.	Rear	Outlet	450,000
LV404B39	F.POL							
LV404B34V9	1/4" F.NPT					Left	9:00	
LV404B39V9	F.POL							

* Maximum flow based on 10 PSIG Inlet 9" w.c. delivery pressure

** Other vent positions available upon request

Twin Stage Automatic Changeover Regulators

7525B Series

Application

These combination automatic changeover, two stage regulators are especially suitable for homes, mobile homes, cottages, construction and other portable two cylinder installations. Empty containers may be replaced without interrupting customer's gas service.

Features

- Automatic changeover switches from "service" to "reserve" cylinder automatically without interrupting service.
- The Second Stage Incorporates wide bonnet drip lip vent to guard against freeze-up when properly installed.
- With 15 PSIG inlet pressure the second stage, regulator is designed to not pass more than 2 PSIG with the seat disc removed.
- Allows "reserve" cylinder to supplement the flow of gas from the "service" cylinder during extreme load or severe cold conditions.
- Incorporates molded diaphragm in second stage regulators.
- Integral indicator gauge.
- Changeover knob and indicator are integral to the first stage.
- Select brown finish on first stage.



7525B34

7525B4

Materials

- Body (First Stage)..... Die Cast Zinc
- Body (Second Stage) Die Cast Zinc
- Bonnet First Stage Die Cast Zinc
- Bonnet, Second Stage Die Cast Zinc
- First Stage Nozzle Orifice Brass
- Springs Steel
- Valve Seat Discs Resilient Rubber
- Diaphragms Integrated Fabric and Synthetic Rubber

7525B34

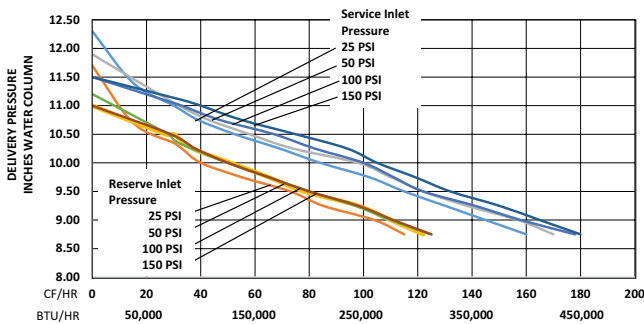

7525B4

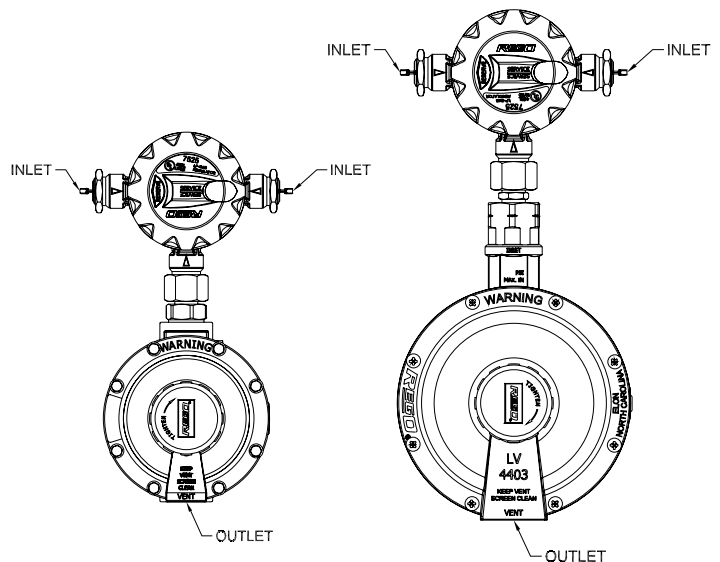
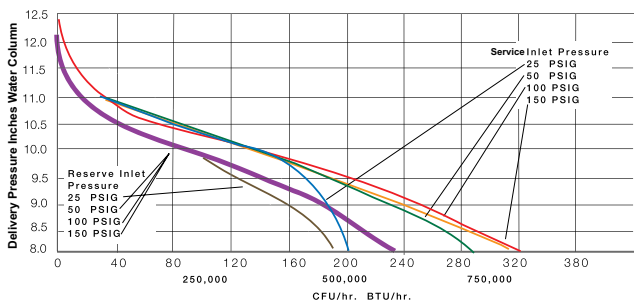

Ordering Information

Automatic Changeover Regulator	Inlet	Outlet	Pigtails	Bracket	Capacity BTU/hr. Propane
7525B34	¼" Inverted Flare	½" F. NPT	912FA20	2302-31	400,000
7525B34			912FS20		
7525B4			912FA20	2503-22	450,000
7525B4			912FS20		

Maximum flow is based on 25 PSIG inlet pressure and 9" w.c. delivery pressure.

Two PSIG Delivery Pressure Twin-Stage Regulators LV404Y9 & Compact LV404Y39

Application

SPECIAL 2 PSIG DELIVERY pressure twin stage regulator is designed to reduce container pressure down to 2 PSIG. A line pressure regulator is required downstream to reduce the 2 PSIG to a nominal 11" w.c.

Features

- Incorporates an integral relief valve in the 2 PSIG stage portion of the regulator.
- Designed to pass no more than 5 PSIG with the seat disc removed.
- Large vent helps prevent blockage and is tapped with a FNPT thread for piping away.
- Compact Design
- Built in pressure taps. Plugs can be removed with a 3/16" hex allen wrench.
- **Select Blue Finish** to designate 2 PSIG delivery pressure for 2-pound systems.

Materials

Body (First Stage)..... Brass
 Body (2 PSIG Stage) Die Cast Zinc
 Bonnet, Second Stage Die Cast Zinc
 Diaphragms Integrated Fabric and Synthetic Rubber
 Springs Steel and Stainless Steel
 Valve Discs Resilient Rubber



LV404Y39

LV404Y9

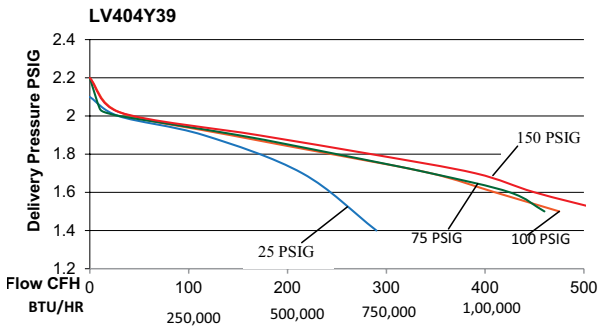
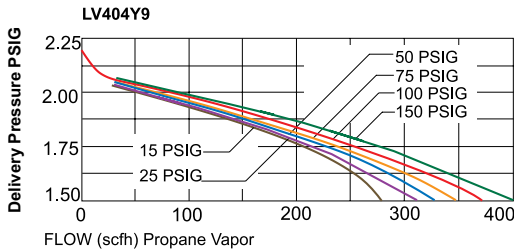
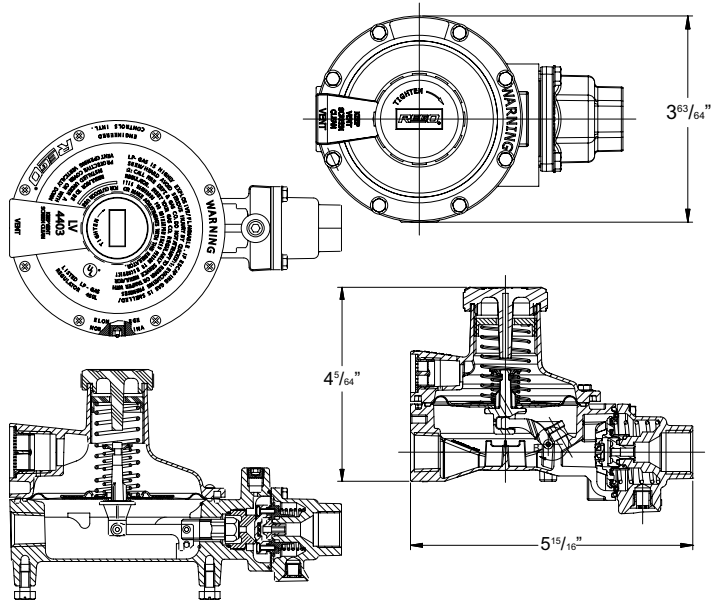

Ordering Information

Part Number	Inlet Connection	Outlet Connection	Orifice Size	Factory Delivery Pressure (PSIG)	Adjustment Range (PSIG)	Bonnet Vent Position 1st Stage	2 PSIG Bonnet Vent Position	Capacity BTU/HR*
LV404Y9	F.POL (CGA 510)	1/2" F.NPT	7/32"	2	1.8 to 2.5	Down	Outlet	800,000
LV404Y39								650,000

Maximum flow is based on 25 PSIG inlet pressure and 1.5 PSIG delivery pressure.

Two Stage Regulator Outfits

5807, 5808, 5820 Series

Application

These outfits contain the equipment required to provide two-stage regulation.

Features

- Includes a new pigtail. This helps ensure that a new pigtail is installed along with the regulator.
- Features, designs, and performance characteristics of the individual components may be found under the appropriate section of this catalog.

Ordering Information

Kit Number	1st Stage Regulator Included		2nd Stage Regulator Included		Bracket Included	Pigtail Included	Capacity BTU/hr. Propane
	Part Number	Inlet x Outlet Female	Part Number	Inlet x Outlet F. NPT			
5807	LV4403TR9	POL x 1/2" NPT	LV4403B4	1/2" x 1/2"	2503-22	913PS12	935,000
5808			LV4403B46R	1/2" x 3/4"			
5820	LV4403TR96	POL x 3/4" NPT	LV4403B66R	3/4" x 3/4"	Not Required		



LV4403TR9

LV4403B Series



913PS12



2503-22

Twin Stage Regulator Outfits 5828 and 5832

Application

This outfit contains the equipment required to provide twin-stage regulation.

Features

- Includes a new pigtail. This helps ensure that a new pigtail is installed along with the regulator.
- Features, designs, and performance characteristics of the individual components may be found under the appropriate section of this catalog.

Ordering Information

Kit Number	Twin Stage Regulator Included	Inlet F. NPT	Outlet F. NPT	Pigtails Included	Capacity BTU / hr. Propane
5828	LV404B4	1/4"	1/2"	912JS12	525,000
5832	LV404B34V9				450,000



LV404B4

LV404B34V9



912JS12



2503-22

Automatic Changeover Regulator Outfits 5726B34, 5727B34, 5754B4, 5755B4

Application

This outfit contains the equipment required to provide twin-stage regulation.

Features

- Includes 2 new pigtails. This helps ensure that a new pigtail is installed along with the regulator.
- Features, designs, and performance characteristics of the individual components may be found under the appropriate section of this catalog.

Ordering Information

Kit Number	Automatic Changeover Regulator Included	Inlet	Outlet	Pigtails Included-2	Bracket Included	Capacity BTU/hr. Propane
5726B34	7525B34	1/4" Inverted Flare	1/2" F. NPT	912FA20	2302-31	400,000
5727B34	7525B34			912FS20		
5754B4	7525B4			912FA20	2503-22	450,000
5755B4	7525B4			912FS20		



912FA20

7525B4

Compact Regulators 302 Series

Application

These compact regulators are designed for smaller outdoor grills and fish cookers. It is intended for use on small portable appliances that use 100,000 BTU's/hr. or less. It may not be used on fixed pipe systems per NFPA 58, 1995 edition.

Features

- All metal, die cast construction.
- Molded diaphragms ensure close control of burner pressure.
- Durable valve levers.
- Variety of model configurations and sizes available.
- All POL inlet connections are soft nose.

Materials

Body Die Cast Zinc
 Bonnet Die Cast Zinc
 Springs Steel
 Valve Seat Discs Resilient Rubber
 Diaphragms Molded Synthetic Rubber



302

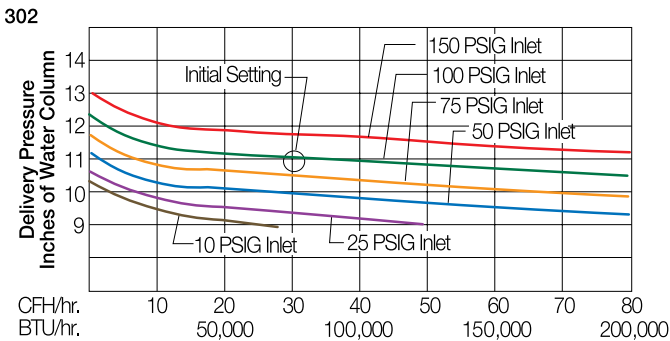
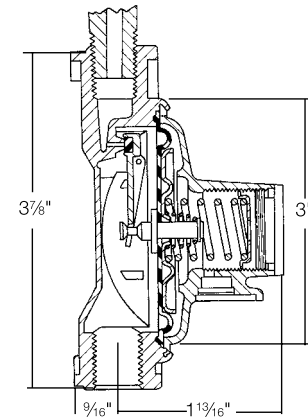

302V

Ordering Information

Part Number	Type	Inlet Connection	Outlet Connection	Orifice Size	Factory Delivery Pressure	Adjustment Range	Bonnet Vent Position	Vapor Capacity BTU/hr. Propane*
302	Single Stage	1/4" F. NPT	3/8" F. NPT	No. 50 Drill	11" w.c. at 100 PSIG inlet	9-13" w.c.	Small Vent Above Inlet	125,000
302V		1/4" F. NPT					Drip Lip Above Inlet	
302V9		1/4" F. NPT					Drip Lip at 9 o'clock	
302V9LS		Soft POL w/o orifice						

Maximum flow is based on 25 PSIG inlet pressure and 9" w.c. delivery pressure.

High Pressure Industrial / Commercial Pounds-to-Pounds Regulators

597F Series

Application

Designed to reduce propane gas container pressure down to between 3 and 100 PSIG. Ideal for liquid or vapor service, they can be used in a variety of applications including salamander heaters, weed burning torches, fish cookers, tar pot heaters, and other industrial type services.

Features

- Provides high capacity performance at a reasonable price.
- Suitable for both liquid and vapor service.
- Compact design provides for easy installation.
- Negative or indirect acting design provides for excellent performance when needed most – in cold weather, when tank pressures are lowest and system demands are highest.
- Consistent delivery pressure, especially in cold weather, helps ensure maximum performance from the second stage regulator.
- Can be readily fitted with a pressure gauge in the 1/4" F.NPT port.
- Molded diaphragm provides an o-ring like seal between the body and the bonnet.
- Fully painted in brilliant red for complete corrosion protection.
- Available in four adjustable ranges for maximum performance.
- Bonnet and body are assembled in the USA using the unique, patented RegULok™ Seal System.

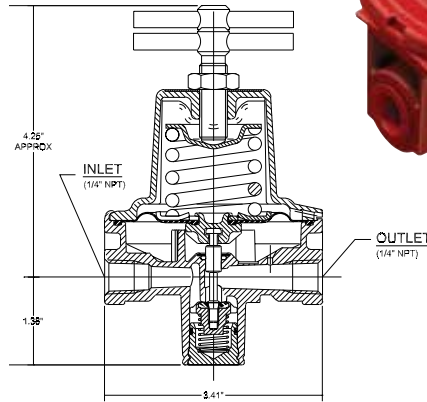

Materials

Body	Zinc
Bonnet	Zinc
Springs	Steel
Valve Seat Discs	Resilient Rubber
Diaphragms	Integrated Fabric and Synthetic Rubber
Adjusting Screw	Brass

597FA

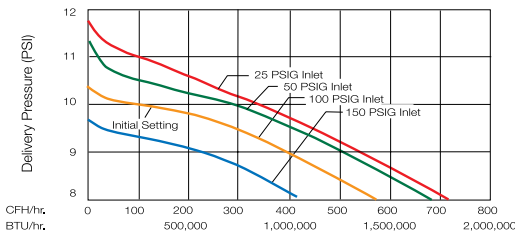

597FB

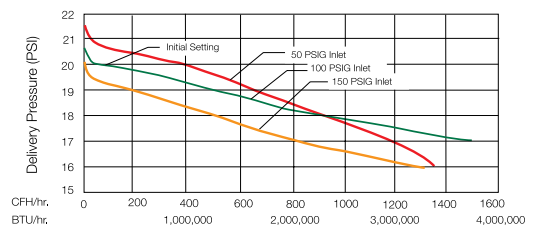

597FC

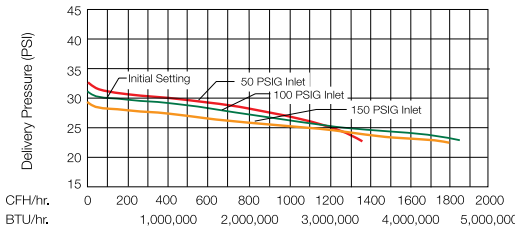

597FD

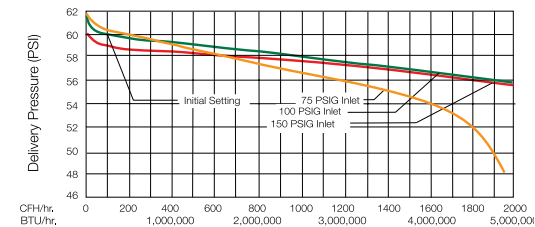

Ordering Information

Part Number	Adjustment Method	Inlet Connection	Outlet Connection	Recommended Delivery Pressure Range (PSIG)	Capacity Determined at Set Pressure of PSIG*	Capacity BTU/hr. Propane**
597FA	Tee Handle	1/4" NPT	1/4" NPT	1-15	10	1,750,000
597FB				10-30	20	3,000,000
597FC				20-45	30	3,500,000
597FD				40-100	40	4,500,000

* Set pressure established at 100 PSIG inlet and a flow of 250,000 BTU/hr.

** Capacity determined at actual delivery pressure 20% less than set pressure with inlet pressure 20 PSIG higher than the set pressure.

High Pressure Industrial / Commercial Pounds-to-Pounds Regulators 1580V and AA1580V Series

Application

Designed to reduce LP-Gas and anhydrous ammonia container pressures to between 3 and 125 PSIG. Precision-built with a multi-million BTU capacity, the 1580V series is perfect for such big, tough jobs as crop dryers, asphalt batch mixing plants, road building "tar wagons", heat treating and other large industrial and commercial loads. It's also ideal as a first stage regulator in large multiple operations. The AA1580V series is ideal for use in anhydrous ammonia applications such as blue print machines and heat treating.



Features

- Large nozzle and straight through flow provides high capacity and resistance to freeze-up.
- O-ring on retainer assembly provides a dampening effect to reduce vibration.
- Suitable for both liquid and vapor service.
- Can be readily fitted with pressure gauge in 1/4" F. NPT port.

Materials

Body Forged Aluminum
Bonnet Die Cast Aluminum
Spring Steel
Valve Seat Discs Resilient Rubber
Diaphragms Integrated Fabric and Synthetic Rubber



1580V

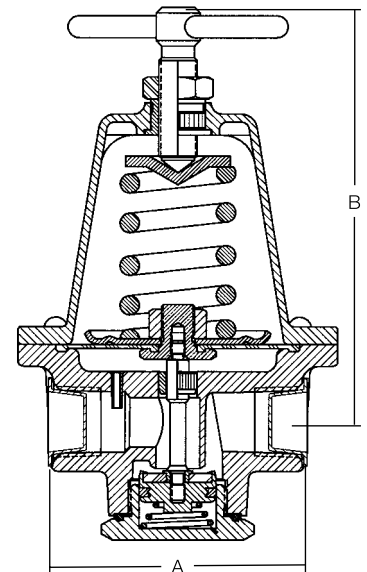

Ordering Information

Part Number	Service	Adjustment Method	Inlet & Outlet Connections	Recommended Delivery Pressure Range (PSIG)	A Width	B Height (max.)	Capacity Determined at Set Pressure of PSIG*	Capacity**	
1584VN	LP-Gas	Tee Handle	1/2" F. NPT	3-30	2 15/16"	4 7/8"	20	7,000,000 BTU/hr. LPG	
1584VL				25-50			30	10,000,000 BTU/hr. LPG	
1584VH				45-125			60	10,000,000 BTU/hr. LPG	
AA1584VW	NH3		3-25	3 1/2"	7"	20	4,500 CFH NH3		
AA1584VL			20-50			30	4,800 CFH NH3		
AA1584VH			45-125			60	5,100 CFH NH3		
1586VN	LP-Gas		Tee Handle	3/4" F. NPT	3-30	3 1/2"	7"	20	7,500,000 BTU/hr. LPG
1586VL					25-50			30	14,000,000 BTU/hr. LPG
1586VH					45-125			60	14,000,000 BTU/hr. LPG
AA1586VW	NH3	3-25		3 1/2"	7"	20	7,700 CFH NH3		
AA1586VL		20-50				30			
AA1586VH		45-125				60			
1588VN	LP-Gas	Tee Handle		1" F. NPT	3-30	3 1/2"	7"	20	7,500,000 BTU/hr. LPG
1588VL					25-50			30	14,000,000 BTU/hr. LPG
1588VH					45-125			60	14,000,000 BTU/hr. LPG

* Set pressure is established with 100 PSIG inlet pressure and a flow of 500,000 BTU/hr. propane for 1580V Series, and 180 CFH/hr. NH₃ for AA1584V and AA1586V Series.

** Capacity determined at 100 PSIG inlet, set pressure noted on chart at 20% drop.

NOTE: Care must be taken to prevent re-liquefaction of propane at normal temperatures by heat tracing or other effective means. Use of a relief valve upstream or downstream of these regulators is recommended in accordance with NFPA 58.

High Pressure Industrial / Commercial Pounds-to-Pounds Regulators

1580V, X1580V and AA1580V Series

1584/X1584 VN

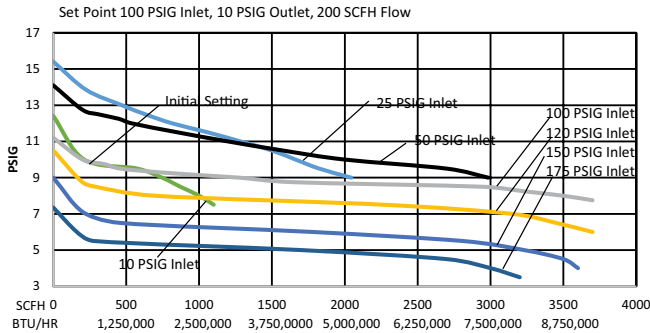

1586/X1586/1588 VN

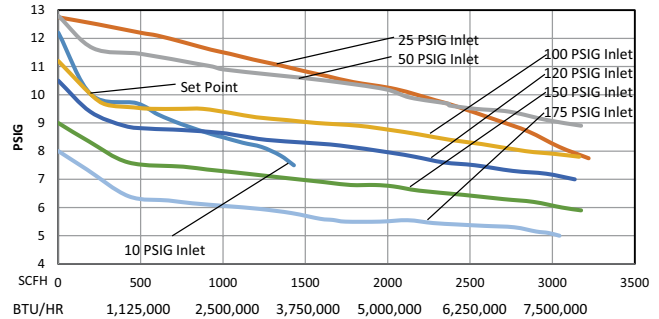

1584/X1584 VL

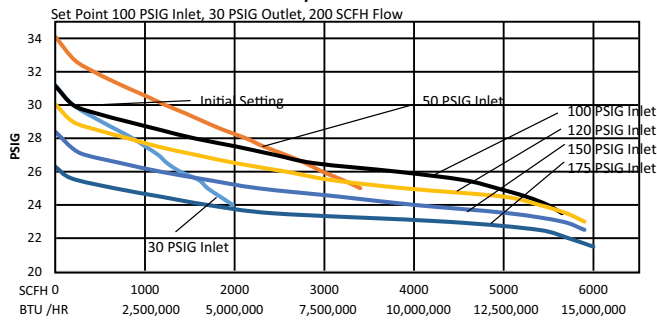

1586/X1586/1588 VL

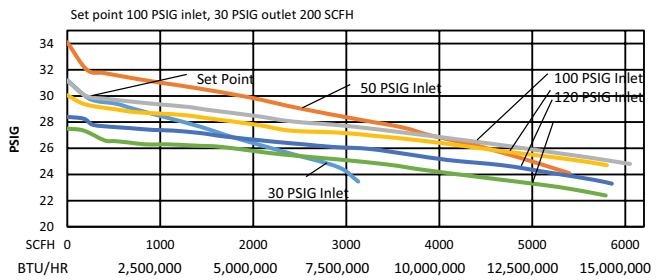

1584/X1584 VH

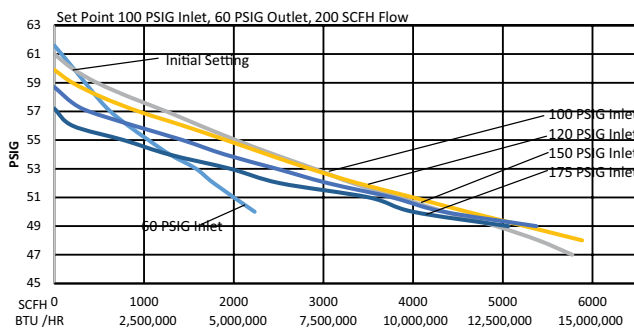

1586/X1586/1588 VH

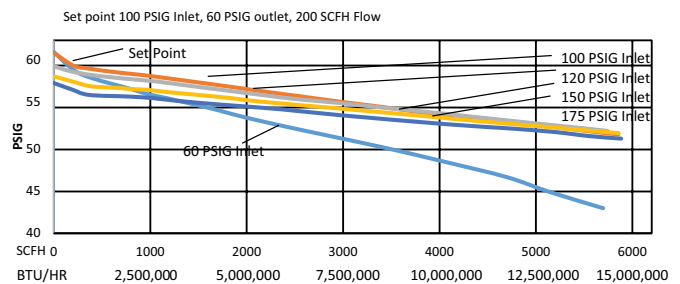

High Pressure / High Temperature Industrial / Commercial Pounds-to-Pounds Regulators X1584V, X1586V, and X1588V Series

Application

Designed to reduce LP-Gas container pressures to between 3 and 50 PSIG. Ideal for crop drying, heat treating, asphalt batch mixing and other large industrial and commercial load application utilizing high temperature LP-Gas or high temperature atmosphere under conditions up to 300°F. Also ideal as a first stage regulator in large multiple operations.

Features

- Special diaphragm and seat materials are suitable for up to 300°F. temperatures.
- Large nozzle and straight through flow provides high capacity and resistance to freeze ups.
- Suitable for both liquid and vapor service.
- Can be fitted with high pressure gauge in 1/4" F. NPT port. RegO recommends that these gauges use silver braze rather than soft solder construction.

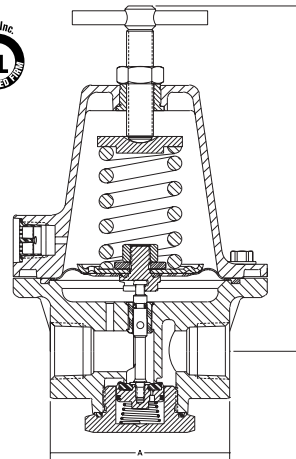

X1584

Materials

Body Forged Aluminum
 Bonnet Die Cast Aluminum
 Spring Stainless Steel
 Diaphragms Integrated Fabric and Synthetic Rubber
 Seat Discs High Temperature Resilient Composition
 Backup Seal High Temperature Resilient Composition



Ordering Information

Part Number	Service	Adjustment Method	A	B	Inlet & Outlet Connections	Recommended Delivery Pressure Range (PSIG)	Capacity Determined at Set Pressure of PSIG*	Capacity BTU/hr. Propane**
X1584VN	LP-Gas	Tee Handle	2 7/8"	8 7/8"	1/2" F. NPT	3-30	20	7,000,000
X1584VL						25-50	30	10,000,000
X1586VN			3 5/16"	6 7/8"	3/4" F. NPT	3-30	20	7,500,000
X1586VL						25-50	30	14,000,000
X1588VN					1" F. NPT	3-30	20	7,500,000
X1588VL						25-50	30	14,000,000

* Set pressure is established with 100 PSIG inlet pressure and a flow of 500,000 BTU/hr. propane.

** Capacity determined at 100 PSIG inlet, set pressure noted on chart at 20% drop.

NOTE: Care must be taken to prevent re-liquefaction of propane at normal temperatures by heat tracing or other effective means. Use of a relief valve upstream or downstream of these regulators is recommended in accordance with NFPA 58.

A

Vapor Relief Valves 3139 Series

Application

Designed for use as a relief valve on high pressure regulators to comply with NFPA 58 5.1.1 "High-pressure regulators with a rated capacity of more than 500,000 BTU/hr where permitted to be used on two stage systems shall incorporate an integral relief valve or shall have a separate relief valve."

Features

- Pop-action design keeps product loss to a minimum.
- Suitable for use downstream of 1580 series regulators on vapor systems to comply with NFPA 58 requirements.
- Install a tee downstream from the regulator outlet to ensure maximum flow from the relief valve.
- Brass body and seat disc assembly.



3139-18

3139-26

3139-38



Part Number	Set Pressure	Regulator Settings	Connection Size	Height	Width	Flow Capacity at 120% of Set Pressure (SCFH Propane)	Pipe Away Adapter
3139-18	18 PSIG	10 PSIG	1/4" M. NPT	2 27/32"	1 1/16"	1357*	B-009412-2B
3139-26	26 PSIG	15 PSIG				1725**	
3139-38	38 PSIG	20 PSIG				2304***	

* Flow recorded at 21.6 PSI inlet pressure for this valve. ** Flow recorded at 31.2 PSI inlet pressure for this valve. *** Flow recorded at 45.6 PSI inlet pressure for this valve.

Copper Pigtails 912 and 913 Series

Application

Pigtails are available in a variety of connections, sizes and styles. Care should always be taken in selecting the proper pigtail for a particular application.

Note: RegO recommends a new pigtail be installed with every new and replaced regulator.

Features

- Heavy duty construction.
- Individually soldered connections to the copper tubing.
- Each pigtail is individually tested prior to shipment.

Materials

Tubing..... Copper
Connection Brass



913PS12

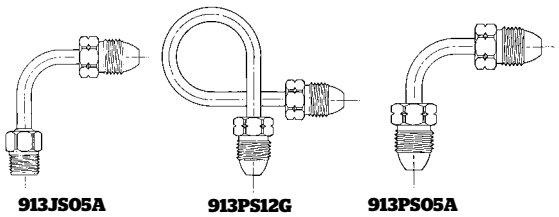

913JS05A

913PS12G

913PS05A

Bent Pigtails Ordering Information

Connections	Approximate Length	Part Number		Type/Degree of Bend
		3/8" Tube	1/2" Hex Short Nipple	
1/4" M. NPT x M. POL	5"	913JS05A		90°
		913PS05A		
M. POL x M. POL	12"	913PS12G		270° Right Hand
		913PS12H		270° Left Hand
		913PS12S		360°

Straight Pigtails Ordering Information

Connections	Approximate Length	Part Number		
		1/4" Tube		3/8" Tube
		3/8" Hex Short Nipple	1/8" Hex Long Nipple	3/8" Hex Short Nipple
M.POL x M.POL	5"	-	1/2"	913JS05
	12"	912PS12	-	913PS12
	20"	912PS20	912PA20	913PS20
	30"	912PS30	-	913PS30
	36"	912PS36	912PA36	913PS36
1/4" Inverted Flare x M.POL	48"	912PS48	912PA48	913PS48
	12"	912FS12	-	-
	20"	912FS20	912FA20	-
	30"	912FS30	-	-
1/4" M.NPT x M.POL	36"	912FS36	-	-
	5"	-	-	913JS05
	12"	912JS12	-	-
	20"	912JS20	-	-
1/2" M.NPT x M.POL	36"	912JS36	-	-
	12"	-	-	913LS12
1/2" M.NPT x 3/8" M.NPT	12"	-	-	913KL12

Dielectric Pigtails



D912

Part Number	Approximate Length	Tube	Connections
D912P12	12"	1/4"	M.POL x M.POL
D912P20	20"		
D912P30	30"		
D912J12	12"		
D912J20	20"	3/8"	1/4" M.NPT x M.POL
D912J30	30"		
D913P12	12"		
D913P20	20"	3/8"	M.POL x M.POL
D913P30	30"		
D913J12	12"		
D913J20	20"		
D913J30	30"		1/4" M.NPT x M.POL

Inlet Fittings

Part Number	Description
970	Hard nose POL with wrench nut.
970AX	Hard nose POL with wrench nut and excess flow.
970AXS	Soft nose POL with wrench nut and excess flow.
970WXS	
3199W	Heavy duty hard nose POL with wrench nut and excess flow.
970AW	Soft nose POL with Handwheel.
970HT	Soft nose POL with Handwheel and 60 DMS orifice.
970S	Soft nose POL with wrench nut and 60 DMS orifice.

These inlet fittings are available for assembly into either first stage of single stage regulators. All have 1/4" M. NPT connections and are machined from brass.



3199W



970

970AX

970AXS

970AW

970HT

970S

Brackets

RegO Brackets are especially designed for use in installing RegO Regulators in applications requiring the use of a bracket.

Part Number	Material	For Use With Regulator Model:
2302-31	Cadmium Plated Steel	LV3403, LV404B34, LV404B39
2503-22		LV404B4 LV404B9 Series, LV5503 Series
2503-19	Aluminum	LV4403 Series



2503-19



2503-22



2302-31

Manifolds

Tee Check Manifolds

1350R and 1450R

Application

For use in systems that require uninterrupted gas service during cylinder exchange. Especially for summer cottages, mobile homes and single appliance loads.

- Floating disc check minimizes discharge of gas to the atmosphere when empty cylinder is being replaced.

Features

- Floating disc check minimizes discharge of gas to the atmosphere when empty cylinder is being replaced.

Materials

Body Forged Brass
 Seat Discs Resilient Rubber

Part Number	Inlet Connections	Outlet Connection
1350R	F. POL	M. POL
1450R	1/4" Inverted Flare	1/4" M. NPT



1350R

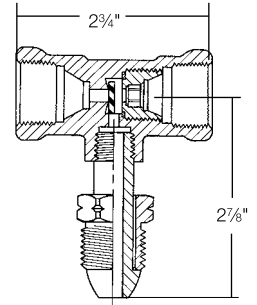

1450R

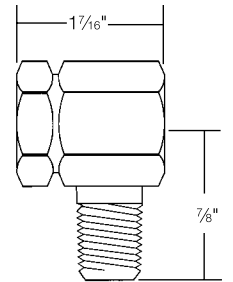

Multiple Cylinder Manifolds

1350E and 1450E

Application

Use with suitable pigtails to connect multiple cylinders together. Ideal for loads that require more than one cylinder to be in service at a time.

Features

- Provides a three-way tee function without an internal disc check.

Materials

Body Forged Brass

Part Number	Inlet Connections	Outlet Connection
1350E	F. POL	M. POL
1450E	1/4" Inverted Flare	1/4" M. NPT



1350E

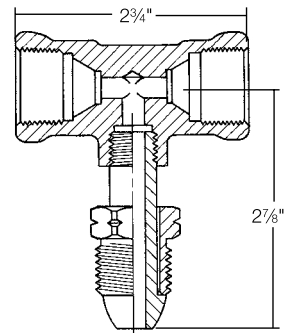

1450E

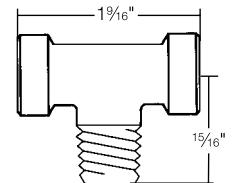

Adjustable Flexible Vent Kit

Part Number	Flex Tubing Length	Reusable End Connectors	90° Elbow	Mounting Bracket
LV960-48	48" (4 feet)	2	1	3
LV960-72	72" (6 feet)			4
LV960-120	120" (10 feet)			5

REGO
10
YEAR
WARRANTY



LV960

Test Kits

Low Pressure Test Set

2434A Series

This kit provides the equipment necessary for checking regulator delivery pressure (low pressure) at the appliances. The basic set contains a 2424A-2 low pressure gauge and a 3 foot — 3/16" O.D. flexible synthetic rubber tube. Adapters are also available.

Part Number	Contents	Adapters	Adapter size
2434A	Test Kit	1328	3/8" OD
		1331	1/2" OD
		1332	5/8" OD



2434A



1328 Adapter

REGO
10
YEAR
WARRANTY

Water Manometer Kit

1212 Kit

Application

The water manometer kit is especially suited for use with low pressure LP-Gas systems. It is ideal for pressure checks downstream of the low pressure regulator and at the appliances.

Features

- Flexible tube rolls up for convenient storage with accessories in compact carry case.
- Magnetic clips allow easy attachment to metal surfaces.
- Flexible spring steel scale is calibrated in inches of water column for reading to 16" w.c.
- Molded nylon tubing connectors incorporate a rapid shut-off design in an unbreakable molded top.
- Rapid pressure safety trap prevents loss of fluid due to pressure surges on both columns.
- Scale is center mounted between columns to eliminate parallax error and has a full two-inch sliding zero adjustment.

Contents

- 1—Flexible water manometer which reads up to 16" w.c. of pressure.
- 1—Heavy duty, compact carrying case.
- 1—3/4 oz. bottle of Fluorescein Green color concentrate.
- 2—1/8" pipe thread barbed tubing adapters.
- 1—3 foot, 3/16" rubber tube.
- 1—Rubber tubing adapter and 7/16" spud.



1212 KIT

REGO
10
YEAR
WARRANTY

Part Number	Description
1212 KIT	Flexible Tube Water Manometer Kit

Accessories

High Pressure Gauge Adapter

2962

Designed for testing high pressure lines. Adapter has 0 to 300 PSIG gauge. A bleeder valve allows you to bleed down to correct pressure during pressure tests.

Part Number	Inlet Connection	Outlet Connection	Pressure Gauge Range (PSIG)
2962	Soft Nose M. POL	F. POL	0 - 300



2962

Adhesive Warning Labels

These adhesive warning labels are intended for application as close as possible to the LP-Gas regulator once the regulator has been installed.

Part Number	Description
LV4403-400	Adhesive Warning Label

DANGER WARNING

**LP-GAS IS EXTREMELY
FLAMMABLE AND EXPLOSIVE**

AVOID SERIOUS INJURY AND PROPERTY DAMAGE. IF YOU SEE, SMELL, OR HEAR ESCAPING GAS... EVACUATE AREA IMMEDIATELY! CALL YOUR LOCAL FIRE DEPARTMENT! DO NOT ATTEMPT TO REPAIR. DO NOT STORE IN BUILDING OR ENCLOSED AREA. DO NOT USE ON HOT AIR BALLOONS OR AIRCRAFT.

Insist that your LP-Gas dealer regularly inspect and maintain this installation and properly instruct you in safety matters.

Make sure ice, snow drifts, dirt, bugs and other foreign material do not obstruct vent passage-ways and openings. The vent opening must have a screen installed. If screen is missing, call your gas dealer for immediate examination and replacement.

**DO NOT REMOVE, DEFACE OR OBLITERATE THIS LABEL.
DO NOT FILL CONTAINER UNLESS THIS LABEL IS READABLE.**

ADDITIONAL SAFETY INFORMATION IS AVAILABLE FROM

REGO

Printed in U.S.A. 04-0994-1189
Part Number LV4403-400
100 RegO Drive PO Box 247 Elon College, NC 27244 USA Phone (336) 449-7707 Fax (336) 449-6594 www.regoproducts.com

LV4403-400

DANGER READ THIS FIRST WARNING

LP-GAS IS EXTREMELY FLAMMABLE AND EXPLOSIVE

AVOID SERIOUS INJURY AND PROPERTY DAMAGE. IF YOU SEE, SMELL OR HEAR ESCAPING GAS...EVACUATE AREA IMMEDIATELY! CALL YOUR LOCAL FIRE DEPARTMENT! DO NOT ATTEMPT TO REPAIR. DO NOT STORE IN BUILDING OR ENCLOSED AREA. DO NOT USE ON HOT AIR BALLOONS OR AIRCRAFT.

Make sure you are thoroughly trained before you attempt any regulator installation or maintenance. Improper conditions or procedures can cause accidents resulting in property damage and personal injury.

Become thoroughly familiar with NPGA Safety Pamphlet 306 "LP-Gas Regulator and Valve Inspections & Maintenance" and RegO Safety Warning "LP-Gas Regulators" found in the regulator section of the L-500 & L-102 Catalogs. Follow its recommendations.

Know and understand NFPA Pamphlet 58 "Liquefied Petroleum Gas Code", which is the law in many states. This publication is available from NFPA, Batterymarch Park, Quincy, MA 02269. Following its requirements is essential in the safe use of LP-Gas. Section 4.4 states: "Persons who transfer liquid LP-Gas, who are employed to transport LP-Gas, or whose primary duties fall within the scope of this code shall be trained in proper handling procedures. Refresher training shall be provided at least every three years and shall be documented."

Pamphlet 58 also states that "All regulators for outdoor installations, except regulators used for portable industrial applications, shall be designed, installed or protected so their operation will not be affected by the elements (freezing rain, sleet, snow, ice, mud or debris). This protection may be integral with the regulator."

Vents must be clear and fully open at all times. An obstructed vent will prevent the regulator from functioning properly and may result in property damage and personal injury.

Regulators should be installed with the vent facing down or otherwise covered for protection.

Twin-Stage Regulators should be installed completely under cover and/or with screened vent pipe away adapters that position both vents in a down position without obstructing flow through the vents.

Make sure piping is clean and free from foreign material (such as dirt, corrosion, chips, pipe joint compound, etc.) Always replace the pigtail when replacing a regulator. Thread sealant used on piping must be compatible with LP-Gas.

Make sure the use and location of the regulator(s) as a component(s) of the LP-Gas system to be installed is proper. (Avoid misusing LP-Gas equipment.) See the following RegO publications: L-500 & L-102 Catalogs and the LP-Gas Serviceman's manual.

For underground installations, make sure that water, mud, dirt, and insects cannot get into the regulator, and that the regulator is easily accessible for regulator maintenance. Follow NPGA Bulletin 401. See RegO Safety Warning "LP-Gas Regulators" found in the regulator section of the L-500 & L-102 Catalogs.

Check regulator and installation for leaks following NFPA #54 and NPGA Bulletin 403 "Pressure Testing and Leak Checking LP-Gas Piping Systems".

In selecting a label for posting at the installation site, consider RegO part number 2403-400 along with your own, NPGA's and others.

Remember to instruct the owner/user/customer in safety matters concerning LP-Gas and this equipment. See RegO Safety Warning "LP-Gas Regulators" found in the regulator section of the L-500 & L-102 Catalogs.

RegO requests that this information be forwarded to your customers. Additional copies are available from RegO and your authorized RegO Distributor.

REGO

Printed in USA 08A-0910-0390
Part number LV4403-500
Elon, N.C. 27244 U.S.A. Phone (336) 449-7707 Fax (336) 449-6594 www.regoproducts.com

LV4403-500

Warning Notice

The following warning information, Part Number LV4403-500, is included with each shipment of regulators to the first purchaser of the product from the factory.

This information is intended to be forwarded throughout the product distribution chain. Additional copies are available from RegO and Authorized Product Distributors.

A