

Section B
Cylinder and Service Valves

B

Limited 10 Year Warranty and Limitation Of Liability

LIMITED 10 YEAR WARRANTY

RegO warrants to the original purchasers the products and repair kits manufactured by it to be free from defects in materials and workmanship under normal use and service for a period of 10 years from the date of manufacture. If within thirty days after buyer's discovery of what buyer believes is a defect, buyer notifies in writing and ships the product to RegO at 100 RegO Drive, Elon, NC 27244, RegO, at its option, and within forty-five days of receipt, will repair, replace F.O.B. point of manufacture, or refund the purchase price of that part or product found by RegO to be defective. Failure of buyer to give such written notice and ship the product within thirty days shall be deemed an absolute and unconditional waiver of any and all claims of buyer arising out of such defect.

This warranty does not extend to any product or part that is not installed and used after installation in accordance with RegO's printed instructions, all applicable state and local regulations, and all applicable national standards, such as those promulgated by NFPA, DOT and ANSI. This warranty does not extend to any product or part that has been damaged by accident, misuse, abuse, failure to maintain, or neglect, nor does it extend to any product or part which has been modified, altered, disassembled, or repaired in the field. This warranty does not cover any cosmetic issues, such as scratches, dents, marring, fading of colors or discoloration.

Except as expressly set forth above, and subject to the limitation of liability below, RegO MAKES NO OTHER WARRANTY, EXPRESS OR IMPLIED, INCLUDING, BUT NOT LIMITED TO, THE IMPLIED WARRANTIES OF MERCHANTABILITY AND FITNESS FOR A PARTICULAR PURPOSE, with respect to its products and parts, whether used alone or in combination with others. RegO disclaims all warranties not stated herein.

LIMITATION OF LIABILITY

RegO's total liability for any and all losses and damages arising out of any cause whatsoever shall in no event exceed the purchase price of the products or parts in respect of which such cause arises, whether such cause be based on theories of contract, negligence, strict liability, tort or otherwise.

RegO shall not be liable for incidental, consequential or punitive damages or other losses. RegO shall not be liable for, and buyer assumes any liability for, all personal injury and property damage connected with the handling, transportation, possession, further manufacture, other use or resale of products, whether used alone or in combination with any other products or materials.

From time to time buyers might call to ask RegO for technical advice based upon limited facts disclosed to RegO. If RegO furnishes technical advice to buyer, whether or not at buyer's request, with respect to application, further manufacture or other use of the products and parts, RegO shall not be liable for such technical advice or any such advice provided to buyer by any third party and buyer assumes all risks of such advice and the results thereof.

NOTE: Some states do not allow the exclusion or limitation of incidental, consequential or punitive damages, so the above limitation or exclusion may not apply to you. The warranty gives you specific legal rights, and you may have other rights that vary from State to State. The portions of this limited warranty and limitation of liability shall be considered severable and all portions which are not disallowed by applicable law shall remain in full force and effect.

WARNING

All RegO products are mechanical devices that will eventually become inoperative due to wear, corrosion and aging of components made of material such as rubber, etc. The environment and conditions of use will determine the safe service life of these products. Periodic inspection and maintenance are essential to avoid serious injury and property damage.

Many RegO products are manufactured components which are incorporated by others on or in other products or systems used for storage, transport, transfer and otherwise for use of toxic, flammable and dangerous liquids and gases. Such substances must be handled by experienced and trained personnel only, using accepted governmental and industrial safety procedures.

NOTICE TO USERS OF PRODUCTS

The Limited Warranty stated above is a factory warranty to the first purchasers of RegO products. Since most users have purchased these products from RegO distributors, the user must within thirty (30) days after the user's discovery of what user believes is a defect, notify in writing and return the product to the distributor from whom he purchased the product/part. The distributor may or may not at the distributor's option choose to submit the product/parts to RegO, pursuant to this Limited Warranty. Failure by buyer to give such written notice within thirty (30) days shall be deemed an absolute and unconditional waiver of buyer's claim for such defects. Acceptance of any alleged defective product/parts by RegO's distributor for replacement or repairs under the terms of RegO's Limited Warranty in no way determines RegO's obligations under this Limited Warranty.

Because of a policy of continuous product improvement, RegO reserves the right to change designs, materials or specifications without notice.

Foreword

This catalog describes a complete line of equipment available from RegO® for use with Liquid Propane (LP)-Gas and anhydrous ammonia (NH₃). The following points are important to know for proper use of the catalog:

1. Illustrations and drawings of individual products are representative of “product groups” and all products within a product group are similar in construction.
2. Materials used for construction of products in this catalog are suitable for rated service pressure at temperatures of -40°F to +165°F, unless otherwise specified.
3. Products in this catalog are only intended for use in LP-Gas and/or anhydrous ammonia service as follows.
 - a. “A” or “AA” prefix — Products with this prefix are suitable for NH₃ service (i.e., contain no brass parts).
 - b. “AA” prefix on relief valves — These valves are NOT suitable for use with LP-Gas service. These are of partial aluminum materials and are listed by Underwriters Laboratories (UL) for NH₃ service only.
 - c. All other products including “A” prefix are suitable for use with LP-Gas & NH₃ service.
 - d. “SS” prefix—Hydrostatic relief valve with this prefix are suitable for NH₃ and LP-Gas service (i.e., they have stainless steel materials).
4. We manufacture valves and adapters designed to be used on LP-Gas and Anhydrous Ammonia systems, we do not design systems or consult in system design. For this type of information consult a professional Engineer.

Caution

Do not use any product contained in this catalog with any service commodity other than LP-Gas or NH₃. If you have a need for use of another application, contact RegO, 100 RegO Drive, Elon, NC 27244, (336) 449-7707 ecii@regoproducts.com before proceeding.

Proper application, installation and maintenance of products in this catalog are essential. Users of these products should obtain further information if there are any doubts or questions.

Warning

All RegO products are mechanical devices that will eventually become inoperative due to wear, corrosion and aging of components made of materials such as rubber. The environment and conditions of use will determine the safe service life of these products. Periodic inspection and maintenance are essential to avoid serious injury and property damage.

Many RegO products are manufactured for storage, transport, transfer and use of toxic flammable and dangerous liquids and gases. Such substances should be handled by experienced and trained personnel only, using accepted governmental and industrial safety procedures. Never vent LP-Gas near any possible source of ignition.

Notice

Installation, usage, and maintenance of all RegO products must be in compliance with all RegO instructions as well as requirements and provisions of NFPA #54, NFPA#58, DOT, ANSI, and all applicable federal, state, provincial and local standards, codes, regulations, and laws.

Inspection and maintenance on a periodic basis is essential. Installation and maintenance should be performed only by qualified personnel.

Be sure all instructions are read and understood before installation, operation and service.

Filters

RegO LP-Gas equipment is designed to operate in a system free from contamination. A variety of in-line filters are commercially available to the LP-Gas industry for installation in domestic systems.

The use of an in-line filter should be considered when other system components may be unclean and the system contaminated by rust, scale, dirt, debris or other foreign material.

LP-Gas Cylinder and Service Valves

Safety Warnings



Purpose

In its continuing quest for safety, RegO publishes a series of bulletins explaining the hazards associated with the use, misuse, and aging of LP-Gas valves and regulators. It is hoped that these factual bulletins will make clear to LP-Gas dealer managers and service personnel, that the utmost care and attention must be used in the installation, inspection, and maintenance of these products, or problems could occur which would result in injuries and property damage.

The National Fire Protection Association NFPA 58 Liquefied Petroleum Gas Code - 2017 Edition states in Section 4.4 Qualification of Personnel; "Persons whose duties fall within the scope of this code shall be provided with training that is consistent with the scope of their job activities and that includes proper handling and emergency response procedures... Refresher training shall be provided at least every 3 years, initial and subsequent training shall be documented". These "RegO Safety Warnings" may be useful in training new employees and reminding older employees of hazards that can occur. It is recommended that all employees complete the Propane Education Research Council's Certified Employee Training Program.

Nature of Warnings

It is recognized that warnings should be as brief as possible, but the factors involved in cylinder valve failure are many because of the multiple functions the valve serves. If there is any simple warning, it would be:

Check cylinder valves for leaking components every time cylinders are filled.

The bulletin is not intended to be an exhaustive treatment of the subject of cylinder valves and certainly does not cover all safety practices that should be followed in installation, operation and maintenance of LP-Gas systems which include cylinder valves.

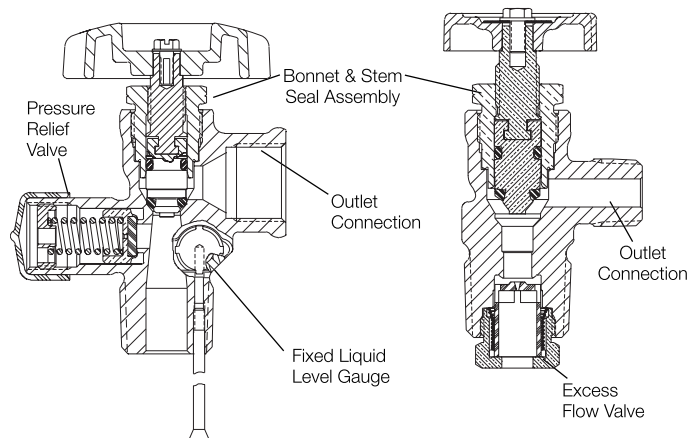

LP-Gas Cylinder Valves

These valves are mounted in DOT cylinders, and are intended to provide one or more of the following functions:

1. Vapor service shut-off
2. Liquid service shut-off (with excess flow valve)
3. Liquid filling
4. Pressure relief
5. Fixed liquid level gauge

These functions, although simple, are extremely critical in the safe operation of an LP-Gas cylinder system.

Abuse of these valves, failure to follow a good installation and maintenance program and attempting to use cylinder valves beyond their normal service life can result in extremely hazardous conditions.

Important Factors:

1. Installation: It should not be necessary to remind the readers that cylinder valves must be installed and used in strict conformance with NFPA Pamphlet 58, and all other applicable codes and regulations. Codes, regulations and manufacturers' recommendations have been developed by experts with many years of experience in the LP-Gas industry in the interest of safety for users of LP-Gas and all personnel servicing LP-Gas systems. Failure to fully follow these codes, regulations and recommendations could result in hazardous installations.

2. The bonnet and stem seal assembly of a cylinder valve are extremely critical, since any malfunction could cause external leakage and spillage. Check bonnet to see that it is in proper position. If there is any doubt about tightness of threaded connection between bonnet and body, valve must be repaired in accordance with manufacturers' repair instructions before cylinder is filled. Handwheel must be in good condition, stem threads must not be worn or damaged and bonnet must be properly assembled. This area should be examined each time the cylinder is filled. A leakage test should be conducted while the shut-off valve is in the open position during filling.

3. The cylinder outlet connection is usually a female POL. Threads must be free of dents, gouges and any indication of excessive wear. Seating surface inside this connection must be smooth and free of nicks and scratches to ensure a gas tight seal when connected to a male POL cylinder adapter. Cylinder adapter must spin on freely all the way, without indication of drag, roughness or excessive looseness, and must then be tightened with a wrench. Connection must be checked for leakage.

4. The pressure relief valve is of critical importance: Its proper operation is vital in avoiding excessive pressures during emergencies, such as overfilling or exposure to excessive heat. No repair of this device is allowable. Relief valve should be visually inspected and checked for leaks each time the cylinder is returned for filling. All flow passages must be clean and free of foreign material.

LP-Gas Cylinder and Service Valves

Entire assembly must be free of dents, distortion or other indications of damage. If relief valve appears too contaminated or damaged, the cylinder valve must be replaced. (Caution: Eye protection must be used when examining relief valves under pressure.)

5. The liquid service shut-off valve, with excess flow valve provided on some cylinder valves, is also of critical importance. The excess flow valve must be periodically tested for proper performance, in addition to the inspection of the shut-off valve.

6. The fixed liquid level gauge on a cylinder valve is, when present, essential to prevent overfilling the cylinder. The gauging valve must operate freely, venting vapor when loosened, and sealing gas-tight easily when tightened with the fingers. Gauge valves meant for use with a socket key or screwdriver must also seal easily without excessive torque. The fixed liquid level gauge diptube must be of the proper length, and be in proper position. Periodic test should be conducted by weighing the cylinder after filling, to determine that it does not contain more than the allowable amount of LP-Gas. This check should be done periodically, and any time there is suspicion that the gauge diptube may be damaged or broken.

Do Not Overfill Cylinders

Do not fill a cylinder without first repairing or replacing the cylinder valve, as required, if any defect is noted.

While not required by codes, it is recommended that a plug or suitable protection be inserted in the POL outlet of the cylinder valve at all times except during filling and while connected for use. This will guard against discharge of gas should the handwheel be inadvertently opened while the cylinder is in storage or transit. This is highly advisable for small cylinders that could be transported inside an automobile or trunk. It is important that proper wrenches and adapters be used when filling, servicing and installing cylinder valves in order to avoid damage to the valve or associated piping.

Since cylinders are often used by consumers without previous knowledge of the hazards of LP-Gases and the LP-Gas dealers are the only ones who have direct contact with the consumers, **it is the dealers' responsibility to make sure that his customers are properly instructed in safety matters relating to their installation.**

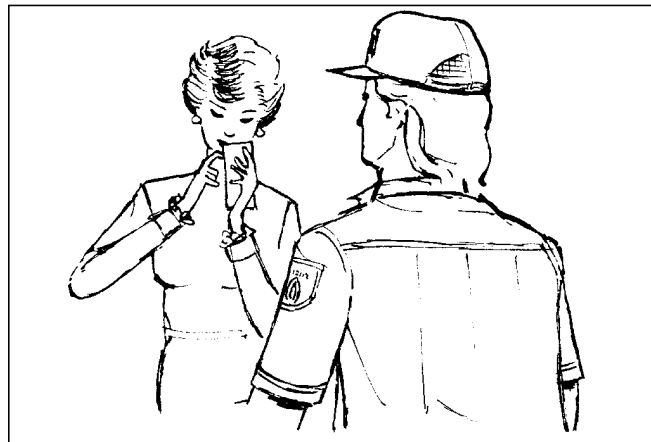

At the very minimum, it is desirable that these customers:

1. Know the odor of LP-Gas and what to do in case they smell gas. Use of the NPGA "Scratch 'n Sniff" leaflet could be productive.
2. Are instructed never to tamper with the system.
3. Know that when protective hoods are used to enclose regulators and/or valves, that these hoods must be closed, but not locked.
4. Know the location of the cylinder shut-off valve in emergencies.

General Warning

All RegO Products are mechanical devices that will eventually become inoperative due to wear, contaminants, corrosion and aging of components made of materials such as metal and rubber.

The environment and conditions of use will determine the safe service life of these products. Periodic inspection and maintenance are essential. Because RegO Products have a long and proven record of quality and service, LP-Gas dealers may forget the hazards that can occur because a cylinder valve is used beyond its safe service life. Life of a cylinder valve is determined by the environment in which it "lives". The LP-Gas dealers know better than anyone what this environment is. NOTE: There is a developing trend in state legislation and in proposed national legislation to make the owners of products responsible for replacing products before they reach the end of their safe useful life. LP-Gas dealers should be aware of legislation which could affect them.

Cylinder Valve Threads

Because of the many thread forms available on equipment used in the LP-Gas industry today, the maze of letters, numbers and symbols which make up various thread specifications becomes confusing. To help eliminate some of this confusion, a brief explanation of some of the more widely used thread specifications is shown below.

Inlet Connections

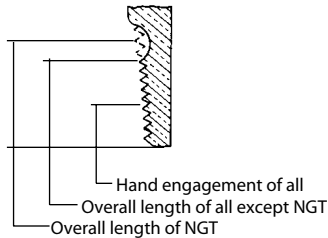

NGT and NPT Threads

The NGT (National Gas Taper) thread is the commonly used valve-to-cylinder connection. The male thread on the valve has about two more threads at the large end than the NPT in order to provide additional fresh threads if further tightening is necessary. Additionally, the standard $\frac{3}{4}$ " NGT valve inlet provides the greater tightness at the bottom of the valve by making the valve threads slightly straighter than the standard taper of $\frac{3}{4}$ " per foot in NPT connections. In all other respects NPT and NGT threads are similar.

Outlet Connections

CGA Outlets

The CGA (Compressed Gas Association) outlets are standard for use with various compressed gases. The relation of one of these outlets to another is fixed so as to minimize undesirable connections. They have been designed to prevent the interchange of connections which may result in a hazard.

$\frac{3}{8}$ "-18 NPT Thread Connection

This connection is also used for vapor or liquid withdrawal. It has a $\frac{3}{8}$ " diameter thread, and 18 threads per inch, National Pipe Taper Outlet form.

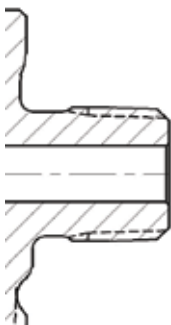

CGA 555

CGA 555 is the standard cylinder valve outlet connection for liquid withdrawal of butane and/or propane. Thread specification is $.903$ " - 14 NGO - LH - EXT, which means $.903$ " diameter thread, 14 threads per inch, National Gas Outlet form, left-hand external thread.

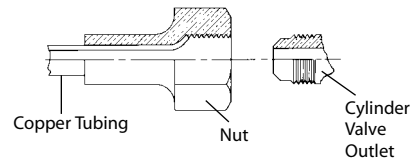
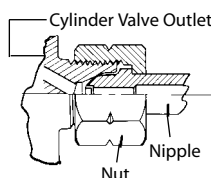

CGA 182, or SAE Flare

This connection ensures a leak-tight joining of copper tubing to brass parts without the need for brazing or silver soldering. The common size used on LP-Gas valves and fittings is $\frac{3}{8}$ " SAE (Society of Automotive Engineers) flare. Although this connection is referred to as a $\frac{3}{8}$ ", because $\frac{3}{8}$ " OD tubing is used, the thread actually measures $\frac{5}{8}$ ". The specifications are $.625 - 18 \text{ UNF} - 2A - \text{RH} - \text{EXT}$, which means $.625$ " diameter thread, 18 threads per inch, Unified Fine Series Class 2 Tolerances, right-hand, external thread.

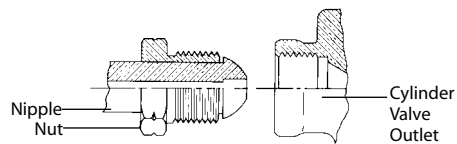

CGA 510 or POL

Most widely used in this industry, POL is the common name for the standard CGA 510 connection. Thread specification is $.885$ " - 14 NGO - LH - INT, meaning $.885$ " diameter thread, 14 threads per inch, National Gas Outlet form, left-hand internal thread. RegO POL outlet connections for LP-Gases conform to this standard.

LP-Gas Cylinder and Service Valves

General Information

The wide acceptance of RegO Cylinder Valves is based on their reliable performance as well as their reputation for engineering and manufacturing excellence.

Together with thorough testing, these efforts result in years of trouble-free service. RegO Cylinder Valves are listed by Underwriters' Laboratories and approved by the Bureau of Explosives for pressure relief valve operation, wherever applicable. See section on relief valves for important information.

Reliability

RegO Cylinder Valves are built with attention to each detail: Beginning with comprehensive inspection of forgings and machined parts, and ending with intense quality testing on each individual valve prior to shipment.

Every valve must pass a stringent and comprehensive underwater leakage test. Additionally, valves with pressure reliefs are tested for proper pressure and operation, including reseating to ensure proper opening and closing at required pressures. Those equipped with excess flow checks are tested for compliance with published closing specifications, and tested to ensure minimum leakage after closing.

Instructions for the Proper Use and Applications of RegO Cylinder Valves

1. Containers and pipe line should be cleaned thoroughly before valves are installed. Large particles of solid foreign matter can cut the seating surface of any resilient seat disc, causing the valve to leak. Care must be exercised in inserting valves into lines or containers to avoid damaging or exerting pressure against pressure relief valves and outlet connections. Use a minimum amount of a suitable luting compound on the cylinder valve threads only. Excess amounts of luting compound can foul the operating parts of the valves.

Heavy-Duty Valve Stem Seals

RegO Cylinder Valves utilize seat discs and stem seals which resist deterioration and provide the kind of reliable service required for LP-Gas utilization. Diaphragm or O-Ring stem seals are available. Valves with diaphragm stem seals are recognized for their heavy-duty body design and are suitable for use in cylinders up to 200 lbs. propane capacity.

O-Ring type stem seals are the most widely accepted in the industry. The simple, economical and long life design features a tapered and confined nylon seat disc which provides positive, hand-tight closings, and a faster filling cylinder valve.

Pressure Relief

RegO Valves have full-capacity "pop action" pressure reliefs with start to discharge settings starting at 375 PSIG.

A Valve for Every Need

RegO Cylinder Valves are available for all LP-Gas services; a wide choice for domestic, commercial, industrial, RV, motor fuel, and lift truck applications.

Valves are available with a combination of options such as pressure reliefs, liquid level gauges, and liquid withdrawal tubes. Also available for special applications are plumber's pot valves, tamper resistant valves for field service, and dual valves for simultaneous liquid and vapor service.

2. Do not use excessive force in opening or closing the valves. The seat disc and diaphragm materials permit the valves to be opened and closed easily by hand. Never use a wrench on wheel handle valves.
3. When the design of the piping installation allows liquid to be locked between two valves, a hydrostatic relief valve must be installed in the line between the two valves. The pressures which can develop due to temperature increase in a liquid full line are tremendous and can cause rupture of the line or damage to the valves.
4. The valves are designed to withstand normal atmospheric temperatures. They should not, however, be subjected to abnormally high temperatures.

Design Features of RegO Cylinder Valves

Valve Stems On 901, 9101, 9102 and 9103 Valves

Are machined with a double lead thread for quick opening and closing as well as high lift.

Forged Brass Body

Pressure Relief
Provides quick discharge of excess pressure. Relief seat disc is special resilient composition rubber.

Tapered Seat Openings On 9101, 9102 and 9103 Valves

Permit increased flow rates resulting in faster charging.

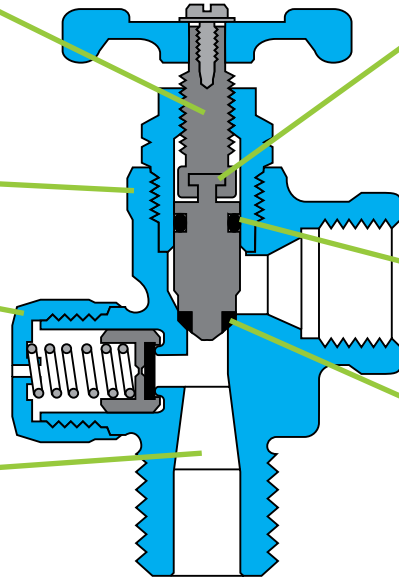

Back Seat On 901, 9101, 9102 and 9103 Valves

Is metal-to-metal seating to provide added protection against leakage while the valve is open. Back seat the valve while in operation.

O-Rings

For positive leak-proof seals under temperature and pressure variations.

Seat Disc

Is a tapered nylon in a fully confined seat to ensure easy, leak-free, positive shutoffs. Seat disc also provides a separate swivel action to minimize scoring by impurities.

Heavy-Duty Cylinder Valves for Vapor Withdrawal

9103 Series

Application

This heavy duty cylinder valve is designed for vapor withdrawal of DOT cylinders up to 100 lbs. propane capacity. It is used in domestic hookups and industrial commercial installations.

Features

- Equipped with a fast filling throat and high lift, o-ring stem seal design.
- Utilizes a nylon tapered seat design for positive closing.
- Available with a fixed liquid level gauge.
- Self-tapping screw secures handwheel to stem and reduces possibility of handwheel vibrating loose while in transit.

Materials

Body Forged Brass
 Handwheel..... Aluminum
 Stem Brass
 O-Rings Resilient Rubber
 Seat Disc Nylon
 Relief Spring Stainless Steel



9103D

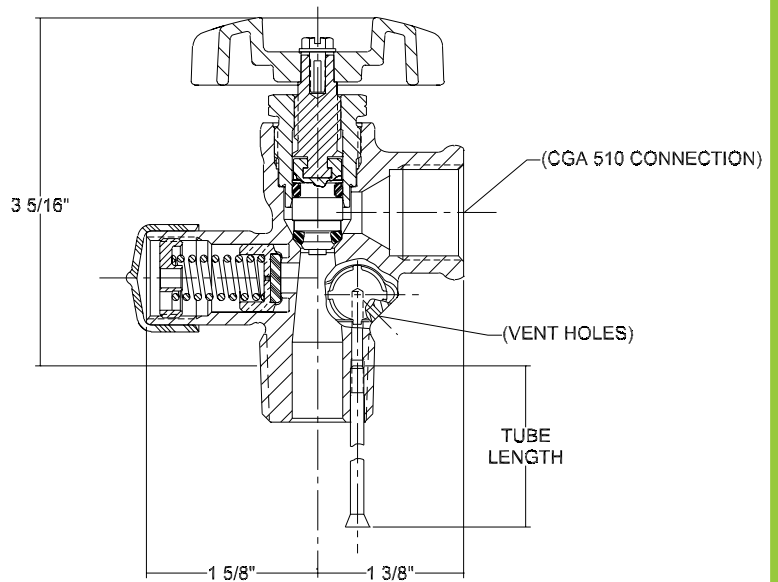

Ordering Information

Part Number	Container Connection	Service Connection	Fixed Liquid Level Vent Valve	Dip Tube Length w/ Deflector	Pressure Relief Valve Setting	For Use in Cylinders w/Propane Capacity Up To:	Approximate Filling Rate Liquid Flow, GPM				Accessories
							Pressure Drop Across Valves				
							10 PSIG	25 PSIG	50 PSIG	100 PSIG	POL Plug
*9103D10.6	¾" M NGT	F. POL (CGA 510)	Yes	10.6"	375 PSIG	100 lbs.	12.7	20.3	29.0	41.3	N970P
*9103D11.6				11.6"							

* 72 Orifice low emission version is also available.

Tamper-Resistant Cylinder Valve with Outlet Check for Vapor Withdrawal 9103T9F

Application

This valve is designed for vapor withdrawal from and protection of DOT cylinders up to 100 lbs. propane capacity. Ideal for cylinders used in the field by construction crews, utility repair men and plumbers.

Features

- Minimizes the risk of unauthorized persons withdrawing propane from cylinders not in service. It is necessary to install a male POL connection to open the outlet check to withdraw vapor from the valve.
- Ball type excess flow located in the valve inlet protects against excessive discharge if the cylinder is tipped or the hose ruptures. Closing flow is 200 SCFH at 100 PSIG.
- Removable POL outlet and check mechanism make field replacement of worn connections an easy process without removing the valve from the cylinder.
- Outlet seal plug on a heavy duty chain prevents dirt from entering POL when not in use.
- Nylon tapered seat design provides positive closure.

Materials

Body	Forged Brass
Handwheel.....	Aluminum Die Cast
Stem	Brass
O-Rings	Resilient Rubber
Seat Disc	Nylon
Relief Spring.....	Stainless Steel
Plug	Brass



9103T9F

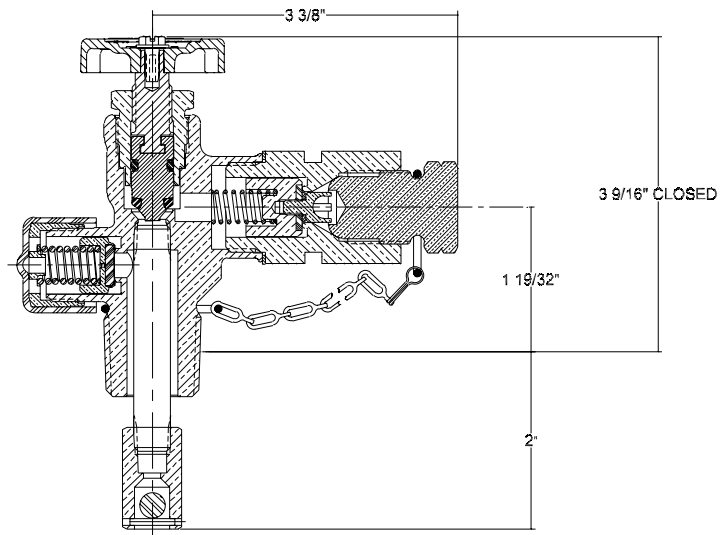

Ordering Information

Part Number	Container Connection	Service Connection	Fixed Liquid Level Vent Valve Style	Pressure Relief Valve Setting	For Use in Cylinders w/ Propane Capacity Up To:	Approximate Filling Rate Liquid Flow, GPM			
						Pressure Drop Across Valves			
						10 PSIG	25 PSIG	50 PSIG	100 PSIG
9103T9F	3/4" M. NGT	F. POL (CGA 510)	None	375 PSIG	100 lbs.	5.0	7.6	10.7	14.9

NOTE: These valves incorporate an excess flow valve. Refer to L-500/Section F, for complete information regarding selection, operation and testing of excess flow valves.

Cylinder Valve for RV and Small ASME System Vapor Withdrawal 9106CO

Application

Designed especially for vapor withdrawal service in small ASME containers with surface area up to 23.8 square feet. UL flow capacity is 645 SCFM/air.

Features

- One-piece relief valve is shielded from tampering and damage.
- Relief is forged as part of the body for extra strength.
- 312 PSIG Relief Valve setting.

Materials

Body Forged Brass
 Handwheel..... Aluminum Die Cast
 Stem Brass
 Seat Disc Nylon
 Relief Spring Stainless Steel



9106CO

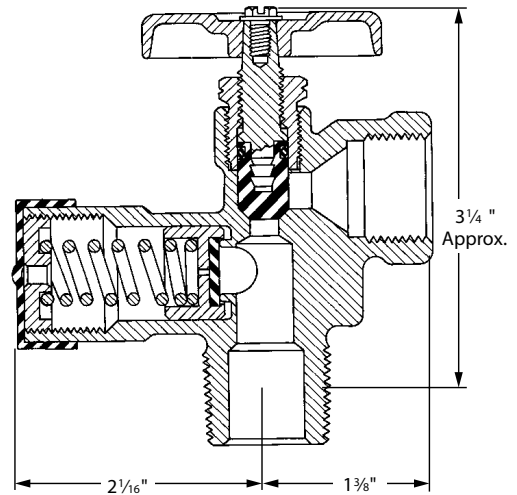

Ordering Information

Part Number	Container Connection	Service Connection	Fixed Liquid Level Vent Valve Style	Pressure Relief Valve Setting	For Use In Cylinders w/ Propane Capacity Up To	Flow Capacity SCFM/Air
9106CO	3/4" M. NGT	F. POL (CGA 510)	none	312 PSIG	ASME Tanks*	645

* Surface area up to 23.8 square feet.

Cylinder Valve for Liquid Withdrawal 9107K8A

Application

Equipped with excess flow valves and liquid withdrawal tubes, they are designed for liquid withdrawal of DOT cylinders up to 100 lbs. propane capacity. They are most often used with heavy BTU loads found in industrial uses.

Features

- O-ring stem seal design.
- Nylon tapered seat disc for positive closure.
- Self-tapping screw secures handwheel to stem and reduces possibility of handwheel vibrating loose while in transit.
- Features ball check excess flow valve.
- Furnished with 1/2" O.D. brass withdrawal tube with "T" dimension of 44".

Materials

Body Forged Brass
 Handwheel..... Aluminum Die Cast
 Seat Disc Nylon
 O-Rings Resilient Rubber
 Relief Spring..... Stainless Steel
 Stem Brass

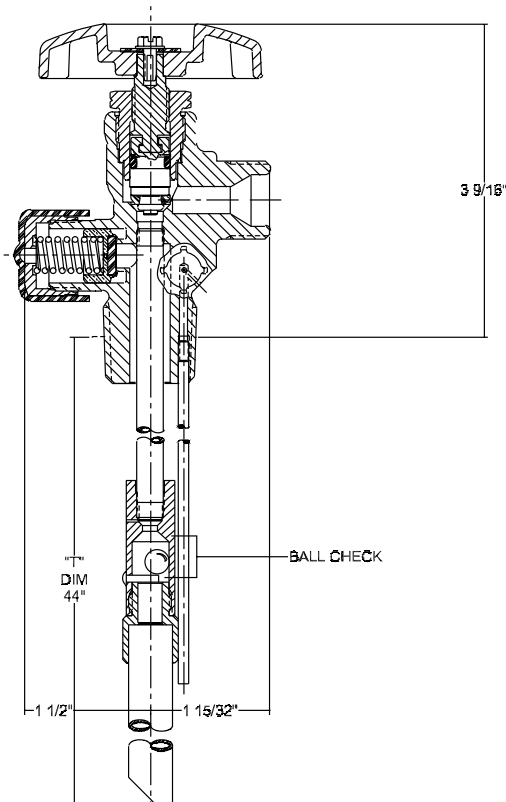

9107K8A



Ordering Information

Part Number	Container Connection	Service Connection	Fixed Liquid Level Vent Valve	Dip Tube Length	Liquid Withdrawal Tube Length
*9107K8A	3/4" M. NGT	CGA 555	Included	11.6"	44"

* 72 Orifice low emission version is also available.

Pressure Relief Valve Setting	For Use in Cylinders w/Propane Capacity Up To:	Approximate Filling Rate Liquid Flow, GPM				Closing Flow (L.P-Gas) *		
		Pressure Drop Across Valves				Vapor		Liquid
		10 PSIG	25 PSIG	50 PSIG	100 PSIG	25 PSIG Inlet	100 PSIG Inlet	
375 PSIG	100 lbs.	3.3	5.4	7.7	11.1	525 SCFH	1,000 SCFH	1.7 GPM

*Closing flows based on 3/8" O.D. withdrawal tube 44" long or less attached.

IMPORTANT: 1/4" O.D. pigtails or POL connections for 1/4" O.D. pigtails should not be used with these valves.

NOTES: To ensure proper functioning and maximum protection from excess flow valves, the cylinder valve should be fully opened and backseated when in use. These valves incorporate an excess flow valve. Refer to L-500 / Section F, for complete information regarding selection, operation and testing of excess flow valves.

Service Valves for ASME and DOT Containers or Vapor Fuel Line Applications 901C1, 9101C, 9101D, 9101R and PT9102 Series

Application

Designed for vapor withdrawal service on ASME and DOT containers or in fuel line applications. Since none of these valves have an integral pressure relief valve, they may only be used as an accessory valve on containers that have an independent pressure relief valve sufficient for that container's capacity.

Features

- O-Ring stem seal design provides positive seal.
- Metal-to-metal back seat provides added protection against leakage while the valve is open.
- Valves with fixed liquid level gauges permit operator to quickly determine when the maximum permitted filling level of the container is reached.
- 9101R Series with MultiBonnet allows quick and easy repair of bonnet.
- PT9102R Series **With the service valve closed the pressure test/Presto-Tap® port is isolated from the container.** This will allow a high pressure leak test to be conducted without disconnecting the pigtail from the service valve. For more information, see page C13 on this feature

Materials

Body Forged Brass
 Handwheel..... Aluminum Die Cast
 Stem Brass
 O-Rings Resilient Synthetic Rubber
 Seat Disc Nylon



PT9102



9101D



901C1

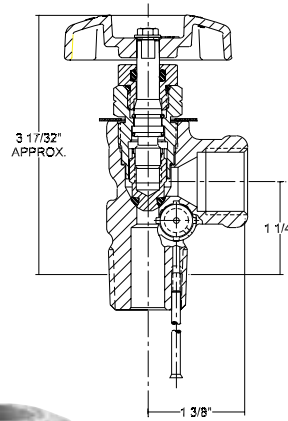
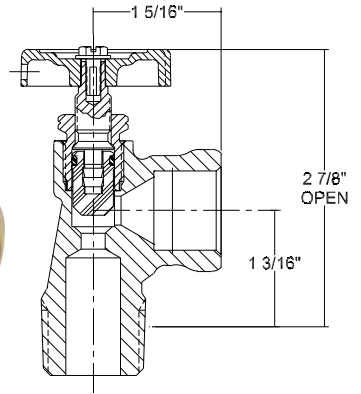

9101R1

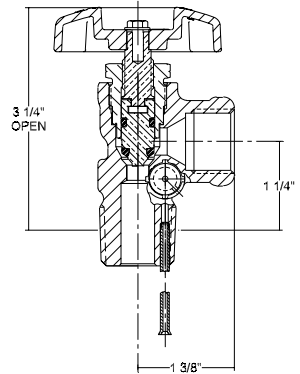

Ordering Information

Part Number	Bonnet Style	Container Connection	Service Connection	Fixed Liquid Level Vent Valve	Approximate Filling Rate Liquid Flow, GPM				Ready To Go™		
					Pressure Drop Across Valve						
					10 PSIG	25 PSIG	50 PSIG	100 PSIG			
901C1	Standard	3/4" M. NGT	F. POL CGA 510	No	5.3	8.2	10.8	14.2	NA		
9101C1				No	8.8	12.4	15.8	21.7			
*9101D11.1				Yes	8.6	12.7	16.3	22.3			
*9101D11.7				Yes	8.6	12.7	16.3	22.3			
9101R1	MultiBonnet			3/4" M. NGT	F. POL CGA 510	No	7.6	11.7	15.2	20.6	No
*9101R11.1						Yes					No
*9101R11.7						Yes					Plugged
9102D11.1						No					Yes
9102R11.7		Yes									
*PT9102R1		No									
*PT9102R11.1		Yes	Yes								
*PT9102R11.7	Yes	Yes									

* 72 Orifice low emission version is also available.

Note: Since these valves have no integral pressure relief valve, they can be used on any container with an independent relief device sufficient for that tank's capacity.

Service Valves for ASME Motor Fuel Containers 901C, 9101H, and 9101Y Series

Application

Designed specifically for vapor or liquid withdrawal service on ASME motor fuel containers. Since none of these valves have an integral pressure relief valve, they may only be used as an accessory valve on containers that have an independent pressure relief valve sufficient for that container's capacity.

The integral excess flow valve found in all these service valves helps prevent excessive product loss in the event of fuel line rupture.

When installed for liquid withdrawal, the 9101H6 has provisions for attachment of a liquid withdrawal tube. All other valves must be installed in containers that have provisions for a separate liquid withdrawal.

To ensure proper functioning and maximum protection from integral excess flow valves, these service valves should be fully opened and backseated when in use.

Features

- Incorporates integral excess flow valve and shut-off valve in one unit.
- Double lead thread provides faster opening and closing.
- O-Ring stem seal design provides positive seal.
- Tapered and confined seat disc provides positive shut off.
- Metal-to-metal back seat provides added protection against leakage while the valve is open.
- 9101H6 equipped with a 1/4" NPT internal thread for the addition of a liquid withdrawal tube.
- 9101Y Series features a 60° angled outlet connection to facilitate easier and simpler fuel line make-up.

Materials

Body Forged Brass
 Handwheel..... Aluminum Die Cast
 Stem Brass
 O-Rings Resilient Synthetic Rubber
 Seat Disc Nylon

Ordering Information

Part Number	Container Connection	Service Connection	Liquid Withdrawal Connection	Closing Flow (LP-Gas)		
				Vapor		Liquid GPM
				25 PSIG Inlet (SCFH)	100 PSIG Inlet (SCFH)	
901C3	3/4" M. NGT	F. POL CGA 510	None	350***	605***	1.5***
901C5				550***	1050***	2.6***
9101H3		3/8" SAE Flare		430**	800**	1.5**
9101H5*				765**	1300**	3.6**
9101H6*		1/4" NPT		550****	1050****	2.6****
9101Y5H*		60° Angle 3/8" SAE Flare		None	765**	1300**

* Heavy-duty models
 ** Based on 3/8" O.D. pigtail, 20" long or less, connected to valve outlet. For greater lengths, the pigtail must have a larger O.D.
 *** Same as (**). In addition, 1/4" O.D. pigtails or POL connections for 1/4" O.D. should not be used with this valve.
 **** Based on 3/8" O.D. pigtail; 20" long or less, connected to valve outlet. Also based on 1/4" pipe size dip tube, 42" long or less, attached to special inlet connection. For longer pigtail lengths, the diameter of the pigtail must be increased.
 NOTE: These valves incorporate an excess flow valve. Refer to L-500/Section F, for complete information regarding selection, operation and testing of excess flow valves.



901C5

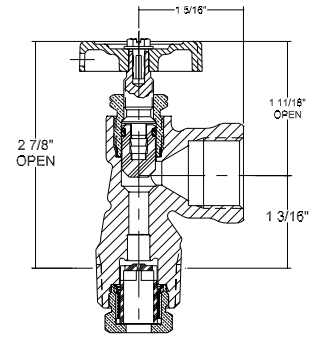

9101H5

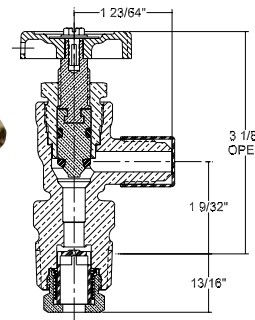

9101H6

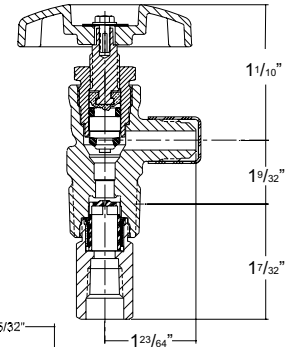

9101Y5H

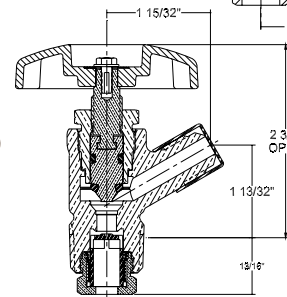

Service Valves for DOT Fork Lift Containers 9101P5 and 9101P6 Series

Application

Designed specifically for vapor or liquid withdrawal service on DOT fork lift containers. Valves with 1.5 GPM closing flow are for use in small and medium size lift truck applications, while those with 2.6 GPM closing flow are for large lift trucks. Since none of these valves have an integral pressure relief valve, they may only be used as an accessory valve on containers that have an independent pressure relief valve sufficient for that cylinder's capacity.

The integral excess flow valve found in all these service valves helps prevent excessive product loss in the event of fuel line rupture.

When installed for liquid withdrawal, the 9101P6 Series has provisions for attachment of a liquid withdrawal tube. The 9101P5 Series must be installed in containers that have provisions for a separate liquid withdrawal.

To ensure proper functioning and maximum protection for integral excess flow valves, these service valves should be fully opened and backseated when in use.

Features

- Incorporates integral excess check valve and shut-off valve in one unit.
- Special 1.5 GPM closing flow on select valves provided especially for lift trucks and equipment with smaller engines.
- Double lead stem thread provides faster opening and closing.
- O-Ring stem seal design provides positive seal.
- Tapered and confined seat disc provides positive shut-off.
- Metal-to-metal back seat provides added protection against leakage while the valve is open.
- 9101P6 Series equipped with a 1/4" NPT internal thread for the addition of a liquid withdrawal tube.

Materials

Body Forged Brass
 Handwheel..... Aluminum Die Cast
 Stem Brass
 O-Rings Resilient Synthetic Rubber
 Seat Disc Nylon

Ordering Information

Part Number	Container Connection	Service Connection	Liquid Withdrawal Connection	Closing Flow (LP-Gas)			Approximate Filling Rate Liquid Flow, GPM				Accessories		
				Vapor		Liquid (GPM)	Pressure Drop Across Valve				ACME Check Connectors		
				25 PSIG Inlet (SCFH)	100 PSIG Inlet (SCFH)		10 PSIG	25 PSIG	50 PSIG	100 PSIG	Male	Female	Cap
9101P5	1/4" M. NGT	3/8" M. NPT	None	430	900	1.5	5.0	7.6	10.7	14.9	7141M	7141F	7141M-40 or 7141FP
9101P5H				550	1050	2.6							
9101P6			1/4" NPT	430	900	1.5	4.5	7.2	10.3	14.8			
9101P6H				550	1050	2.6							

Note: These valves incorporate an excess flow valve. Refer to L-500/Section F, for complete information regarding selection, operation and testing of excess flow valves.



9101P5
9101P5H

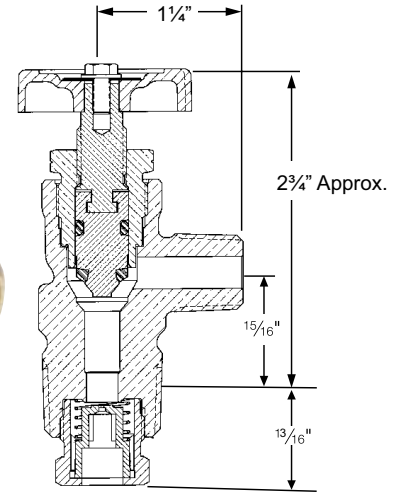

9101P6
9101P6H

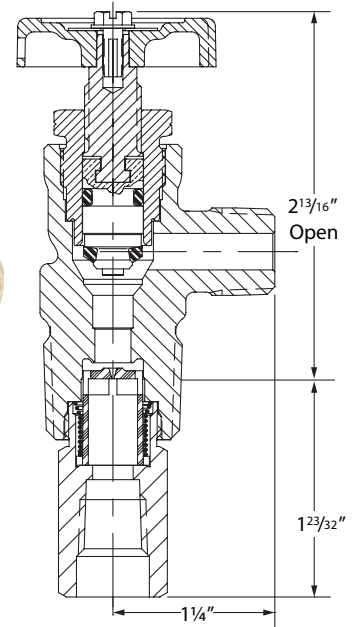

Cylinder Valve for Propylene Service 9104PT and 9104PPA

Application

Designed for vapor withdrawal from and protection of DOT cylinders up to 100 lbs. propylene capacity with pressure ratings such as 4B-260, 4BA-260, and 4BW-260 cylinders.



Features

- Nylon tapered seat designed for positive closing.
- Relief is forged as part of the body for extra strength.
- Available with Fixed Liquid Level Gauge.
- 435 PSIG Relief Valve Setting.
- Meets TB27 requirements.
- $\frac{3}{32}$ " Markings.

Materials

Body	Forged Brass
Handwheel.....	Aluminum
Stem	Brass
Seat Disc.....	Viton
Relief Spring.....	Stainless Steel
Relief Valve Setting	435 PSIG TB27



9104PT



9104PPA

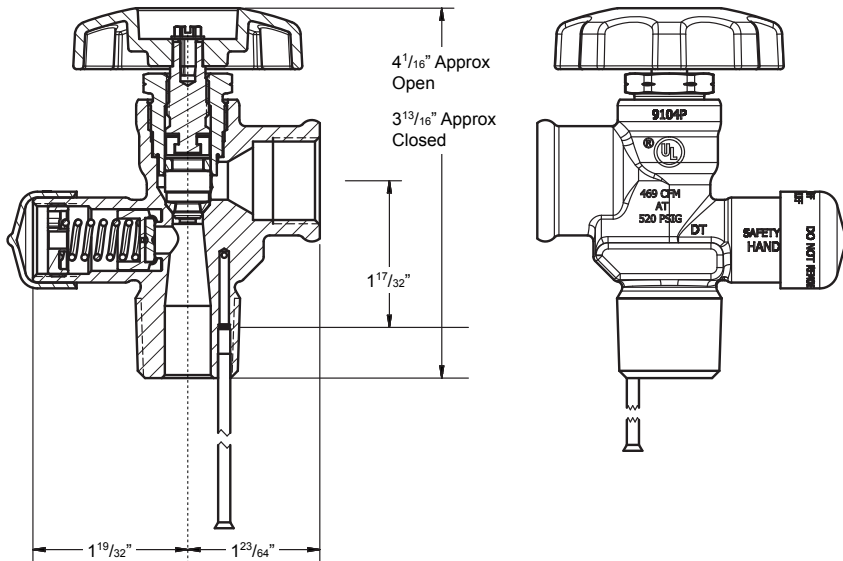

Ordering Information

Part Number	Container Connection	Service Connection	Fixed Liquid Level Vent Valve Style	Dip Tube Length*	Pressure Relief Valve Setting	For use in Cylinders w/ Propylene Capacity up to:
9104PPA	1/4" M.NPT	F.POL - (CGA 510)	N/A	N/A	435 PSIG	100lbs
*9104PT10.1			Knurled	10.0"		
*9104PT10.7				10.7"		

* Valve can be ordered with other dip tube lengths. Specify required length when ordering. X = diptube size

“Dual” Cylinder Valve for Simultaneous Liquid and Vapor Withdrawal 8556

Application

This dual cylinder valve was designed especially for industrial uses. It increases the cylinder’s flexibility by permitting DOT cylinders up to 100 lbs. propane capacity to be used interchangeably or simultaneously for either liquid or vapor withdrawal.



Features

- Two separate flow channels in the body permit vapor and/or liquid withdrawal alternately, or simultaneously.
- Outlet connections have two different fittings.
- Handwheels are equipped with appropriate “liquid” or “vapor” identification labels.
- Furnished with a 3/8” O.D. stainless steel liquid withdrawal tube with a “T” dimension of 44”.

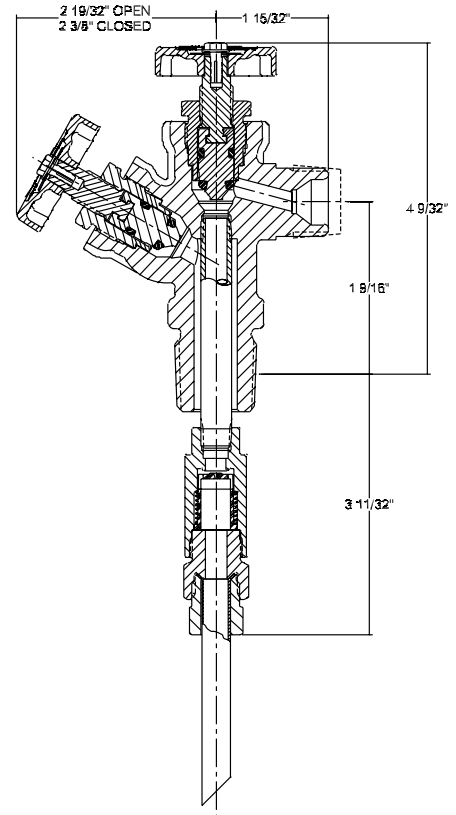
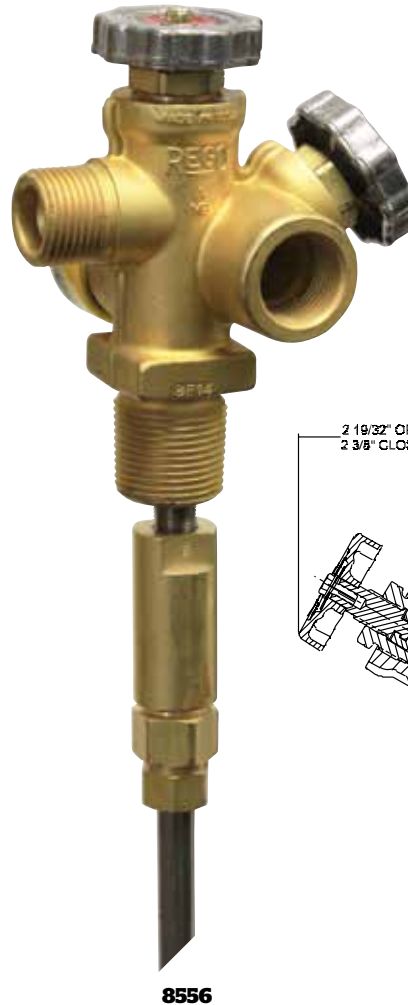

Materials

Body	Forged Brass
Handwheel.....	Aluminum Die Cast
Stem	Brass
Seat Disc	Nylon
O-Rings	Resilient Rubber
Relief Spring	Stainless Steel



Ordering Information

Part Number	Container Connection	Service Connection		Fixed Liquid Level Vent Valve Style	Liquid Withdrawal Tube Length
		Vapor	Liquid		
8556	3/4" M. NGT	F. POL (CGA 510)	CGA 555	None	44"

Pressure Relief Valve Setting	For Use in Cylinders w/Propane Capacity Up To:	Approximate Filling Rate Liquid Flow, GPM				Liquid Closing Flow* (LP-Gas)
		Pressure Drop Across Valves				
		10 PSIG	25 PSIG	50 PSIG	100 PSIG	
375 PSIG	100 lbs.	6.6	10.0	14.5	21.0	2.3 GPM

* To ensure proper functioning and maximum protection from integral excess flow valves, the cylinder valve should be fully opened and backseated when in use.
NOTE: These valves incorporate an excess flow valve. Refer to L-500/Section F, for complete information regarding selection, operation and testing of excess flow valves.

Adhesive Warning Labels 901-400 and 903-400

These adhesive warning labels are intended for application as close as possible to the cylinder valve and/or service valve.

The basic information contained on the label is intended for the benefit of the user of the valves and is not intended to be an "all-inclusive" product warning.

These labels are printed on a heavy duty material with pressure sensitive adhesive backing. The ultra-violet ink stands up well when exposed to the environment.

Part Number	
901-400	Adhesive Label Primarily for Fork Lift Cylinders
903-400	Adhesive Label Primarily for Small DOT Cylinders
903-500	Adhesive Label Primarily for Cylinder and Service Valves

DANGER	LP-GAS IS EXTREMELY FLAMMABLE AND EXPLOSIVE KEEP CYLINDER OUT OF THE REACH OF CHILDREN	WARNING
<p>AVOID SERIOUS INJURY AND PROPERTY DAMAGE. IF YOU SEE, SMELL, OR HEAR THIS HISS OF ESCAPING GAS... IMMEDIATELY GET AWAY FROM THIS CYLINDER. CALL YOUR LOCAL FIRE DEPARTMENT. DO NOT ATTEMPT TO REPAIR. DO NOT USE OR STORE IN BUILDING OR ENCLOSED AREA. FOR OUTDOOR USE ONLY.</p> <p>This cylinder is filled with highly flammable LP-Gas under pressure. A serious fire or explosion can result from leaks and misuse or misreading of the cylinder and valve valves. Do not move, hold or fill the cylinder by any of its valves. Do not expose to fire or temperatures above 120°F (49°C). Do not use if the Pressure Relief Valve can expel a large jet of LP-Gas into the air if the cylinder is (1) exposed to high temperatures - over 120°F (49°C) or (2) overfilled and exposed to a temperature higher than the temperature at the time it was filled. Do not attempt to fill this cylinder yourself. Do not tamper with it or attempt repairs.</p> <p>Only trained LP-Gas Dealer personnel should be permitted to fill this cylinder and to repair or replace its valve. Each time the cylinder is filled, the entire Cylinder Valve must be checked for leaks (with a leak detection solution... leaks cause bubbles to grow). The Shut-Off Valve and Fixed Liquid Level Gauge (if incorporated) must be checked for proper operation. The Pressure Relief Valve must be checked to ensure that it is completely unobstructed and that it has no physical damage. CAUTION: eye protection must be worn when working with "leak detection solution" bubbles to grow.</p> <p>When not in use, keep the service shut-off valve closed. When in use, keep the service valve fully open. Keep this equipment out of the reach of children.</p> <p>The container must be used only in compliance with all applicable laws and regulations, including National Fire Protection Association Publication #58, which is the law in many states. A copy of this publication may be obtained by writing NFPA, Batterymarch Park, Quincy, MA 02269.</p>		
<p>DO NOT REMOVE, DEFACE OR OBLITERATE THIS LABEL. DO NOT FILL THIS CONTAINER UNLESS THIS LABEL IS READABLE.</p> <p>ADDITIONAL SAFETY INFORMATION IS AVAILABLE FROM  REGO <small>Elon, NC 27244 U.S.A. • Phone (336) 449-7707 • Fax (336) 449-6594</small></p> <p>Printed in U.S.A. 09-0414-0386 Warning 901-400</p>		

901-400

DANGER!	LP-GAS IS EXTREMELY FLAMMABLE AND EXPLOSIVE KEEP CYLINDER OUT OF THE REACH OF CHILDREN	WARNING!
<p>AVOID SERIOUS INJURY AND PROPERTY DAMAGE. IF YOU SEE, SMELL, OR HEAR THIS HISS OF ESCAPING GAS... IMMEDIATELY GET AWAY FROM THIS CYLINDER. CALL YOUR LOCAL FIRE DEPARTMENT. DO NOT ATTEMPT TO REPAIR. DO NOT USE OR STORE IN BUILDING OR ENCLOSED AREA. FOR OUTDOOR USE ONLY.</p> <p>This cylinder contains highly flammable LP-Gas under pressure. A serious fire or explosion can result from leaks and misuse or misreading of the cylinder and its valves. Do not carry, hold or fill the cylinder by its valve. Do not expose to fire or temperatures above 120°F (49°C).</p> <p>The Cylinder Valve incorporates a Shut-Off Valve and Pressure Relief Valve. The Pressure Relief Valve can expel a large jet of LP-Gas into the air if the cylinder is (1) exposed to high temperatures - over 120°F (49°C) or (2) overfilled and exposed to a temperature higher than the temperature at the time it was filled. Never attempt to fill this cylinder yourself. Do not tamper with it or attempt repairs.</p> <p>Only trained LP-Gas Dealer personnel should be permitted to fill this cylinder and to repair or replace its valve. Each time the cylinder is filled, the entire Cylinder Valve must be checked for leaks (with a leak detection solution... leaks cause bubbles to grow). The Shut-Off Valve and Fixed Liquid Level Gauge (if incorporated) must be checked for proper operation. The Pressure Relief Valve must be checked to ensure that it is completely unobstructed and that it has no physical damage. CAUTION: eye protection must be worn when working with "leak detection solution" bubbles to grow.</p> <p>When not in use, keep the service shut-off valve closed. When in use, keep the service valve fully open. Keep this equipment out of the reach of children.</p> <p>The container must be used only in compliance with all applicable laws and regulations, including National Fire Protection Association Publication #58, which is the law in many states. A copy of this publication may be obtained by writing NFPA, Batterymarch Park, Quincy, MA 02269.</p>		
<p>DO NOT REMOVE, DEFACE OR OBLITERATE THIS LABEL. DO NOT FILL THIS CYLINDER UNLESS THIS LABEL IS READABLE!</p> <p>ADDITIONAL SAFETY INFORMATION IS AVAILABLE FROM  REGO <small>Elon, NC 27244 U.S.A. • Phone (336) 449-7707 • Fax (336) 449-6594</small></p> <p>Printed in U.S.A. 09-0414-0384 Warning 903-400</p>		

903-400

The following warning information, Part Number 903-500, is included with each shipment of cylinder valves and service valves to the first purchaser of the product from the factory.

This information is intended to be forwarded throughout the product distribution chain. Additional copies are available from RegO and Authorized Product Distributors.

DANGER	READ THIS FIRST	WARNING
<p>LP-GAS IS EXTREMELY FLAMMABLE AND EXPLOSIVE</p> <p>AVOID SERIOUS INJURY AND PROPERTY DAMAGE. IF YOU SEE, SMELL OR HEAR ESCAPING GAS...EVACUATE AREA IMMEDIATELY! CALL YOUR LOCAL FIRE DEPARTMENT. DO NOT ATTEMPT TO REPAIR. DO NOT STORE IN BUILDING OR ENCLOSED AREA. DO NOT USE ON HOT AIR BALLOONS OR AIRCRAFT.</p> <p>Make sure you are thoroughly trained before you attempt any valve installation, maintenance or repair. Improper conditions or procedures can cause accidents resulting in property damage and personal injury.</p> <p>Become thoroughly familiar with NFPA Safety Pamphlet 308 "LP-Gas Regulator and Valve Inspections & Maintenance" and RegO Safety Warnings "LP-Gas Cylinder Valves", "LP-Gas Excess Flow Valves", and "LP-Gas Filler and Hose End Filling Valves" found in the cylinder valve, excess flow valve, and filler valve sections of the L-500 & L-102 Catalogs. Follow their recommendations.</p> <p>Know and understand NFPA Pamphlet 58 "Liquefied Petroleum Gas Code", which is the law in many states. This publication is available from NFPA, Batterymarch Park, Quincy, MA 02269. Following its requirements is essential in the safe use of LP-Gas. Section 4.4 states: "Persons who transfer liquid LP-Gas, who are employed to transport LP-Gas, or whose primary duties fall within the scope of this code shall be trained in proper handling procedures. Refresher training shall be provided at least every three years and shall be documented."</p> <p>Make sure this valve is the proper one for this installation. Avoid misusing LP-Gas equipment.</p> <p>Apply thread joint compound compatible with LP-Gas on valve external threads only. Make sure compound never comes into contact with other parts of the valve.</p> <p>Install valves by applying force to wrenching flats only.</p> <p>Tighten pipe threads approximately 1 to 1½ turns beyond the hand-tight insertion point using a wrench which avoids damage to other valve parts.</p> <p>Check for damage and proper operation after valve installation. Check that the valve is clean and free of foreign material.</p> <p>Check container-valve connection with a non-corrosive leak detection solution before filling with LP-Gas.</p> <p>Purge container before filling with LP-Gas (refer to the RegO LP-Gas Serviceman's Manual for recommended procedure).</p> <p>Test excess flow check valve for proper operation before placing into service. See NFPA Bulletin 113 for recommended procedure.</p> <p>Check outlet connection make-up for leaks with a non-corrosive leak detection solution when placing into service.</p> <p>RegO Filler Valves: To prevent damage to the internal checks when it is necessary to utilize an unloading adapter, use ONLY RegO 3113A, 3120 and 3121 Unloading Adapters with RegO Filler Valves. Carefully follow the instructions supplied with these unloading adapters.</p> <p>If container is not being placed into service at the present time, insert plug or cap onto the outlet connection.</p> <p>In selecting a label for posting at the installation site, consider RegO part number 901-400 or 903-400 along with your own, NFPA's and others.</p> <p>Remember to instruct the owner/user/customer in safety matters concerning LP-Gas and this equipment. See RegO Safety Warnings "LP-Gas Cylinder Valves", "LP-Gas Excess Flow Valves", and "LP-Gas Filler and Hose End Filling Valves" found in the cylinder valve, excess flow valve, and filler valve sections of the L-500 & L-102 Catalogs.</p>		
<p>RegO requests that this information be forwarded to your customers. Additional copies are available from RegO and your authorized RegO Distributor.</p> <p> REGO <small>Elon, NC 27244 U.S.A. • Phone (336) 449-7707 • Fax (336) 449-6594 • www.regoproducts.com</small></p> <p>Printed in USA 09A-0910-0686 Part number 903-500</p> <p>903-500</p>		